

# MSM63184A

**4-Bit Microcontroller with Built-in 640-Dot Matrix LCD Drivers, Operating at 0.9 V (Min.)**

## GENERAL DESCRIPTION

The MSM63184A is a CMOS 4-bit microcontroller with built-in 640-dot matrix LCD drivers and operates at 0.9 V (min.). The MSM63184A is suitable for applications such as games, toys, watches, etc. which are provided with an LCD display.

The MSM63184A is an M6318x series mask ROM-version product of OLMS-63K family, which employs Oki's original CPU core nX-4/250.

The MSM63P180 is the one-time-programmable ROM version of MSM63188A, having one-time PROM (OTP) as internal program memory.

The MSM63P180 is used to evaluate the software development.

## FEATURES

- Rich instruction set
  - 439 instructions
  - Transfer, rotate, increment/decrement, arithmetic operations, comparison, logic operations, mask operations, bit operations, ROM table reference, external memory transfer, stack operations, flag operations, branch, conditional branch, call/return, control.
- Rich selection of addressing modes
  - Indirect addressing of four data memory types, with current bank register, extra bank register, HL register and XY register.
  - Data memory bank internal direct addressing mode.
- Processing speed
  - Two clocks per machine cycle, with most instructions executed in one machine cycle.
  - Minimum instruction execution time : 61  $\mu$ s (@ 32.768 kHz system clock)  
1  $\mu$ s (@ 2MHz system clock)
- Clock generation circuit
  - Low-speed clock : Crystal oscillator (32.768 kHz)
  - High-speed clock : Select ceramic oscillator (2 MHz Max.) or RC oscillator (1 MHz Max.) using software.
- Program memory space
  - 8K words
  - Basic instruction length is 16 bits/word
- Data memory space
  - 640 nibbles
- External data memory space
  - Expandable beyond 64 Kbytes by using I/O port.
- Stack level
  - Call stack level : 8 levels
  - Register stack level : 16 levels

- I/O ports
  - Input ports : Selectable as input with pull-up resistance/input with pull-down resistance/high-impedance input
  - Output ports : Selectable as P-channel open drain output/N-channel open drain output/CMOS output/high-impedance output
  - Input-output ports: Selectable as input with pull-up resistance/input with pull-down resistance/high-impedance input  
Selectable as P-channel open drain output/N-channel open drain output/CMOS output/high-impedance output

Can be interfaced with external peripherals that use a different power supply than this device uses.

Number of ports

  - Input port : 2 ports × 4 bits
  - Output port : 4 ports × 4 bits
  - Input-output port : 5 ports × 4 bits
- Buzzer function
  - Buzzer output : 0.946 to 5.461 kHz (adjustable in 15 steps)
  - Buzzer output modes : Intermittent sound 1, 2; simple sound; continuous sound
- LCD driver
  - Number of segments : 640 Max. (40 SEG × 16 COM)
  - 1/1 to 1/16 duty
  - 1/4 or 1/5 bias (regulator built-in)
  - Selectable as all-on mode/all-off mode/power down mode/normal display mode
  - Adjustable contrast
- Reset function
  - Reset through RESET pin
  - Power-on reset
  - Reset by low-speed oscillation halt
- Battery check
  - Low-voltage supply check
  - Criterion voltage : Can be selected as 1.05 ±0.10 V, 1.30 ±0.15 V, 2.20 ±0.20 V or 2.80 ±0.30 V
- Power supply backup
  - Backup circuit (voltage multiplier) enables operation at 0.9 V minimum
- Timers and counter
  - Watchdog timer × 1
    - Overflows in 2 sec.
  - 100 Hz timer × 1
    - Measurable in steps of 1/100 sec.
  - 15-bit time base counter × 1
    - 1, 2, 4, 8, 16, 32, 64 and 128 Hz signals can be read
- Shift register
  - Shift clock : 1x or 1/2x system clock; external clock
  - Data length : 8 bits
- Interrupt sources
  - External interrupt : 3
  - Internal interrupt : 7 (watchdog timer interrupt is a nonmaskable interrupt)

- Operating voltage
  - When backup used
    - : 0.9 to 2.7 V  
(Low-speed clock operating)
    - 1.2 to 2.7 V  
(Operating frequency: 300 to 500 kHz)
    - 1.5 to 2.7 V  
(Operating frequency: 200 kHz to 1 MHz)
  - When backup not used
    - : 1.8 to 5.5 V  
(Operating frequency: 300 to 500 kHz)
    - 2.2 to 5.5 V  
(Operating frequency: 300 kHz to 1 MHz)
    - 2.7 to 5.5 V  
(Operating frequency: 200 kHz to 2 MHz)
- Package:
  - 128-pin plastic QFP (QFP128-P-1420-0.50-K) : (Product name: MSM63184A-xxxGS-K)
  - Chip (123 pads) : (Product name: MSM63184A-xxx)

xxx indicates a code number.

**BLOCK DIAGRAM**

An asterisk (\*) indicates the port secondary function.    indicates that the power is supplied to the circuits corresponding to the signal names inside    from  $V_{DDI}$  (power supply for interface).

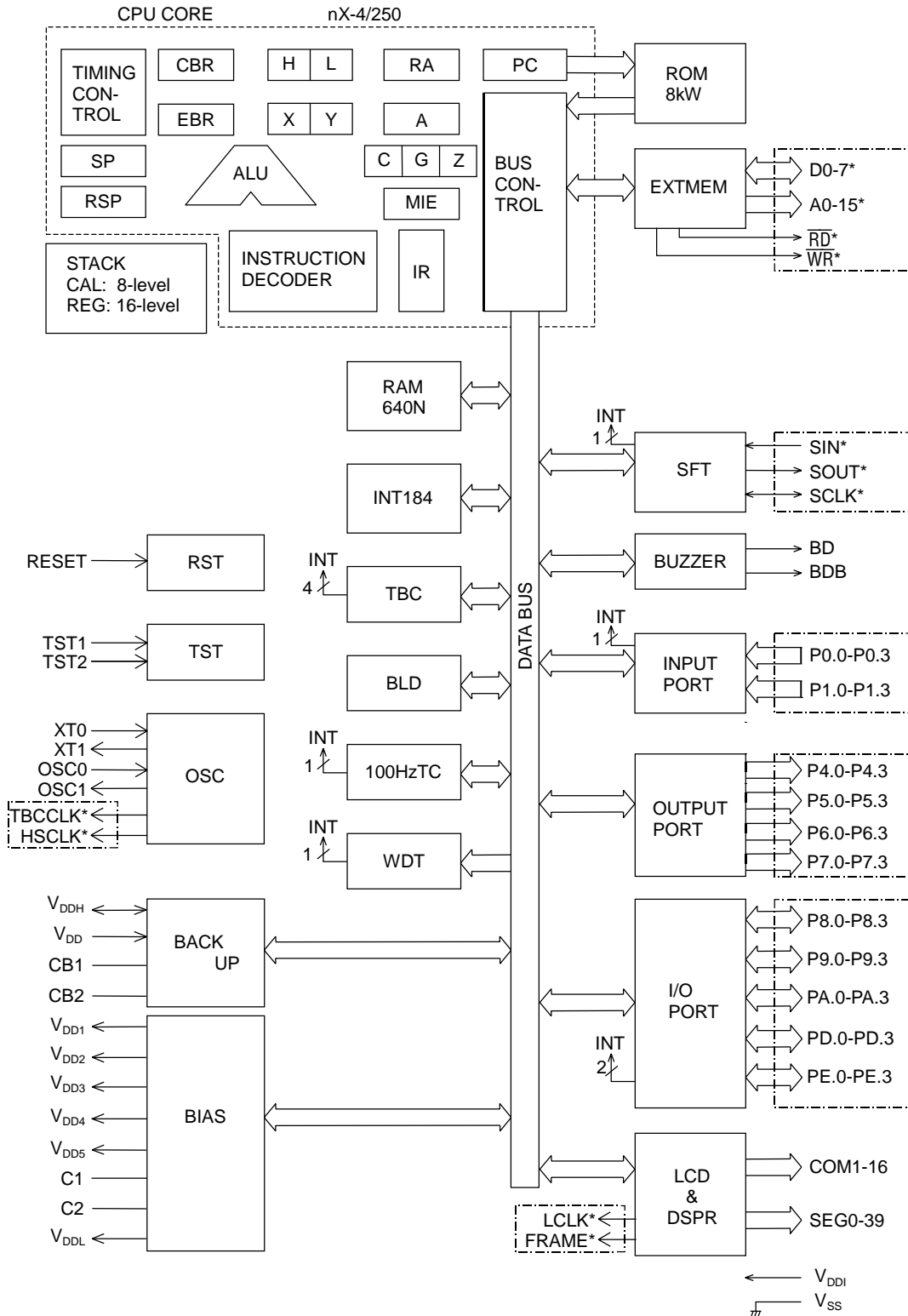

**PIN CONFIGURATION (TOP VIEW)**

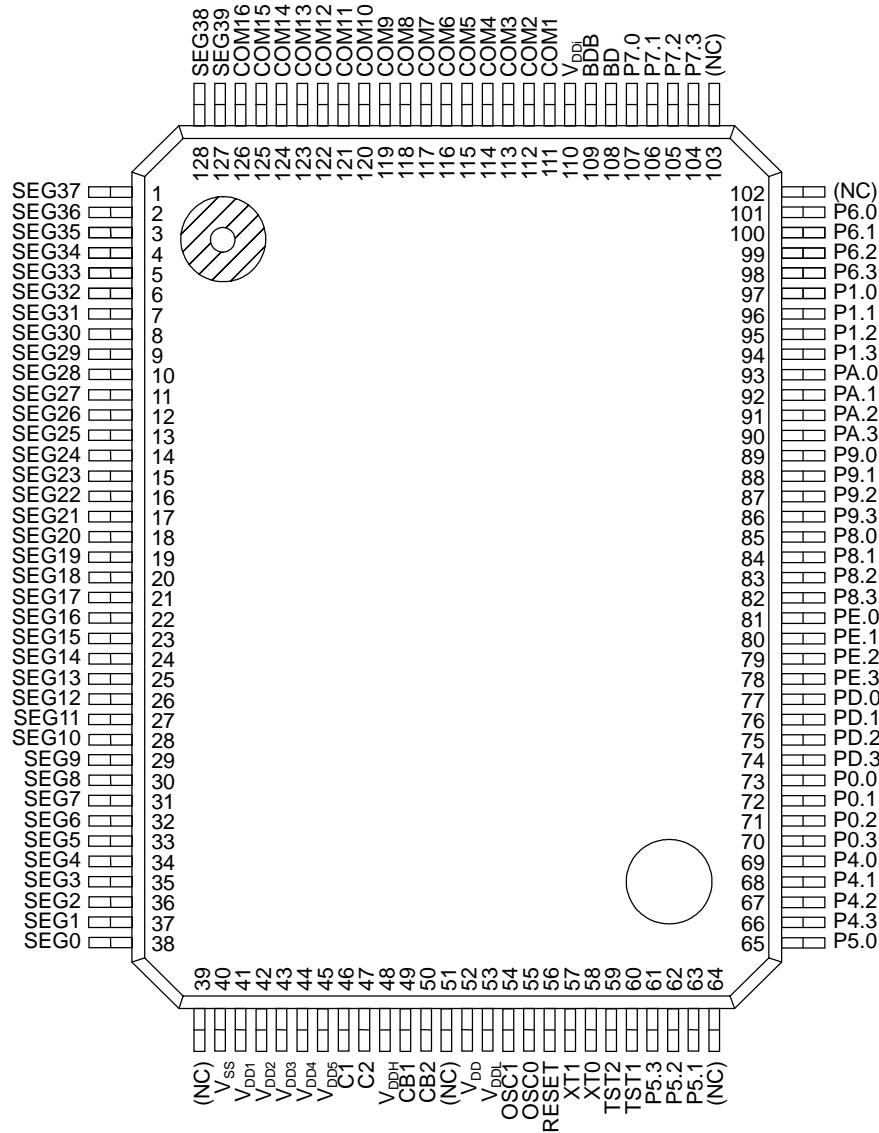

**128-Pin Plastic QFP**

Note: Pins marked as (NC) are no-connection pins which are left open.

**PAD CONFIGURATION**

**Pad Layout**

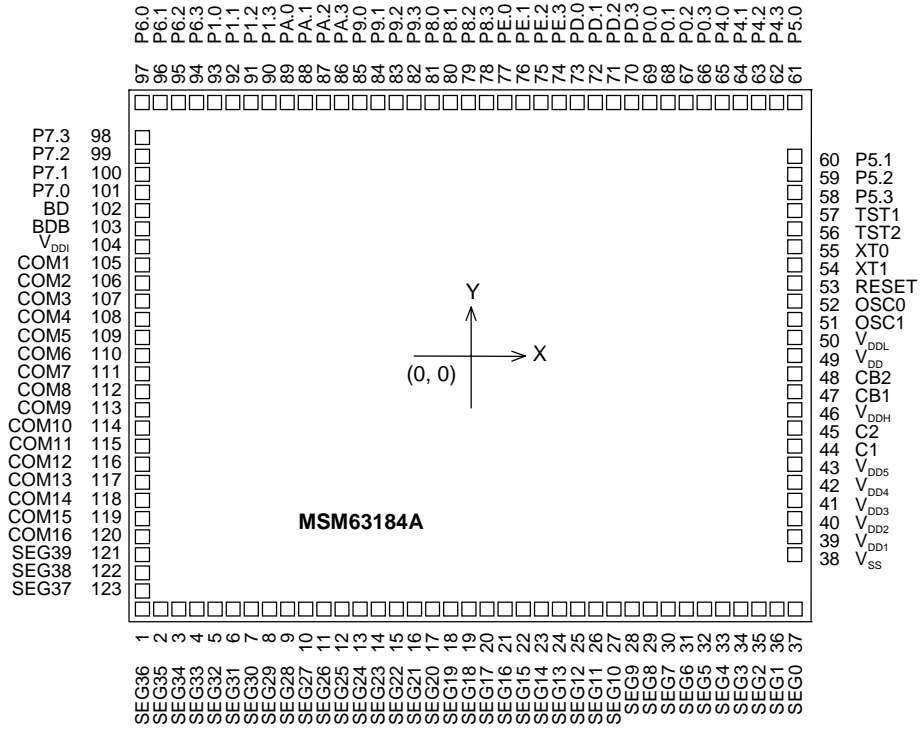

Chip Size : 5.35 mm × 4.66 mm  
 Chip Thickness : 350 μm (typ.)  
 Coordinate Origin : Chip center  
 Pad Hole Size : 100 μm × 100 μm  
 Pad Size : 110 μm × 110 μm  
 Minimum Pad Pitch: 140 μm

Note: The chip substrate voltage is V<sub>SS</sub>.

## Pad Coordinates

Pad No.	Pad Name	X ( $\mu\text{m}$ )	Y ( $\mu\text{m}$ )	Pad No.	Pad Name	X ( $\mu\text{m}$ )	Y ( $\mu\text{m}$ )	Pad No.	Pad Name	X ( $\mu\text{m}$ )	Y ( $\mu\text{m}$ )
1	SEG36	-2520	-2135	42	V <sub>DD4</sub>	2530	-1065	83	P9.2	-560	2135
2	SEG35	-2380	-2135	43	V <sub>DD5</sub>	2530	-915	84	P9.1	-700	2135
3	SEG34	-2240	-2135	44	C1	2530	-765	85	P9.0	-840	2135
4	SEG33	-2100	-2135	45	C2	2530	-615	86	PA.3	-980	2135
5	SEG32	-1960	-2135	46	V <sub>DDH</sub>	2530	-465	87	PA.2	-1120	2135
6	SEG31	-1820	-2135	47	CB1	2530	-315	88	PA.1	-1260	2135
7	SEG30	-1680	-2135	48	CB2	2530	-165	89	PA.0	-1400	2135
8	SEG29	-1540	-2135	49	V <sub>DD</sub>	2530	-15	90	P1.3	-1540	2135
9	SEG28	-1400	-2135	50	V <sub>DDL</sub>	2530	135	91	P1.2	-1680	2135
10	SEG27	-1260	-2135	51	OSC1	2530	285	92	P1.1	-1820	2135
11	SEG26	-1120	-2135	52	OSC0	2530	435	93	P1.0	-1960	2135
12	SEG25	-980	-2135	53	RESET	2530	585	94	P6.3	-2100	2135
13	SEG24	-840	-2135	54	XT1	2530	735	95	P6.2	-2240	2135
14	SEG23	-700	-2135	55	XT0	2530	885	96	P6.1	-2380	2135
15	SEG22	-560	-2135	56	TST2	2530	1030	97	P6.0	-2520	2135
16	SEG21	-420	-2135	57	TST1	2530	1170	98	P7.3	-2530	1607
17	SEG20	-280	-2135	58	P5.3	2530	1328	99	P7.2	-2530	1467
18	SEG19	-140	-2135	59	P5.2	2530	1468	100	P7.1	-2530	1327
19	SEG18	0	-2135	60	P5.1	2530	1608	101	P7.0	-2530	1187
20	SEG17	140	-2135	61	P5.0	2520	2135	102	BD	-2530	1029
21	SEG16	280	-2135	62	P4.3	2380	2135	103	BDB	-2530	889
22	SEG15	420	-2135	63	P4.2	2240	2135	104	V <sub>DDI</sub>	-2530	749
23	SEG14	560	-2135	64	P4.1	2100	2135	105	COM1	-2530	609
24	SEG13	700	-2135	65	P4.0	1960	2135	106	COM2	-2530	469
25	SEG12	840	-2135	66	P0.3	1820	2135	107	COM3	-2530	329
26	SEG11	980	-2135	67	P0.2	1680	2135	108	COM4	-2530	189
27	SEG10	1120	-2135	68	P0.1	1540	2135	109	COM5	-2530	49
28	SEG9	1260	-2135	69	P0.0	1400	2135	110	COM6	-2530	-91
29	SEG8	1400	-2135	70	PD.3	1260	2135	111	COM7	-2530	-231
30	SEG7	1540	-2135	71	PD.2	1120	2135	112	COM8	-2530	-371
31	SEG6	1680	-2135	72	PD.1	980	2135	113	COM9	-2530	-511
32	SEG5	1820	-2135	73	PD.0	840	2135	114	COM10	-2530	-651
33	SEG4	1960	-2135	74	PE.3	700	2135	115	COM11	-2530	-791
34	SEG3	2100	-2135	75	PE.2	560	2135	116	COM12	-2530	-931
35	SEG2	2240	-2135	76	PE.1	420	2135	117	COM13	-2530	-1071
36	SEG1	2380	-2135	77	PE.0	280	2135	118	COM14	-2530	-1211
37	SEG0	2520	-2135	78	P8.3	140	2135	119	COM15	-2530	-1351
38	V <sub>SS</sub>	2530	-1665	79	P8.2	0	2135	120	COM16	-2530	-1491
39	V <sub>DD1</sub>	2530	-1515	80	P8.1	-140	2135	121	SEG39	-2530	-1631
40	V <sub>DD2</sub>	2530	-1365	81	P8.0	-280	2135	122	SEG38	-2530	-1771
41	V <sub>DD3</sub>	2530	-1215	82	P9.3	-420	2135	123	SEG37	-2530	-1970

## PIN DESCRIPTIONS

The basic functions of each pin of the MSM63184A are described in Table 1.

A symbol with a slash (/) denotes a pin that has a secondary function.

Refer to Table 2 for secondary functions.

For type, “—” denotes a power supply pin, “I” an input pin, “O” an output pin, and “I/O” an input-output pin.

**Table 1 Pin Descriptions (Basic Functions)**

Function	Symbol	Pin	Pad No.	Type	Description
Power supply	$V_{DD}$	52	49	—	Positive power supply
	$V_{SS}$	40	38	—	Negative power supply
	$V_{DD1}$	41	39	—	Power supply pins for LCD bias (internally generated). Capacitors (0.1 $\mu$ F) should be connected between these pins and $V_{SS}$ .
	$V_{DD2}$	42	40		
	$V_{DD3}$	43	41		
	$V_{DD4}$	44	42		
	$V_{DD5}$	45	43		
	C1	46	44		
	C2	47	45	—	
	$V_{DDI}$	110	104	—	Positive power supply pin for external interface (power supply for input, output, and input-output ports)
	$V_{DDL}$	53	50	—	Positive power supply pin for internal logic (internally generated). A capacitor (0.1 $\mu$ F) should be connected between this pin and $V_{SS}$ .
	$V_{DDH}$	48	46	—	Voltage multiplier pin for power supply backup (internally generated). A capacitor (1.0 $\mu$ F) should be connected between this pin and $V_{SS}$ .
	CB1	49	47	—	Pins to connect a capacitor for voltage multiplier. A capacitor (1.0 $\mu$ F) should be connected between CB1 and CB2.
CB2	50	48	—		
Oscillation	XT0	58	55	I	Low-speed clock oscillation pins. A 32.768 kHz crystal should be connected between XT0 and XT1, and $C_G$ (5 to 25 pF) should be connected between XT0 and $V_{SS}$ .
	XT1	57	54	O	
	OSC0	55	52	I	High-speed clock oscillation pins. A ceramic resonator and capacitors ( $C_{L0}$ , $C_{L1}$ ) or external oscillation resistor ( $R_{OS}$ ) should be connected to these pins.
	OSC1	54	51	O	
Test	TST1	60	57	I	Input pins for testing. A pull-down resistor is internally connected to these pins. The user cannot use these pins.
	TST2	59	56	I	
Reset	RESET	56	53	I	Reset input pin. Setting this pin to “H” level puts this device into a reset state. Then, setting this pin to “L” level starts executing an instruction from address 0000H. A pull-down resistor is internally connected to this pin.
Buzzer	BD	108	102	O	Buzzer output pin (non-inverted output)
	BDB	109	103	O	Buzzer output pin (inverted output)



Table 1 Pin Descriptions (Basic Functions) (continued)

Function	Symbol	Pin	Pad No.	Type	Description
Port	P0.0/INT5	73	69	I	4-bit input ports. Pull-up resistor input, pull-down resistor input, or high-impedance input is selectable for each bit.
	P0.1/INT5	72	68		
	P0.2/INT5	71	67		
	P0.3/INT5	70	66		
	P1.0/INT5	97	93	I	
	P1.1/INT5	96	92		
	P1.2/INT5	95	91		
	P1.3/INT5	94	90		
	P4.0/A0	69	65	O	4-bit output ports. P-channel open drain output, N-channel open drain output, CMOS output, or high-impedance output is selectable for each bit.
	P4.1/A1	68	64		
	P4.2/A2	67	63		
	P4.3/A3	66	62		
	P5.0/A4	65	61	O	
	P5.1/A5	63	60		
	P5.2/A6	62	59		
	P5.3/A7	61	58		
P6.0/A8	101	97	O		
P6.1/A9	100	96			
P6.2/A10	99	95			
P6.3/A11	98	94			
P7.0/A12	107	101	O		
P7.1/A13	106	100			
P7.2/A14	105	99			
P7.3/A15	104	98			

Table 1 Pin Descriptions (Basic Functions) (continued)

Function	Symbol	Pin	Pad No.	Type	Description
Port	P8.0/ $\overline{RD}$	85	81	I/O	4-bit input-output ports. In input mode, pull-up resistor input, pull-down resistor input, or high-impedance input is selectable for each bit. In output mode, P-channel open drain output, N-channel open drain output, CMOS output, or high-impedance output is selectable for each bit.
	P8.1/ $\overline{WR}$	84	80		
	P8.2	83	79		
	P8.3/INT4	82	78		
	P9.0/D0	89	85	I/O	
	P9.1/D1	88	84		
	P9.2/D2	87	83		
	P9.3/D3	86	82	I/O	
	PA.0/D4	93	89		
	PA.1/D5	92	88		
	PA.2/D6	91	87		
	PA.3/D7	90	86	I/O	
	PD.0/FRAME	77	73		
	PD.1/LCLK	76	72		
	PD.2/TBCCLK	75	71		
	PD.3/HSCLK	74	70	I/O	
PE.0/SIN	81	77			
PE.1/SOUT	80	76			
PE.2/SCLK	79	75			
PE.3/INT2	78	74			

Table 1 Pin Descriptions (Basic Functions) (continued)

Function	Symbol	Pin	Pad No.	Type	Description
LCD	COM1	111	105	O	LCD common signal output pins
	COM2	112	106		
	COM3	113	107		
	COM4	114	108		
	COM5	115	109		
	COM6	116	110		
	COM7	117	111		
	COM8	118	112		
	COM9	119	113		
	COM10	120	114		
	COM11	121	115		
	COM12	122	116		
	COM13	123	117		
	COM14	124	118		
	COM15	125	119		
	COM16	126	120		
	SEG0	38	37	O	LCD segment signal output pins
	SEG1	37	36		
	SEG2	36	35		
	SEG3	35	34		
	SEG4	34	33		
	SEG5	33	32		
	SEG6	32	31		
	SEG7	31	30		
SEG8	30	29			
SEG9	29	28			
SEG10	28	27			
SEG11	27	26			
SEG12	26	25			
SEG13	25	24			
SEG14	24	23			
SEG15	23	22			
SEG16	22	21			
SEG17	21	20			
SEG18	20	19			
SEG19	19	18			
SEG20	18	17			
SEG21	17	16			
SEG22	16	15			
SEG23	15	14			
SEG24	14	13			

Table 1 Pin Descriptions (Basic Functions) (continued)

Function	Symbol	Pin	Pad No.	Type	Description
LCD	SEG25	13	12	O	LCD segment signal output pins
	SEG26	12	11		
	SEG27	11	10		
	SEG28	10	9		
	SEG29	9	8		
	SEG30	8	7		
	SEG31	7	6		
	SEG32	6	5		
	SEG33	5	4		
	SEG34	4	3		
	SEG35	3	2		
	SEG36	2	1		
	SEG37	1	123		
	SEG38	128	122		
	SEG39	127	121		

Table 2 shows the secondary functions of each pin of the MSM63184A.

**Table 2 Pin Descriptions (Secondary Functions)**

Function	Symbol	Pin	Pad No.	Type	Description
External Interrupt	PE.3/INT2	78	74	I	External 2 interrupt input pin. The change of input signal level causes an interrupt to occur.
	P8.3/INT4	82	78	I	External 4 interrupt input pin. The change of input signal level causes an interrupt to occur.
	P0.0/INT5	73	69	I	External 5 interrupt input pins. The change of input signal level causes an interrupt to occur. The Port 0 Interrupt Enable register (P0IE) and Port 1 Interrupt Enable register (P1IE) enable or disable an interrupt for each bit.
	P0.1/INT5	72	68		
	P0.2/INT5	71	67		
	P0.3/INT5	70	66		
	P1.0/INT5	97	93		
	P1.1/INT5	96	92		
	P1.2/INT5	95	91		
	P1.3/INT5	94	90		
LCD External Expansion	PD.0/FRAME	77	73	O	Frame output pin for LCD driver expansion
	PD.1/LCLK	76	72	O	Clock output pin for LCD driver expansion
Oscillation Output	PD.2/TBCCLK	75	71	O	Low-speed oscillation clock output pin
	PD.3/HSCLK	74	70	O	High-speed oscillation clock output pin
Shift Register	PE.0/SIN	81	77	I	Shift register receive data input pin
	PE.1/SOUT	80	76	O	Shift register transmit data output pin
	PE.2/SCLK	79	75	O	Shift register clock input-output pin. Clock output when this device is used as a master processor. Clock input when this device is used as a slave processor.

Table 2 Pin Descriptions (Secondary Functions) (continued)

Function	Symbol	Pin	Pad No.	Type	Description
External Memory	P4.0/A0	69	65	O	Address output bus for external memory
	P4.1/A1	68	64		
	P4.2/A2	67	63		
	P4.3/A3	66	62		
	P5.0/A4	65	61		
	P5.1/A5	63	60		
	P5.2/A6	62	59		
	P5.3/A7	61	58		
	P6.0/A8	101	97		
	P6.1/A9	100	96		
	P6.2/A10	99	95		
	P6.3/A11	98	94		
	P7.0/A12	107	101		
	P7.1/A13	106	100		
	P7.2/A14	105	99		
P7.3/A15	104	98			
External Memory	P9.0/D0	89	85	I/O	Data bus for external memory
	P9.1/D1	88	84		
	P9.2/D2	87	83		
	P9.3/D3	86	82		
	PA.0/D4	93	89		
	PA.1/D5	92	88		
	PA.2/D6	91	87		
	PA.3/D7	90	86		
P8.0/ $\overline{RD}$	85	81	O	Read signal output pin for external memory (negative logic)	
P8.1/ $\overline{WR}$	84	80	O	Write signal output pin for external memory (negative logic)	

**ABSOLUTE MAXIMUM RATINGS** $(V_{SS} = 0 \text{ V})$ 

Parameter	Symbol	Condition	Rating	Unit
Power Supply Voltage 1	$V_{DD1}$	$T_a = 25^\circ\text{C}$	-0.3 to +1.6	V
Power Supply Voltage 2	$V_{DD2}$	$T_a = 25^\circ\text{C}$	-0.3 to +2.9	V
Power Supply Voltage 3	$V_{DD3}$	$T_a = 25^\circ\text{C}$	-0.3 to +4.2	V
Power Supply Voltage 4	$V_{DD4}$	$T_a = 25^\circ\text{C}$	-0.3 to +5.5	V
Power Supply Voltage 5	$V_{DD5}$	$T_a = 25^\circ\text{C}$	-0.3 to +6.8	V
Power Supply Voltage 6	$V_{DD}$	$T_a = 25^\circ\text{C}$	-0.3 to +6.0	V
Power Supply Voltage 7	$V_{DDI}$	$T_a = 25^\circ\text{C}$	-0.3 to +6.0	V
Power Supply Voltage 8	$V_{DDH}$	$T_a = 25^\circ\text{C}$	-0.3 to +6.0	V
Power Supply Voltage 9	$V_{DDL}$	$T_a = 25^\circ\text{C}$	-0.3 to +6.0	V
Input Voltage 1	$V_{IN1}$	$V_{DD}$ Input, $T_a = 25^\circ\text{C}$	-0.3 to $V_{DD} + 0.3$	V
Input Voltage 2	$V_{IN2}$	$V_{DDI}$ Input, $T_a = 25^\circ\text{C}$	-0.3 to $V_{DDI} + 0.3$	V
Output Voltage 1	$V_{OUT1}$	$V_{DD1}$ Output, $T_a = 25^\circ\text{C}$	-0.3 to $V_{DD1} + 0.3$	V
Output Voltage 2	$V_{OUT2}$	$V_{DD2}$ Output, $T_a = 25^\circ\text{C}$	-0.3 to $V_{DD2} + 0.3$	V
Output Voltage 3	$V_{OUT3}$	$V_{DD3}$ Output, $T_a = 25^\circ\text{C}$	-0.3 to $V_{DD3} + 0.3$	V
Output Voltage 4	$V_{OUT4}$	$V_{DD4}$ Output, $T_a = 25^\circ\text{C}$	-0.3 to $V_{DD4} + 0.3$	V
Output Voltage 5	$V_{OUT5}$	$V_{DD5}$ Output, $T_a = 25^\circ\text{C}$	-0.3 to $V_{DD5} + 0.3$	V
Output Voltage 6	$V_{OUT6}$	$V_{DD}$ Output, $T_a = 25^\circ\text{C}$	-0.3 to $V_{DD} + 0.3$	V
Output Voltage 7	$V_{OUT7}$	$V_{DDI}$ Output, $T_a = 25^\circ\text{C}$	-0.3 to $V_{DDI} + 0.3$	V
Output Voltage 8	$V_{OUT8}$	$V_{DDH}$ Output, $T_a = 25^\circ\text{C}$	-0.3 to $V_{DDH} + 0.3$	V
Storage Temperature	$T_{STG}$	—	-55 to +150	$^\circ\text{C}$

**RECOMMENDED OPERATING CONDITIONS**

- When backup is used

(V<sub>SS</sub> = 0 V)

Parameter	Symbol	Condition	Range	Unit
Operating Temperature	T <sub>op</sub>	—	-20 to +70	°C
Operating Voltage	V <sub>DD</sub>	—	0.9 to 2.7	V
	V <sub>DDI</sub>	—	0.9 to 5.5	V
Crystal Oscillation Frequency	f <sub>XT</sub>	—	30 to 35	kHz
Ceramic Oscillation Frequency	f <sub>CM</sub>	V <sub>DD</sub> = 1.2 to 2.7 V	300k to 500k	Hz
		V <sub>DD</sub> = 1.5 to 2.7 V	200k to 1M	
External RC Oscillator Resistance	R <sub>OS</sub>	V <sub>DD</sub> = 1.2 to 2.7 V	100 to 300	kΩ
		V <sub>DD</sub> = 1.5 to 2.7 V	50 to 300	

- When backup is not used

(V<sub>SS</sub> = 0 V)

Parameter	Symbol	Condition	Range	Unit
Operating Temperature	T <sub>op</sub>	—	-20 to +70	°C
Operating Voltage	V <sub>DD</sub>	—	1.8 to 5.5	V
	V <sub>DDI</sub>	—	1.8 to 5.5	V
Crystal Oscillation Frequency	f <sub>XT</sub>	—	30 to 35	kHz
Ceramic Oscillation Frequency	f <sub>CM</sub>	V <sub>DD</sub> = 1.8 to 5.5 V	300k to 500k	Hz
		V <sub>DD</sub> = 2.2 to 5.5 V	300k to 1M	
		V <sub>DD</sub> = 2.7 to 5.5 V	200k to 2M	
External RC Oscillator Resistance	R <sub>OS</sub>	V <sub>DD</sub> = 1.8 to 5.5 V	100 to 300	kΩ
		V <sub>DD</sub> = 2.2 to 5.5 V	50 to 300	
		V <sub>DD</sub> = 2.7 to 5.5 V	30 to 300	



- High-speed RC oscillation characteristics (Typ.)  
When backup is used ( $V_{DD} = V_{DDI} = 1.5\text{ V}$ )

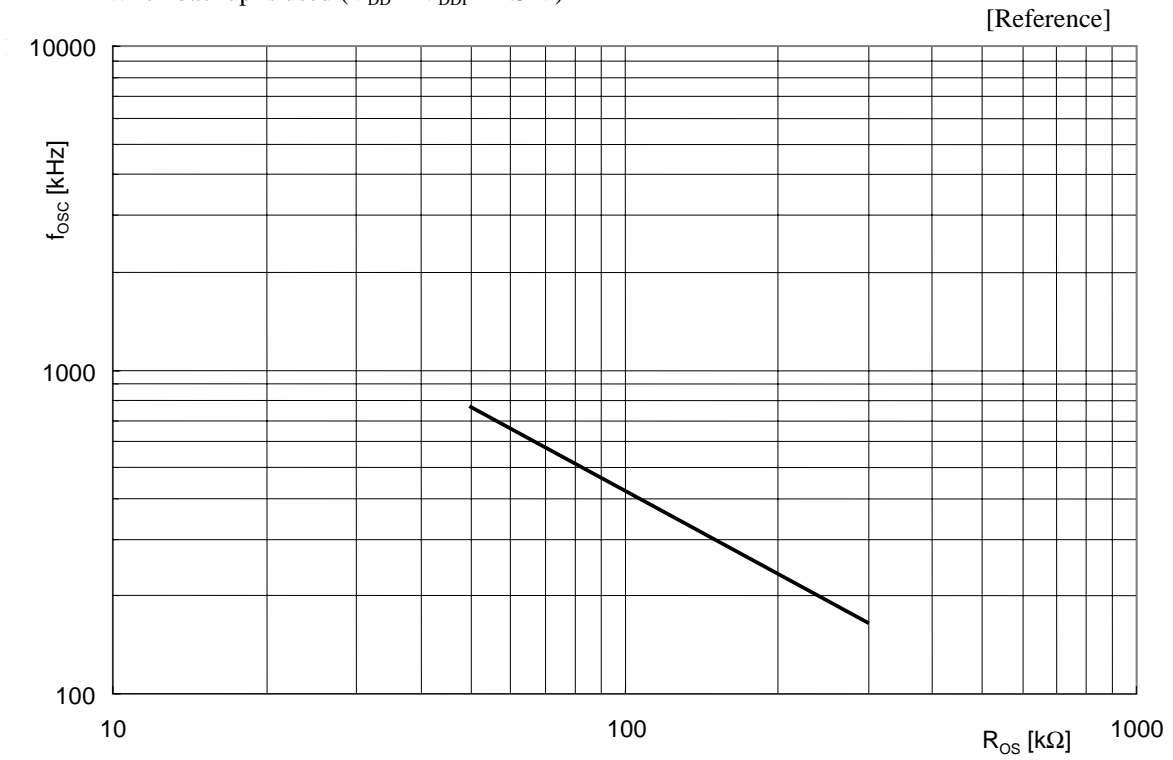

- High-speed RC oscillation characteristics (Typ.)  
When backup is not used ( $V_{DD} = V_{DDI} = 3.0\text{ V}$ )

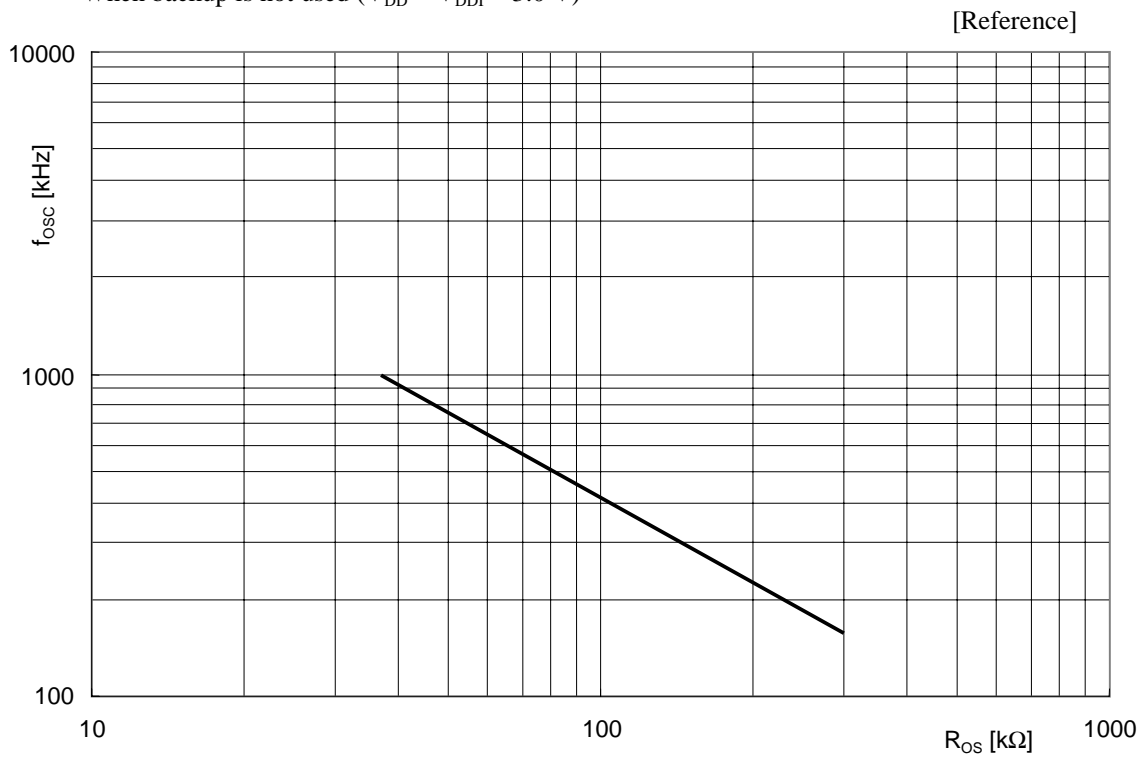

## ELECTRICAL CHARACTERISTICS

## DC Characteristics

(V<sub>SS</sub> = V<sub>DDI</sub> = 0.9 to 5.5 V, V<sub>SS</sub> = 0 V, Ta = -20 to +70°C unless otherwise specified)

Parameter	Symbol	Condition	Min.	Typ.	Max.	Unit	Measuring Circuit
V <sub>DD2</sub> Voltage	V <sub>DD2</sub>	1/5 bias, 1/4 bias (Ta = 25°C)	1.7	1.8	1.9	V	1
V <sub>DD2</sub> Voltage Temperature Deviation	ΔV <sub>DD2</sub>	—	—	-4	—	mV/°C	
V <sub>DD1</sub> Voltage	V <sub>DD1</sub>	1/5 bias, 1/4 bias	Typ. - 0.1	1/2 × V <sub>DD2</sub>	Typ. + 0.1	V	
V <sub>DD3</sub> Voltage	V <sub>DD3</sub>	1/5 bias	Typ. - 0.3	3/2 × V <sub>DD2</sub>	Typ. + 0.3	V	
		1/4 bias (connect V <sub>DD3</sub> and V <sub>DD2</sub> )	Typ. - 0.2	V <sub>DD2</sub>	Typ. + 0.2		
V <sub>DD4</sub> Voltage	V <sub>DD4</sub>	1/5 bias	Typ. - 0.4	2 × V <sub>DD2</sub>	Typ. + 0.4	V	
		1/4 bias	Typ. - 0.3	3/2 × V <sub>DD2</sub>	Typ. + 0.3		
V <sub>DD5</sub> Voltage	V <sub>DD5</sub>	1/5 bias	Typ. - 0.5	5/2 × V <sub>DD2</sub>	Typ. + 0.5	V	
		1/4 bias	Typ. - 0.4	2 × V <sub>DD2</sub>	Typ. + 0.4		
V <sub>DDH</sub> Voltage (Backup used)	V <sub>DDH</sub>	High-speed clock oscillation stopped V <sub>DD</sub> = 1.5 V	2.8	—	3.0	V	
		High-speed clock oscillation (Ceramic oscillation, 1 MHz V <sub>DD</sub> = 1.5 V)	2.0	—	2.7	V	
V <sub>DDL</sub> Voltage	V <sub>DDL</sub>	High-speed clock oscillation stopped	0.8	1.3	1.8	V	
		High-speed clock oscillation (V <sub>DD</sub> = 1.2 to 5.5 V)	1.2	—	5.5	V	
Crystal Oscillation Start Voltage	V <sub>STA</sub>	Oscillation start time: within 5 seconds	1.0	—	—	V	
Crystal Oscillation Hold Voltage	V <sub>HOLD</sub>	Backup	0.9	—	—	V	
		Backup not used	1.7	—	—	V	
Crystal Oscillation Stop Detect Time	T <sub>STOP</sub>	—	0.1	—	5.0	ms	
External Crystal Oscillator Capacitance	C <sub>G</sub>	—	5	—	25	pF	
Internal Crystal Oscillator Capacitance	C <sub>D</sub>	—	20	25	30	pF	
External Ceramic Oscillator Capacitance	C <sub>LO, 1</sub>	CSA2.00MG (Murata MFG.- make) used V <sub>DD</sub> = 3.0 V	—	30	—	pF	
Internal RC Oscillator Capacitance	C <sub>OS</sub>	—	8	12	16	pF	
POR Voltage	V <sub>POR1</sub>	V <sub>DD</sub> = 1.5 V	0	—	0.4	V	
		V <sub>DD</sub> = 3.0 V	0	—	0.7	V	
Non-POR Voltage	V <sub>POR2</sub>	V <sub>DD</sub> = 1.5 V	1.2	—	1.5	V	
		V <sub>DD</sub> = 3.0 V	2.0	—	3.0	V	

- Notes: 1. "V<sub>DD</sub>" varies in the range of 1.8 to 2.4 V depending on the value of the display contrast register (DSPCNT).  
2. "T<sub>STOP</sub>" indicates that if the crystal oscillator stops over the value of T<sub>STOP</sub>, the system reset occurs.  
3. "POR" denotes Power On Reset.  
4. "V<sub>POR1</sub>" indicates that POR occurs when V<sub>DD</sub> falls from V<sub>DD</sub> to V<sub>POR1</sub> and again rises up to V<sub>DD</sub>.  
5. "V<sub>POR2</sub>" indicates that POR does not occur when V<sub>DD</sub> falls from V<sub>DD</sub> to V<sub>POR2</sub> and again rises up to V<sub>DD</sub>.

**DC Characteristics (continued)**

- When backup is used

( $V_{DD} = V_{DD1} = 1.5\text{ V}$ ,  $V_{SS} = 0\text{ V}$ , 1/5 bias, DSPCNT = 0H,  $T_a = -20\text{ to }+70^\circ\text{C}$  unless otherwise specified)

Parameter	Symbol	Condition	Min.	Typ.	Max.	Unit	Measuring Circuit	
Supply Current 1	$I_{DD1}$	CPU is in HALT state. (High-speed clock oscillation stopped)	$T_a = -20\text{ to }+50^\circ\text{C}$	—	5.3	6.5	$\mu\text{A}$	1
			$T_a = -20\text{ to }+70^\circ\text{C}$	—	5.3	8.0		
Supply Current 2	$I_{DD2}$	CPU is in HALT state. LCD is in Power Down mode. (High-speed clock oscillation stopped)	$T_a = -20\text{ to }+50^\circ\text{C}$	—	4.2	5.0	$\mu\text{A}$	
			$T_a = -20\text{ to }+70^\circ\text{C}$	—	4.2	6.5		
Supply Current 3	$I_{DD3}$	CPU is in operation at low-speed oscillation. (High-speed clock oscillation stopped)	—	15	20	$\mu\text{A}$		
Supply Current 4	$I_{DD4}$	CPU is in operation at high-speed oscillation (RC oscillation, $f = \text{approx. } 720\text{ kHz}$ , $R_{OS} = 51\text{ k}\Omega$ )	—	600	800	$\mu\text{A}$		
Supply Current 5	$I_{DD5}$	CPU is in operation at high-speed oscillation (Ceramic oscillation, 1 MHz)	—	700	900	$\mu\text{A}$		

- When backup is not used

( $V_{DD} = V_{DD1} = 3.0\text{ V}$ ,  $V_{SS} = 0\text{ V}$ , 1/5 bias, DSPCNT = 0H,  $T_a = -20\text{ to }+70^\circ\text{C}$  unless otherwise specified)

Parameter	Symbol	Condition	Min.	Typ.	Max.	Unit	Measuring Circuit	
Supply Current 1	$I_{DD1}$	CPU is in HALT state. (High-speed clock oscillation stopped)	$T_a = -20\text{ to }+50^\circ\text{C}$	—	2.4	2.9	$\mu\text{A}$	1
			$T_a = -20\text{ to }+70^\circ\text{C}$	—	2.4	3.4		
Supply Current 2	$I_{DD2}$	CPU is in HALT state. LCD is in Power Down mode. (High-speed clock oscillation stopped)	$T_a = -20\text{ to }+50^\circ\text{C}$	—	1.8	2.2	$\mu\text{A}$	
			$T_a = -20\text{ to }+70^\circ\text{C}$	—	1.8	2.8		
Supply Current 3	$I_{DD3}$	CPU is in operation at low-speed oscillation. (High-speed clock oscillation stopped)	—	7.2	9.0	$\mu\text{A}$		
Supply Current 4	$I_{DD4}$	CPU is in operation at high-speed oscillation (RC oscillation)	$f = \text{approx. } 800\text{ kHz}$ , $R_{OS} = 51\text{ k}\Omega$	—	450	600	$\mu\text{A}$	
			$f = \text{approx. } 500\text{ kHz}$ , $R_{OS} = 100\text{ k}\Omega$	—	350	450		
Supply Current 5	$I_{DD5}$	CPU is in operation at high-speed oscillation (Ceramic oscillation, 2 MHz)	—	850	1000	$\mu\text{A}$		

## DC Characteristics (continued)

( $V_{DD} = V_{DD1} = V_{DDH} = 3.0\text{ V}$ ,  $V_{SS} = 0\text{ V}$ ,  $V_{DD1} = 1.1\text{ V}$ ,  $V_{DD2} = 2.2\text{ V}$ ,  $V_{DD3} = 3.3\text{ V}$ ,  
 $V_{DD4} = 4.4\text{ V}$ ,  $V_{DD5} = 5.5\text{ V}$ ,  $T_a = -20\text{ to }+70^\circ\text{C}$  unless otherwise specified)

Parameter	Symbol	Condition	Min.	Typ.	Max.	Unit	Measuring Circuit	
Output Current 1 (P4.0 to P4.3) (P5.0 to P5.3) (P6.0 to P6.3) ⋮ (PD.0 to PD.3) (PE.0 to PE.3)	$I_{OH1}$	$V_{OH1} = V_{DD1} - 0.5\text{ V}$	$V_{DD1} = 1.5\text{ V}$	-2.0	-1.2	-0.2	mA	2
			$V_{DD1} = 3.0\text{ V}$	-5.0	-3.0	-1.0	mA	
			$V_{DD1} = 5.0\text{ V}$	-8.0	-4.0	-1.5	mA	
	$I_{OL1}$	$V_{OL1} = 0.5\text{ V}$	$V_{DD1} = 1.5\text{ V}$	0.2	1.2	2.0	mA	
			$V_{DD1} = 3.0\text{ V}$	1.0	3.0	5.0	mA	
			$V_{DD1} = 5.0\text{ V}$	1.5	4.0	8.0	mA	
Output Current 2 (BD, BDB)	$I_{OH2}$	$V_{OH2} = V_{DD} - 0.7\text{ V}$	$V_{DD} = 1.5\text{ V}$	-2.5	-1.3	-0.4	mA	
			$V_{DD} = 3.0\text{ V}$	-6.0	-4.0	-2.0	mA	
			$V_{DD} = V_{DDH} = 5.0\text{ V}$	-9.0	-5.5	-3.0	mA	
	$I_{OL2}$	$V_{OL2} = 0.7\text{ V}$	$V_{DD} = 1.5\text{ V}$	0.4	1.3	2.5	mA	
			$V_{DD} = 3.0\text{ V}$	2.0	4.0	6.0	mA	
			$V_{DD} = V_{DDH} = 5.0\text{ V}$	3.0	5.5	9.0	mA	
Output Current 3 (SEG0 to SEG39) (COM1 to COM16)	$I_{OH3}$	$V_{OH3} = V_{DD5} - 0.2\text{ V}$ ( $V_{DD5}$ level)	—	—	-4	$\mu\text{A}$		
	$I_{OHM3}$	$V_{OHM3} = V_{DD4} + 0.2\text{ V}$ ( $V_{DD4}$ level)	4	—	—	$\mu\text{A}$		
	$I_{OHM3S}$	$V_{OHM3S} = V_{DD4} - 0.2\text{ V}$ ( $V_{DD4}$ level)	—	—	-4	$\mu\text{A}$		
	$I_{OMH3}$	$V_{OMH3} = V_{DD3} + 0.2\text{ V}$ ( $V_{DD3}$ level)	4	—	—	$\mu\text{A}$		
	$I_{OMH3S}$	$V_{OMH3S} = V_{DD3} - 0.2\text{ V}$ ( $V_{DD3}$ level)	—	—	-4	$\mu\text{A}$		
	$I_{OML3}$	$V_{OML3} = V_{DD2} + 0.2\text{ V}$ ( $V_{DD2}$ level)	4	—	—	$\mu\text{A}$		
	$I_{OML3S}$	$V_{OML3S} = V_{DD2} - 0.2\text{ V}$ ( $V_{DD2}$ level)	—	—	-4	$\mu\text{A}$		
	$I_{OLM3}$	$V_{OLM3} = V_{DD1} + 0.2\text{ V}$ ( $V_{DD1}$ level)	4	—	—	$\mu\text{A}$		
	$I_{OLM3S}$	$V_{OLM3S} = V_{DD1} - 0.2\text{ V}$ ( $V_{DD1}$ level)	—	—	-4	$\mu\text{A}$		
$I_{OL3}$	$V_{OL3} = V_{SS} + 0.2\text{ V}$ ( $V_{SS}$ level)	4	—	—	$\mu\text{A}$			
Output Current 4 (OSC1)	$I_{OH4R}$	$V_{OH4R} = V_{DDH} - 0.5\text{ V}$ (RC oscillation)	$V_{DD} = V_{DDH} = 3.0\text{ V}$	-2.5	-1.5	-0.75	mA	
			$V_{DD} = V_{DDH} = 5.0\text{ V}$	-3.5	-2.0	-1.0	mA	
	$I_{OL4R}$	$V_{OL4R} = 0.5\text{ V}$ (RC oscillation)	$V_{DD} = V_{DDH} = 3.0\text{ V}$	0.75	1.5	2.5	mA	
			$V_{DD} = V_{DDH} = 5.0\text{ V}$	1.0	2.0	3.5	mA	
	$I_{OH4C}$	$V_{OH4C} = V_{DDH} - 0.5\text{ V}$ (ceramic oscillation)	$V_{DD} = V_{DDH} = 3.0\text{ V}$	-300	-180	-60	$\mu\text{A}$	
			$V_{DD} = V_{DDH} = 5.0\text{ V}$	-450	-280	-100	$\mu\text{A}$	
	$I_{OL4C}$	$V_{OL4C} = 0.5\text{ V}$ (ceramic oscillation)	$V_{DD} = V_{DDH} = 3.0\text{ V}$	60	180	300	$\mu\text{A}$	
			$V_{DD} = V_{DDH} = 5.0\text{ V}$	100	280	450	$\mu\text{A}$	
Output Leakage (P4.0 to P4.3) (P5.0 to P5.3) (P6.0 to P6.3) ⋮ (PE.0 to PE.3)	$I_{OOH}$	$V_{OH} = V_{DD1}$	—	—	0.3	$\mu\text{A}$		
	$I_{OOL}$	$V_{OL} = V_{SS}$	-0.3	—	—	$\mu\text{A}$		

## DC Characteristics (continued)

( $V_{DD} = V_{DD1} = V_{DDH} = 3.0\text{ V}$ ,  $V_{SS} = 0\text{ V}$ ,  $V_{DD1} = 1.1\text{ V}$ ,  $V_{DD2} = 2.2\text{ V}$ ,  $V_{DD3} = 3.3\text{ V}$ ,  
 $V_{DD4} = 4.4\text{ V}$ ,  $V_{DD5} = 5.5\text{ V}$ ,  $T_a = -20\text{ to }+70^\circ\text{C}$  unless otherwise specified)

Parameter	Symbol	Condition	Min.	Typ.	Max.	Unit	Measuring Circuit	
Input Current 1 (P0.0 to P0.3) (P1.0 to P1.3) (P8.0 to P8.3) (P9.0 to P9.3) ⋮ (PE.0 to PE.3)	$I_{IH1}$	$V_{IH1} = V_{DD1}$ (when pulled down)	$V_{DD1} = 1.5\text{ V}$	2	10	30	$\mu\text{A}$	3
			$V_{DD1} = 3.0\text{ V}$	30	90	180	$\mu\text{A}$	
			$V_{DD1} = 5.0\text{ V}$	70	250	600	$\mu\text{A}$	
	$I_{IL1}$	$V_{IL1} = V_{SS}$ (when pulled up)	$V_{DD1} = 1.5\text{ V}$	-30	-10	-2	$\mu\text{A}$	
			$V_{DD1} = 3.0\text{ V}$	-180	-90	-30	$\mu\text{A}$	
			$V_{DD1} = 5.0\text{ V}$	-600	-250	-70	$\mu\text{A}$	
$I_{IH1Z}$	$V_{IH1} = V_{DD1}$ (in a high impedance state)	0	—	1	$\mu\text{A}$			
$I_{IL1Z}$	$V_{IL1} = V_{SS}$ (in a high impedance state)	-1	—	0	$\mu\text{A}$			
Input Current 2 (OSC0)	$I_{IL2}$	$V_{IL2} = V_{SS}$ (when pulled up)	$V_{DD} = V_{DDH} = 3.0\text{ V}$	-200	-110	-30	$\mu\text{A}$	
			$V_{DD} = V_{DDH} = 5.0\text{ V}$	-600	-350	-150	$\mu\text{A}$	
	$I_{IH2R}$	$V_{IH2R} = V_{DDH}$ (RC oscillation)	0	—	1	$\mu\text{A}$		
	$I_{IL2R}$	$V_{IL2R} = V_{SS}$ (RC oscillation)	-1	—	0	$\mu\text{A}$		
	$I_{IH2C}$	$V_{IH2C} = V_{DDH}$ (ceramic oscillation)	$V_{DD} = V_{DDH} = 3.0\text{ V}$	0.1	0.5	1.0	$\mu\text{A}$	
			$V_{DD} = V_{DDH} = 5.0\text{ V}$	0.75	1.5	3.0	$\mu\text{A}$	
$I_{IL2C}$	$V_{IL2C} = V_{SS}$ (ceramic oscillation)	$V_{DD} = V_{DDH} = 3.0\text{ V}$	-1.0	-0.5	-0.1	$\mu\text{A}$		
		$V_{DD} = V_{DDH} = 5.0\text{ V}$	-3.0	-1.5	-0.75	$\mu\text{A}$		
Input Current 3 (RESET)	$I_{IH3}$	$V_{IH3} = V_{DD}$	$V_{DD} = 1.5\text{ V}$	10	50	80	$\mu\text{A}$	
			$V_{DD} = 3.0\text{ V}$	150	350	600	$\mu\text{A}$	
			$V_{DD} = V_{DDH} = 5.0\text{ V}$	0.5	1.0	2.0	$\text{mA}$	
	$I_{IL3}$	$V_{IL3} = V_{SS}$	-1	—	0	$\mu\text{A}$		
Input Current 4 (TST1, TST2)	$I_{IH4}$	$V_{IH4} = V_{DD}$	$V_{DD} = 1.5\text{ V}$	50	150	300	$\mu\text{A}$	
			$V_{DD} = 3.0\text{ V}$	0.5	1.0	1.5	$\text{mA}$	
			$V_{DD} = V_{DDH} = 5.0\text{ V}$	1.25	2.5	4.0	$\text{mA}$	
	$I_{IL4}$	$V_{IL4} = V_{SS}$	-1	—	0	$\mu\text{A}$		

## DC Characteristics (continued)

( $V_{DD} = V_{DD1} = V_{DDH} = 3.0\text{ V}$ ,  $V_{SS} = 0\text{ V}$ ,  $V_{DD1} = 1.1\text{ V}$ ,  $V_{DD2} = 2.2\text{ V}$ ,  $V_{DD3} = 3.3\text{ V}$ ,  
 $V_{DD4} = 4.4\text{ V}$ ,  $V_{DD5} = 5.5\text{ V}$ ,  $T_a = -20\text{ to }+70^\circ\text{C}$  unless otherwise specified)

Parameter	Symbol	Condition	Min.	Typ.	Max.	Unit	Measuring Circuit
Input Voltage 1 (P0.0 to P0.3) (P1.0 to P1.3) (P8.0 to P8.3) (P9.0 to P9.3) ⋮ (PE.0 to PE.3)	$V_{IH1}$	$V_{DD1} = 1.5\text{ V}$	1.2	—	1.5	V	4
		$V_{DD1} = 3.0\text{ V}$	2.4	—	3.0	V	
		$V_{DD1} = 5.0\text{ V}$	4.0	—	5.0	V	
	$V_{IL1}$	$V_{DD1} = 1.5\text{ V}$	0	—	0.3	V	
		$V_{DD1} = 3.0\text{ V}$	0	—	0.6	V	
		$V_{DD1} = 5.0\text{ V}$	0	—	1	V	
Input Voltage 2 (OSC0)	$V_{IH2}$	$V_{DD} = V_{DDH} = 3.0\text{ V}$	2.4	—	3.0	V	
		$V_{DD} = V_{DDH} = 5.0\text{ V}$	4.0	—	5.0	V	
	$V_{IL2}$	$V_{DD} = V_{DDH} = 3.0\text{ V}$	0	—	0.6	V	
		$V_{DD} = V_{DDH} = 5.0\text{ V}$	0	—	1	V	
Input Voltage 3 (RESET, TST1, TST2)	$V_{IH3}$	$V_{DD} = 1.5\text{ V}$	1.35	—	1.5	V	
		$V_{DD} = 3.0\text{ V}$	2.4	—	3.0	V	
		$V_{DD} = V_{DDH} = 5.0\text{ V}$	4.0	—	5.0	V	
	$V_{IL3}$	$V_{DD} = 1.5\text{ V}$	0	—	0.15	V	
		$V_{DD} = 3.0\text{ V}$	0	—	0.6	V	
		$V_{DD} = V_{DDH} = 5.0\text{ V}$	0	—	1	V	
Hysteresis Width 1 (P0.0 to P0.3) (P1.0 to P1.3) (P8.0 to P8.3)  (PE.0 to PE.3)	$\Delta V_{T1}$	$V_{DD1} = 1.5\text{ V}$	0.05	0.1	0.3	V	
		$V_{DD1} = 3.0\text{ V}$	0.2	0.5	1.0	V	
		$V_{DD1} = 5.0\text{ V}$	0.25	1.0	1.5	V	
Hysteresis Width 2 (RESET, TST1, TST2)	$\Delta V_{T2}$	$V_{DD} = 1.5\text{ V}$	0.05	0.1	0.3	V	
		$V_{DD} = 3.0\text{ V}$	0.2	0.5	1.0	V	
		$V_{DD} = V_{DDH} = 5.0\text{ V}$	0.25	1.0	1.5	V	
Input Pin Capacitance (P0.0 to P0.3) (P1.0 to P1.3) (P8.0 to P8.3) (P9.0 to P9.3) ⋮ (PD.0 to PD.3) (PE.0 to PE.3)	$C_{IN}$	—	—	—	5	pF	1

Measuring circuit 1

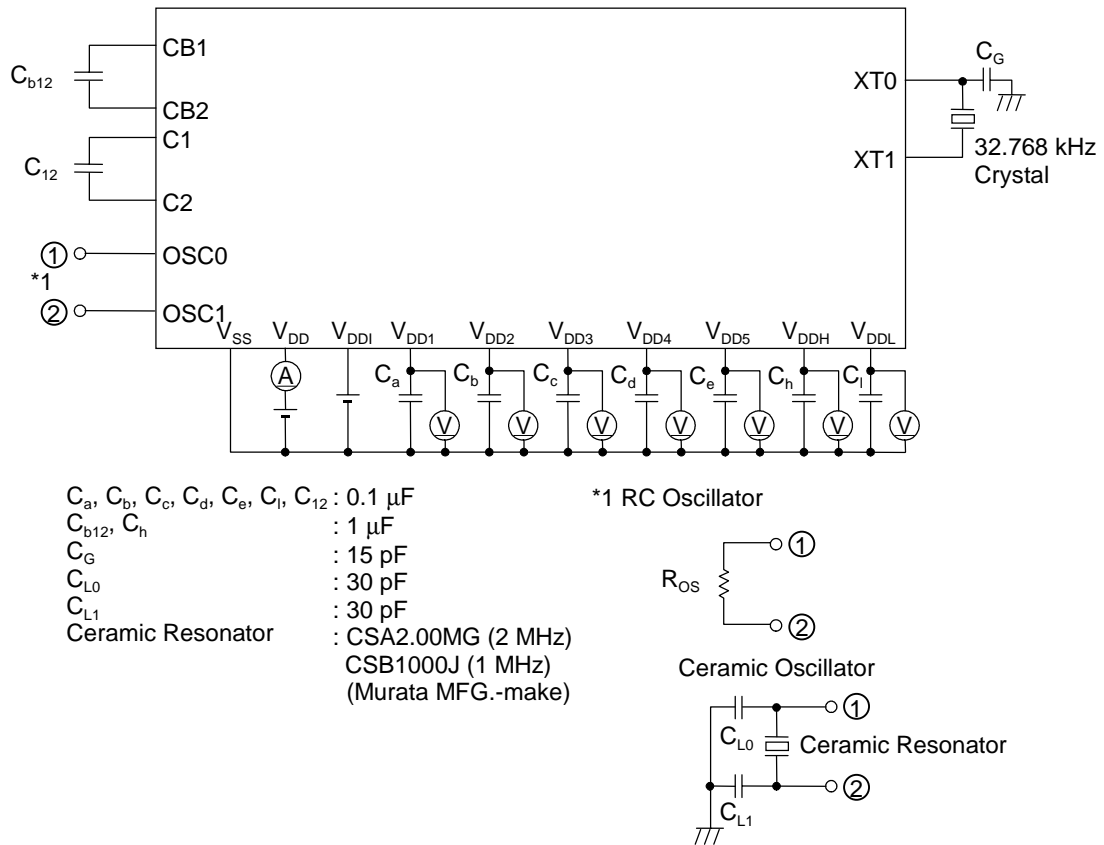

Measuring circuit 2

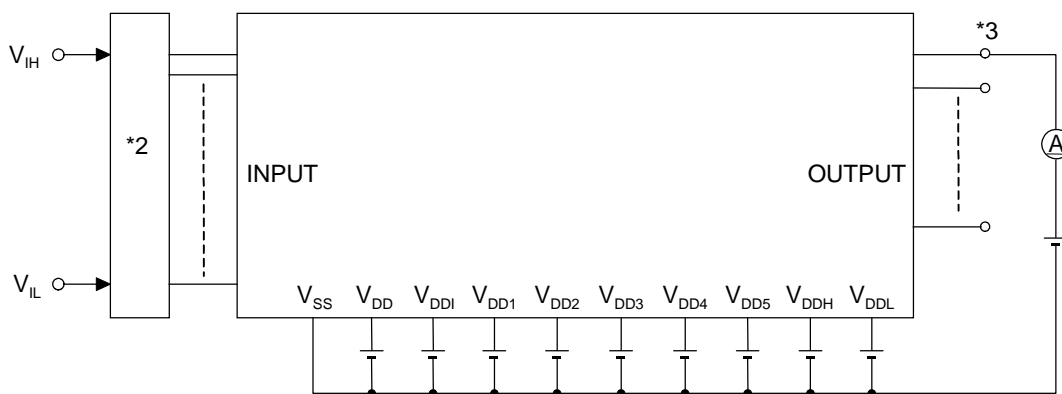

\*2 Input logic circuit to determine the specified measuring conditions.  
 \*3 Measured at the specified output pins.

Measuring circuit 3

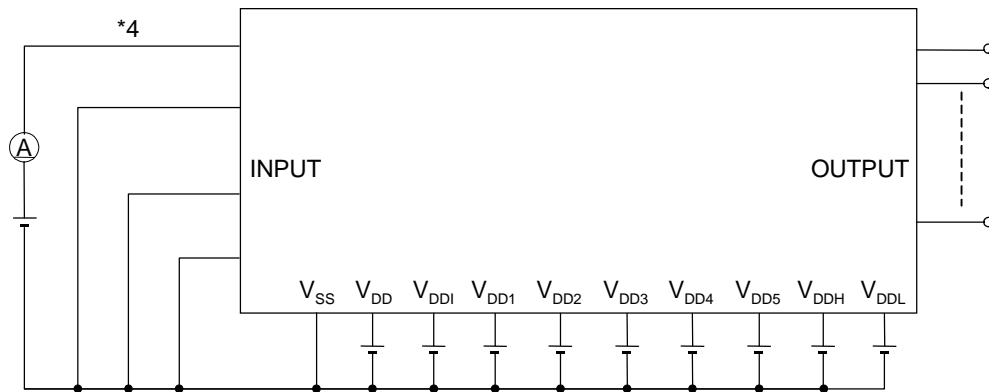

Measuring circuit 4

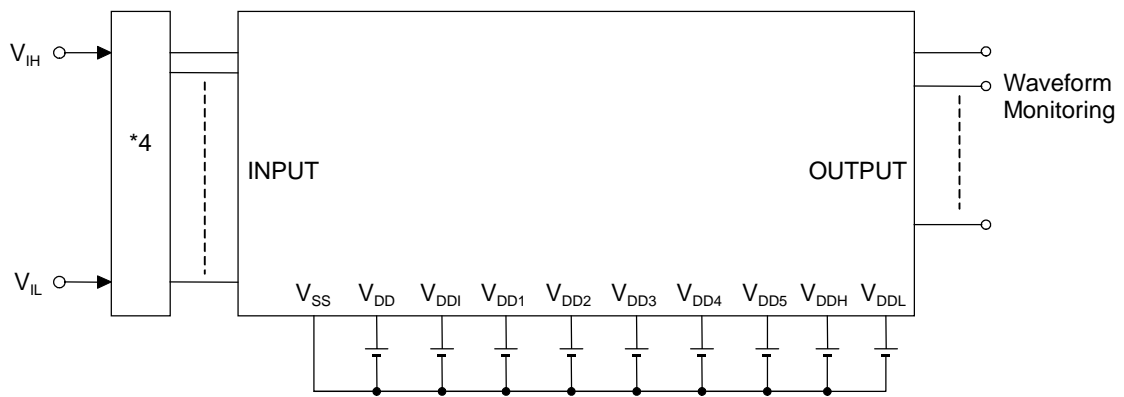

\*4 Measured at the specified input pins.



**AC Characteristics (Serial Interface, Shift Register)**

( $V_{DD} = 0.9$  to  $5.5$  V,  $V_{DDH} = 1.8$  to  $5.5$  V,  $V_{SS} = 0$  V,  $V_{DDI} = 5.0$  V,  $T_a = -20$  to  $+70^\circ\text{C}$  unless otherwise specified)

Parameter	Symbol	Condition	Min.	Typ.	Max.	Unit
SCLK Input Fall Time	$t_f$	—	—	—	1.0	$\mu\text{s}$
SCLK Input Rise Time	$t_r$	—	—	—	1.0	$\mu\text{s}$
SCLK Input "L" Level Pulse Width	$t_{CWL}$	—	0.8	—	—	$\mu\text{s}$
SCLK Input "H" Level Pulse Width	$t_{CWH}$	—	0.8	—	—	$\mu\text{s}$
SCLK Input Cycle Time	$t_{CYC}$	$V_{DDI} = 5$ V to $V_{DD}$	1.8	—	—	$\mu\text{s}$
SCLK Output Cycle Time	$t_{CYC1(0)}$	CPU in operation state at 32 kHz	—	30.5	—	$\mu\text{s}$
	$t_{CYC2(0)}$	CPU in operation at 2 MHz $V_{DD} = V_{DDH} = 2.7$ V to $5.5$ V	—	0.5	—	$\mu\text{s}$
SOUT Output Delay Time	$t_{DDR}$	Output load capacitance = 10 pF	—	—	0.4	$\mu\text{s}$
SIN Input Setup Time	$t_{DS}$	—	0.5	—	—	$\mu\text{s}$
SIN Input Hold Time	$t_{DH}$	—	0.8	—	—	$\mu\text{s}$

AC characteristics timing  
("H" level = 4.0 V, "L" level = 1.0 V)

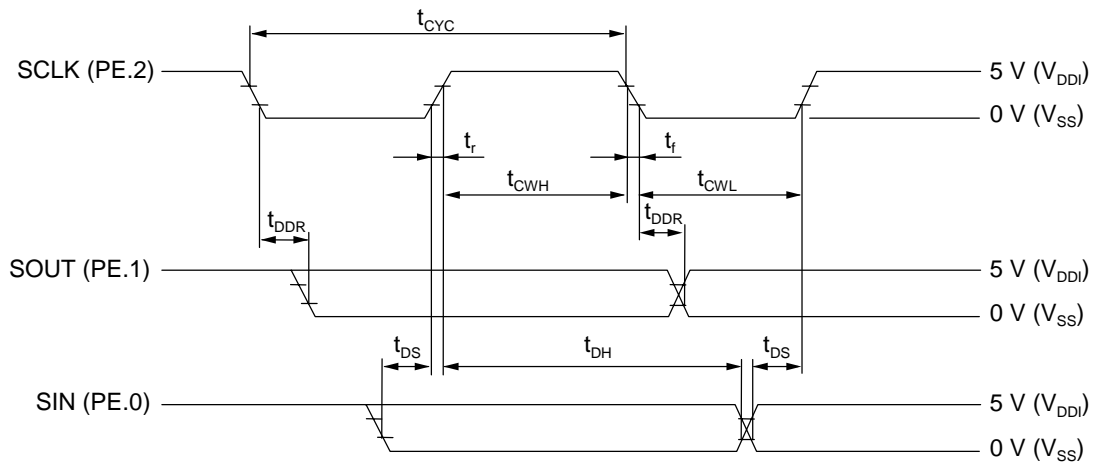

**AC Characteristics (External Memory Interface)**

( $V_{DD} = 0.9$  to  $5.5$  V,  $V_{DDH} = 1.8$  to  $5.5$  V,  $V_{SS} = 0$  V,  $V_{DDI} = 5.0$  V,  $T_a = -20$  to  $+70^\circ\text{C}$  unless otherwise specified)

(1) Reading from External Memory

(a) When CPU operates at 32.768 kHz

Parameter	Symbol	Condition	Min.	Typ.	Max.	Unit
Read Cycle Time	$t_{RC}$	—	—	61.0	—	$\mu\text{s}$
$\overline{\text{RD}}$ Output Delay Time	$t_{OE}$	—	—	—	5.0	$\mu\text{s}$
Output Valid Time	$t_{OHA}$	—	—	—	5.0	$\mu\text{s}$
External Memory Output Delay Time	$t_{DO}$	—	—	—	5.0	$\mu\text{s}$

(b) When CPU operates at 2 MHz ( $V_{DDH} = 2.7$  to  $5.5$  V)

Parameter	Symbol	Condition	Min.	Typ.	Max.	Unit
Read Cycle Time	$t_{RC}$	—	1.0	—	—	$\mu\text{s}$
$\overline{\text{RD}}$ Output Delay Time	$t_{OE}$	—	—	—	100	ns
Output Valid Time	$t_{OHA}$	—	—	—	100	ns
External Memory Output Delay Time	$t_{DO}$	—	—	—	150	ns

AC characteristics timing

("H" level = 4.0 V, "L" level = 1.0 V)

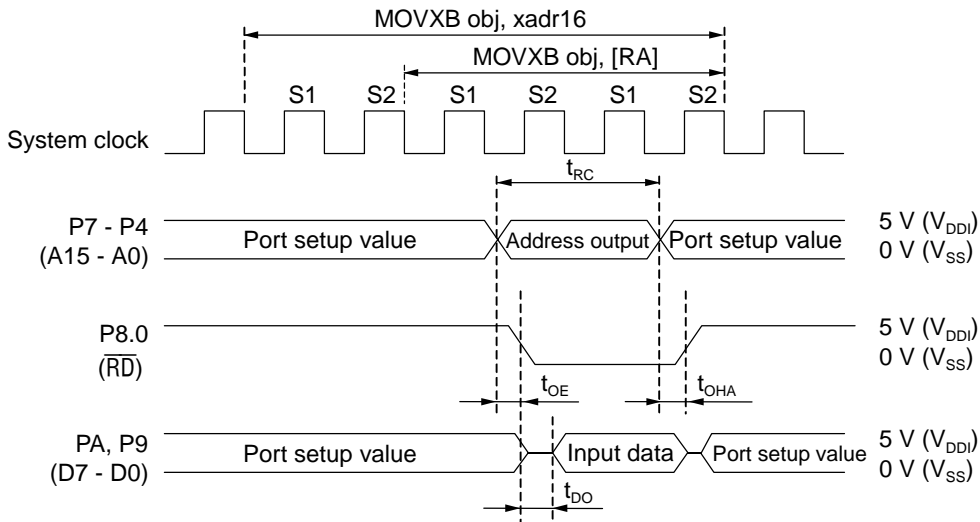

(2) Writing from External Memory

(a) When CPU operates at 32.768 kHz

Parameter	Symbol	Condition	Min.	Typ.	Max.	Unit
Write Cycle Time	$t_{WC}$	—	—	61.0	—	$\mu\text{s}$
Address Setup Time	$t_{AS}$	—	—	30.5	—	$\mu\text{s}$
Write Time	$t_W$	—	—	15.3	—	$\mu\text{s}$
Write Recovery Time	$t_{WR}$	—	—	15.3	—	$\mu\text{s}$
Data Setup Time	$t_{DS}$	—	—	45.8	—	$\mu\text{s}$
Data Hold Time	$t_{DH}$	—	—	15.3	—	$\mu\text{s}$

(b) When CPU operates at 2 MHz ( $V_{DDH} = 2.7$  to 5.5 V)

Parameter	Symbol	Condition	Min.	Typ.	Max.	Unit
Write Cycle Time	$t_{WC}$	—	1.0	—	—	$\mu\text{s}$
Address Setup Time	$t_{AS}$	—	0.4	—	—	$\mu\text{s}$
Write Time	$t_W$	—	0.2	—	—	$\mu\text{s}$
Write Recovery Time	$t_{WR}$	—	0.2	—	—	$\mu\text{s}$
Data Setup Time	$t_{DS}$	—	0.7	—	—	$\mu\text{s}$
Data Hold Time	$t_{DH}$	—	0.2	—	—	$\mu\text{s}$

AC characteristics timing

(“H” level = 4.0 V, “L” level = 1.0 V)

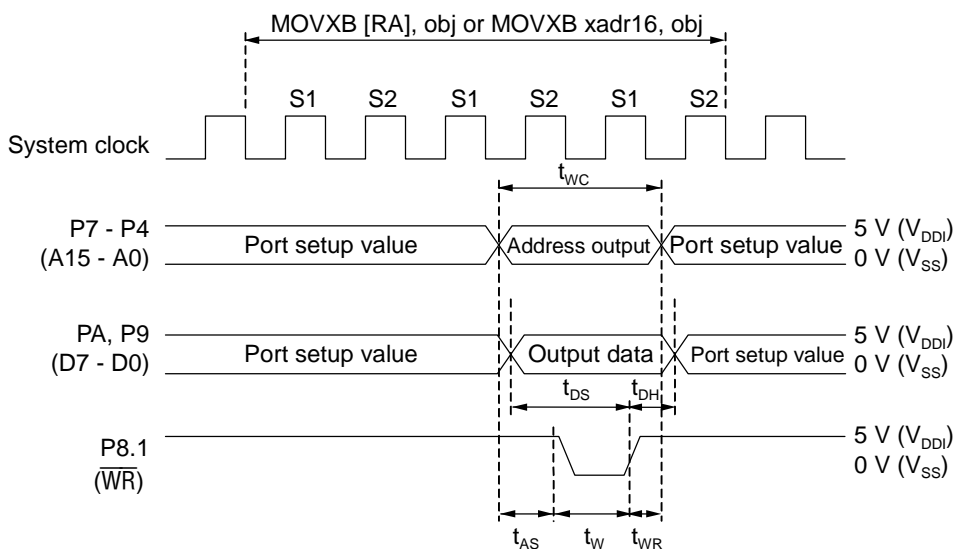

APPLICATION CIRCUITS

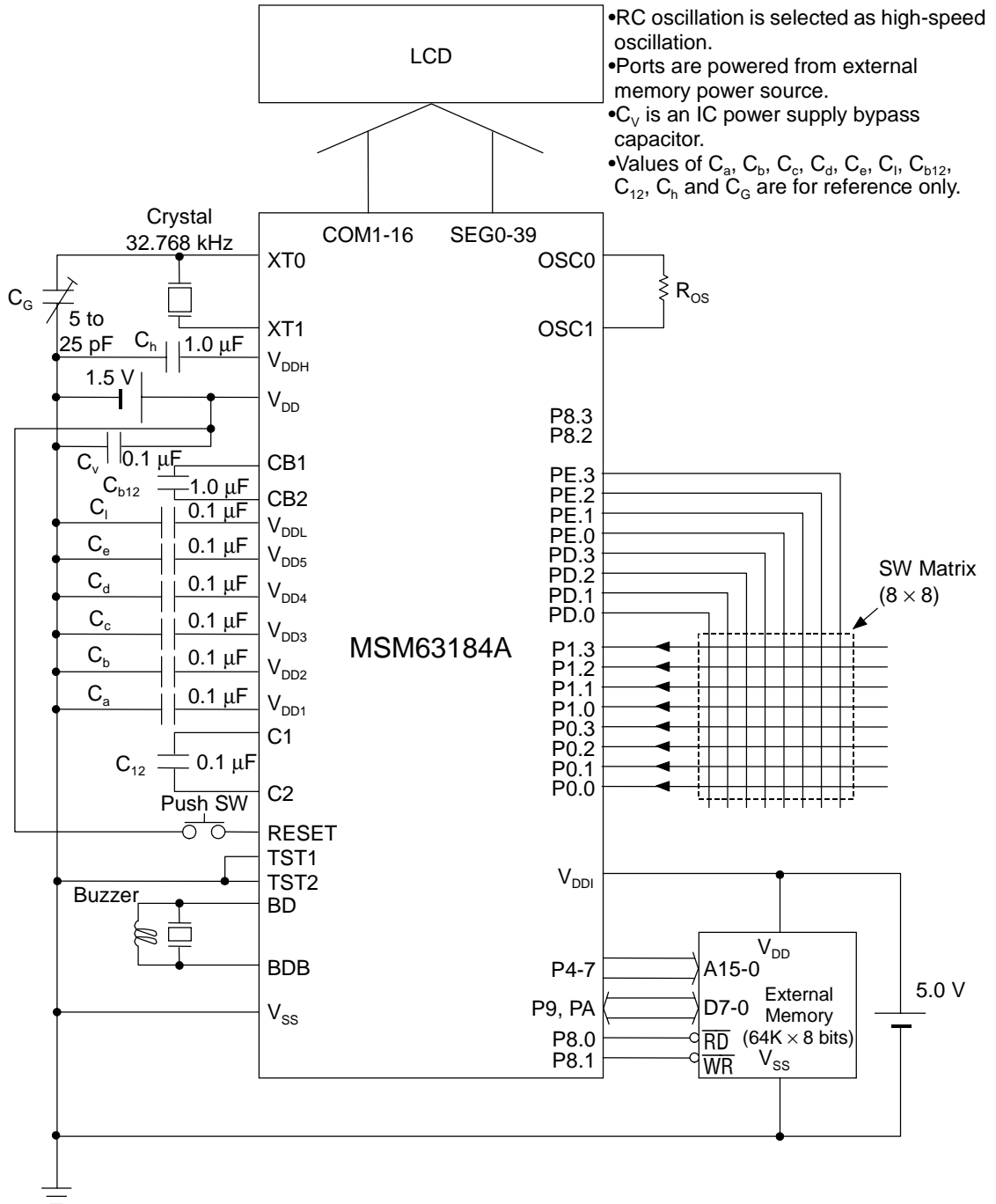

Note:  $V_{DDI}$  is the power supply pin for the input, output, and input-output ports. Be sure to connect the  $V_{DDI}$  pin either to the positive power supply pin ( $V_{DD}$ ) of this device or to the positive power supply pin of the external memory.

Application Circuit Example with Power Supply Backup

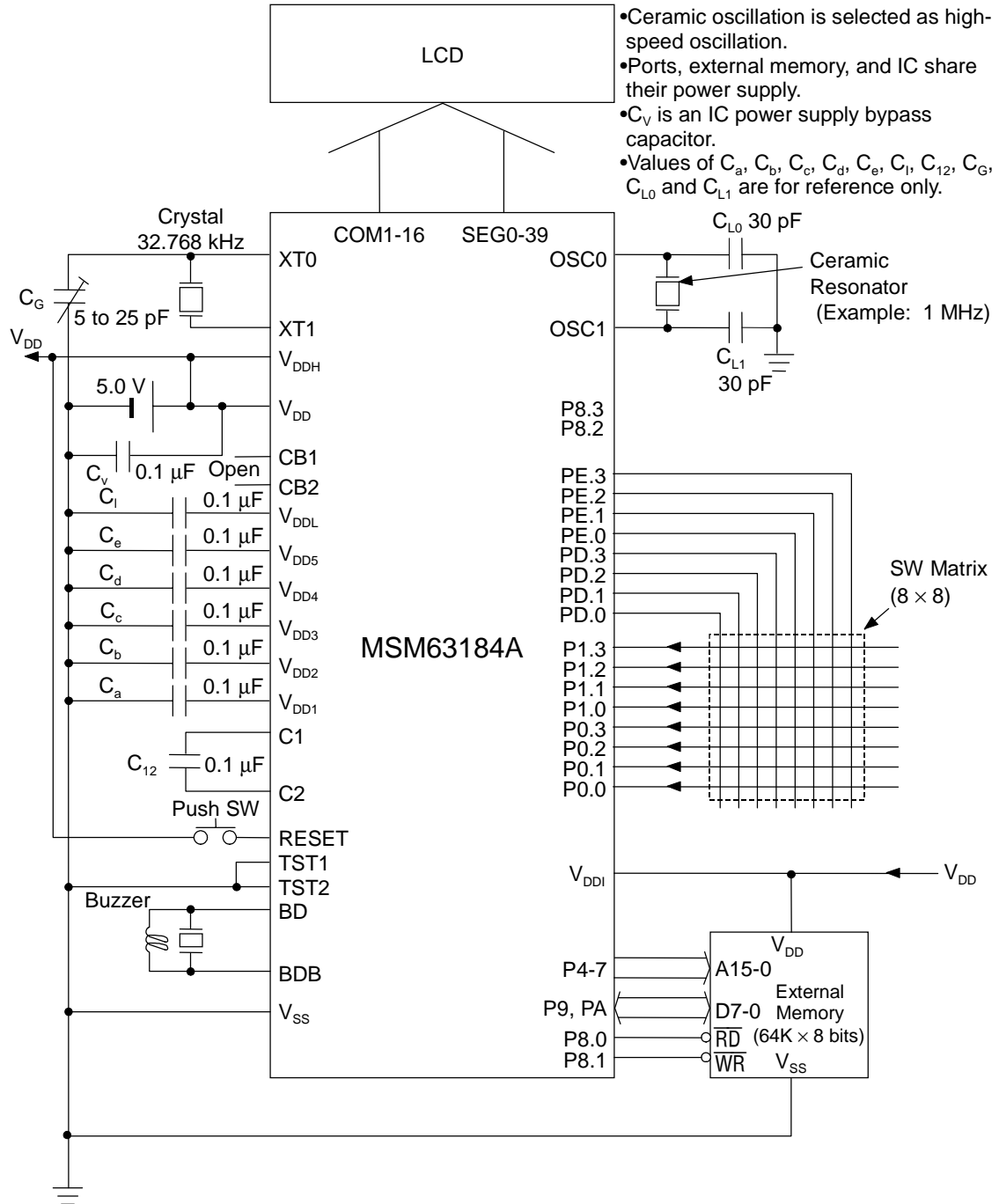

Note:  $V_{DDI}$  is the power supply pin for the input, output, and input-output ports. Be sure to connect the  $V_{DDI}$  pin either to the positive power supply pin ( $V_{DD}$ ) of this device or to the positive power supply pin of the external memory.

**Application Circuit Example with No Power Supply Backup**

**PACKAGE DIMENSIONS**

(Unit: mm)

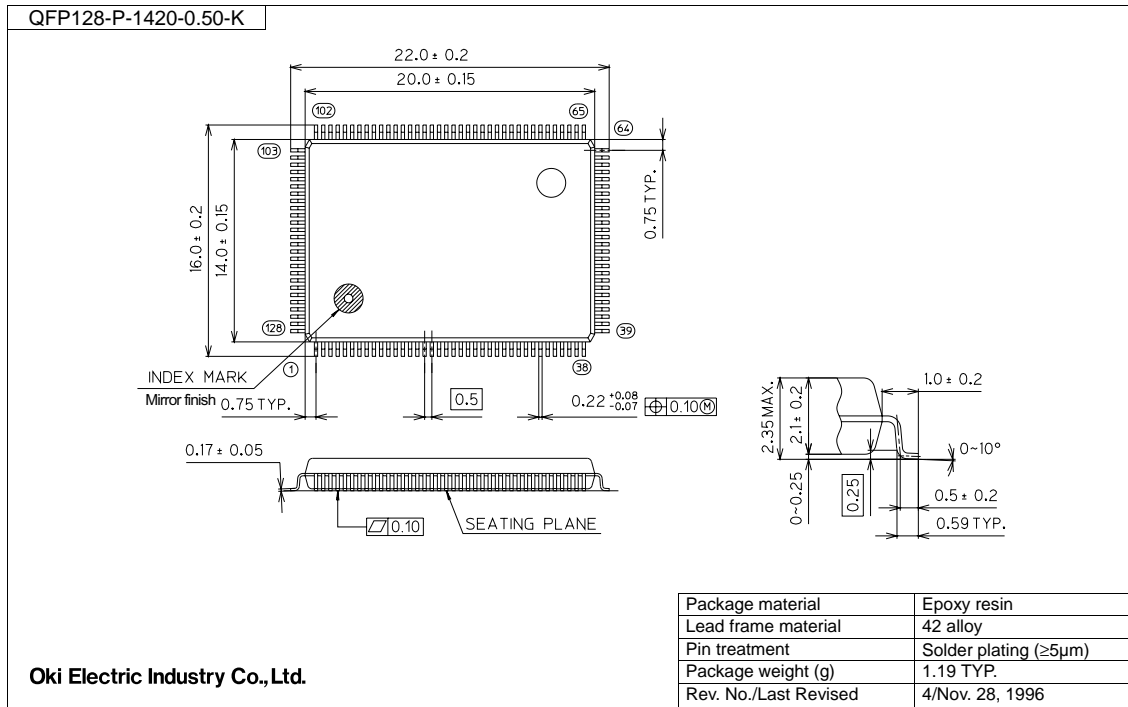

**Notes for Mounting the Surface Mount Type Package**

The surface mount type packages are very susceptible to heat in reflow mounting and humidity absorbed in storage.

Therefore, before you perform reflow mounting, contact Oki's responsible sales person for the product name, package name, pin number, package code and desired mounting conditions (reflow method, temperature and times).

**NOTICE**

1. The information contained herein can change without notice owing to product and/or technical improvements. Before using the product, please make sure that the information being referred to is up-to-date.
2. The outline of action and examples for application circuits described herein have been chosen as an explanation for the standard action and performance of the product. When planning to use the product, please ensure that the external conditions are reflected in the actual circuit, assembly, and program designs.
3. When designing your product, please use our product below the specified maximum ratings and within the specified operating ranges including, but not limited to, operating voltage, power dissipation, and operating temperature.
4. Oki assumes no responsibility or liability whatsoever for any failure or unusual or unexpected operation resulting from misuse, neglect, improper installation, repair, alteration or accident, improper handling, or unusual physical or electrical stress including, but not limited to, exposure to parameters beyond the specified maximum ratings or operation outside the specified operating range.
5. Neither indemnity against nor license of a third party's industrial and intellectual property right, etc. is granted by us in connection with the use of the product and/or the information and drawings contained herein. No responsibility is assumed by us for any infringement of a third party's right which may result from the use thereof.
6. The products listed in this document are intended for use in general electronics equipment for commercial applications (e.g., office automation, communication equipment, measurement equipment, consumer electronics, etc.). These products are not authorized for use in any system or application that requires special or enhanced quality and reliability characteristics nor in any system or application where the failure of such system or application may result in the loss or damage of property, or death or injury to humans. Such applications include, but are not limited to, traffic and automotive equipment, safety devices, aerospace equipment, nuclear power control, medical equipment, and life-support systems.
7. Certain products in this document may need government approval before they can be exported to particular countries. The purchaser assumes the responsibility of determining the legality of export of these products and will take appropriate and necessary steps at their own expense for these.
8. No part of the contents contained herein may be reprinted or reproduced without our prior permission.

Copyright 2001 Oki Electric Industry Co., Ltd.