

Model 45

Fatigue Rated Universal Load Cell



DESCRIPTION

Model 45 Ultra Precision Fatigue-Rated Load Cell offers a low profile design for both tension and compression applications. The all-welded stainless steel construction and stabilizing diaphragms provide the same ruggedness which has made our Model 41 and 43 pancake type load cells so successful. The

Model 45 is available in ranges 250 lb through 100,000 lb. and mounting dimensions are universally interchangeable within the test and measurement industry. Options include hi-level outputs of 4 mA to 20 mA or 0 Vdc to 5 Vdc as well as weatherproof or submersible cable configurations.

FEATURES

- Up to 0.04 % accuracy (see specification table for specific range)
- 250 lb to 100000 lb
- Long fatigue life
- Intrinsically safe available (2N option only)¹²
- CE approved¹³

Model 45

PERFORMANCE SPECIFICATIONS

Characteristic	Measure		
Load ranges ¹⁴	250 lb to 100000 lb		
	Accuracy (static error band) ^{1,2}	Linearity	Hysteresis
250 lb to 1000 lb	±0.04 % full scale	±0.04 % full scale	±0.03 % full scale
2500 lb to 50000 lb	±0.05 % full scale	±0.05 % full scale	±0.05 % full scale
100000 lb	±0.06 % full scale	±0.05 % full scale	±0.05 % full scale
Non-repeatability	±0.02 % full scale		
Output	2 mV/V		
Tolerance on output	±1 % full scale		
Creep in 20 min. (max.)	0.01 %		

ENVIRONMENTAL SPECIFICATIONS

Characteristic	Measure
Temperature, operating	-54 °C to 93 °C [-65 °F to 200 °F]
Temperature, compensated	-1 °C to 54 °C [30 °F to 130 °F]
Temperature effect, zero	0.0008 % full scale/°F
Temperature effect, span	0.0008 % reading/°F

ELECTRICAL SPECIFICATIONS

Characteristic	Measure
Strain gage type	Foil
Excitation (calibration)	10 Vdc
Excitation (acceptable)	20 Vdc
Insulation resistance	5000 mOhm @ 50 V
Bridge resistance (tolerance)	350 ohm (nominal) ⁸
Zero balance (tolerance)	±1 % full scale
Shunt calibration data	Included
Electrical termination (std)	PC02A-10-6P
Mating connector (not included)	PC06A-10-6S

MECHANICAL SPECIFICATIONS

Characteristic	Measure
Maximum allowable load	200 % FS ^{3,9}
Weight	See table
Case material	Stainless steel
Life cycles (approx.)	> 10 ⁸ cycles fully reversed
Deflection	See table
Natural frequency	See table

RANGE CODES

Range Code	Available ranges	Range Code	Available ranges
CN	250 lb	DW	12500 lb
CR	500 lb	EM	25000 lb
CV	1000 lb	EP	50000 lb
DM	2500 lb	ET	100000 lb
DR	5000 lb		

BASE PLATE ORDER INFORMATION

Ranges	Base plate order code	Base plate weight kg [lb]	Load button order code
250 lb to 1000 lb	AA229	1,59 [3.5]	AA290
2500 lb to 5000 lb	AA229	1,59 [3.5]	AA290
12500 lb to 25000 lb	AA230	4,99 [11]	AA291
50000 lb	AA231	9,07 [20]	AA292
100000 lb	AA232	27,67 [61]	AA293

WIRING CODES

Connector	Unamplified
A	(+) excitation
B	(+) output
C	(-) output
D	(-) excitation
E	no connection
F	no connection

DEFLECTIONS AND RINGING FREQUENCIES

Capacity (lb)	Deflection @ full scale (10 ⁻³ in)	Natural ringing frequency (Hz)	Weight g [lb]
250	1.5	2400	1406,1 [3.1]
500	1.5	2400	1406,1 [3.1]
1000	1.5	3400	1406,1 [3.1]
2500	1	6800	1451,5 [3.2]
5000	1	9100	1451,5 [3.2]
12500	2	5700	3994,6 [8.8]
25000	2	7000	3994,6 [8.8]
50000	2	6300	9979 [22]
100000	2.5	4500	24947,58 [55]

Fatigue Rated Universal Load Cell

INTERNAL AMPLIFIERS

Amplifier specifications	Voltage output: Option 2b	Voltage output: Option 2c	Voltage output: Option 2t	Current three-wire: Option 2j	Current two-wire: Option 2k	Intrinsically safe amp: Option 2n (2N)***
Output signal	±5 V	0 V to 5 V or ±5 V @ 45 mA	0 V to 10 V or ±10 V @ 45 mA	4 mA to 20 mA	4 mA to 20 mA	4 mA to 20 mA
Input power (voltage)	±15 V or 26 Vdc to 32 Vdc	11 Vdc to 28 Vdc	15 Vdc to 28 Vdc	22 Vdc to 32 Vdc	15 Vdc to 40 Vdc	9 Vdc to 28 Vdc
Input power (current)	45 mA	40 mA	40 mA	65 mA	4 mA to 28 mA	4 mA to 24 mA
Freq. resp (amp)	3000 Hz	3000 Hz	3000 Hz	2500 Hz	300 Hz	2000 Hz
Power supply rej.	60 db	60 db	60 db	60 db	60 db	60 db
Operating temp.	-20 °F to 185 °F	-20 °F to 185 °F	-20 °F to 185 °F	0 °F to 185 °F	0 °F to 185 °F	-20 °F to 185 °F
Reverse voltage protection	Yes	Yes	Yes	Yes	Yes	Yes
Short cir. protection	Momentary	Momentary	Momentary	Yes	Yes	Yes
Wiring code: connector (std)⁵	A (+) Supply B Output common C Supply return D (+) Output E Shunt cal 1 F Shunt cal 2	A (+) Supply B Output common** C Supply return ** D (+) Output E Shunt cal 1 F Shunt cal 2	A (+) Supply B Output common** C Supply return** D (+) Output E Shunt cal 1 F Shunt cal 2	A (+) Supply B Output common** C Supply return** D (+) Output E Shunt cal 1 F Shunt cal 2	A (+) Supply B No connection C No connection D (+) Output E Case ground F No connection	A (+) Supply B No connection C No connection D (+) Output E Case ground F No connection
Wiring code: cable^{5,6,7}	R (+) Supply BI Output common G Supply return W (+) Output B Shunt cal 1 Br Shunt cal 2	R (+) Supply BI Output common* G Supply return* W (+) Output B Shunt cal 1 Br Shunt cal 2	R (+) Supply BI Output common* G Supply return* W (+) Output B Shunt cal 1 Br Shunt cal 2	R (+) Supply BI Output common* G Supply return* W (+) Output B Shunt cal 1 Br Shunt cal 2	R (+) Supply BI (+) Output W Case ground	R (+) Supply BI (+) Output W Case ground

* Black and green wires are internally connected.

** Pins B and C are internally connected.

*** See our Web site for the most up-to-date information regarding intrinsically safe approvals, ref. #008-0547-00.

TYPICAL SYSTEM DIAGRAM

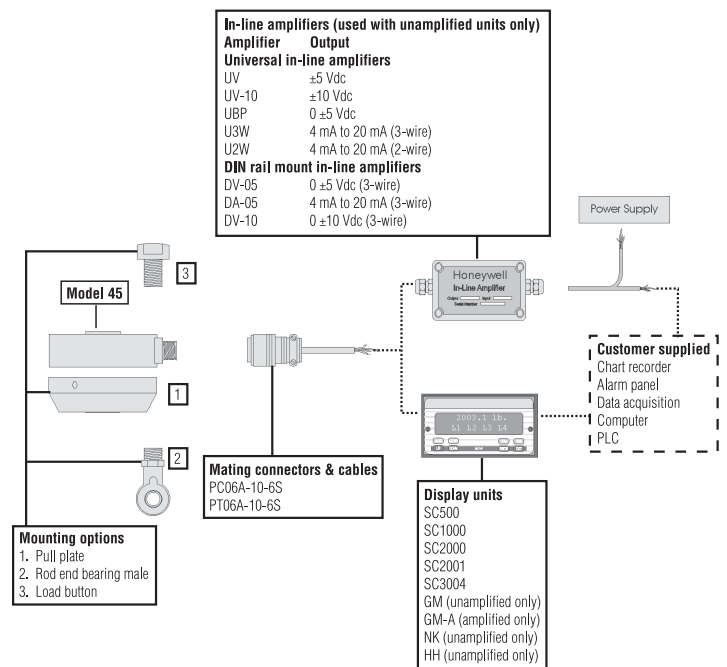

Model 45

OPTION CODES

	Many range/option combinations are available in our quick-ship and fast-track manufacture programs. Please see http://sensing.honeywell.com/TMsensor-ship for updated listings.	
Load ranges	250, 500, 1000, 2500, 5000, 12500, 25000, 50000, 100000 lb	
Temperature compensation	1a. 60 °F to 160 °F 1b. 30 °F to 130 °F 1c. 0 °F to 185 °F 1d. -20 °F to 130 °F 1e. -20 °F to 200 °F 1f. 70 °F to 250 °F	1g. 70 °F to 325 °F ¹⁶ 1h. 70 °F to 400 °F ¹⁶ 1i. -65 °F to 250 °F ¹⁶ 1j. 0 °C to 50 °C 1k. -20 °C to 85 °C 1m. -25 °C to 110 °C
Internal amplifiers	2b. ±5 Vdc output 2c. 0 Vdc to 5 Vdc 2j. 4 mA to 20 mA (three-wire) output 2k. 4 mA to 20 mA (two-wire) ¹⁵	2n (2N) 4 mA to 20 mA (two-wire) intrinsically safe ¹⁵ 2t. 0 Vdc to 10 Vdc output 2u. Unamplified, mV/V output
Internal amplifier enhancements	3d. Remote buffered shunt calibration	
Electrical termination	PC02A-10-6P 6a. Bendix PTIH-10-6P (or equivalent), 6-pin (max. 250 °F) 6b. MS connector MS3102E-14S-6P (mates with MS3106E-14S-6S) (max. 160 °F) ¹⁷	
Shunt calibration	8a. Precision internal resistor ¹⁶	
Special calibration	9c. ASTM E-74 calibration 30a. Compression only calibration, positive in compression 30b. Tension and compression calibration, positive in tension 30c. Compression only calibration, negative in compression 30d. Tension and compression calibration, positive in compression	
Bridge type	31a. Dual bridge 11c. Square and symmetrical bridge ¹⁶	
Electrical connector orientation	15a. Horizontal electrical exit port orientation	
Shock and vibration	44a. Shock and vibration resistance	
Interfaces	53e. Signature calibration ¹⁶ 53t. TEDS IEEE 1451.4 module ¹¹	

Fatigue Rated Universal Load Cell

MOUNTING DIMENSIONS

LOAD CELL Ranges lb	Ø D1 mm [in]	H mm [in]	T	ØB mm [in]	N mm [in]	F1
250, 500, 1000, 2500, 5000	104,65 [4.12]	34,8 [1.37]	5/8-18 UNF-3B	34,0 [1.34]	3,05 [0.12]	9/32 in dia., 8 holes eq. sp., 3.50 B.C.
12500, 25000	153,92 [6.06]	44,45 [1.75]	1 1/4-12 UNF-3B	67,31 [2.65]	3,05 [0.12]	13/32 in dia., 12 holes eq. sp., 5.125 B.C.
50000	203,2 [8.00]	63,5 [2.50]	1 3/4-12 UNF-3B	95,50 [3.76]	6,35 [0.25]	17/32 in dia., 16 holes eq. sp., 6.50 B.C.
100000	279,4 [11.00]	88,9 [3.50]	2 3/4-8 UNF-3B	122,17 [4.81]	12,7 [0.50]	11/16 in dia., 16 holes eq. sp., 9.00 B.C.

PULL PLATE Ranges lb	Order code	ØD2 mm [in]	L mm [in]	T	ØG mm [in]	F2
250, 500, 1000, 2500, 5000	AA229	104,65 [4.12]	28,45 [1.12]	5/8-18 UNF-3B	31,75 [1.25]	1/4-28, 8 holes eq. sp., 3.50 B.C.
12500, 25000	AA230	153,92 [6.06]	44,45 [1.75]	1 1/4-12 UNF-3B	57,15 [2.25]	3/8-24, 12 holes eq. sp., 5.125 B.C.
50000	AA231	203,2 [8.00]	50,8 [2.00]	1 3/4-12 UNF-3B	76,2 [3.00]	1/2-20, 16 holes eq. sp., 6.50 B.C.
100000	AA232	279,4 [11.00]	76,2 [3.00]	2 3/4-8 UNF-3B	114,3 [4.50]	5/8-18, 16 holes eq. sp., 9.00 B.C.

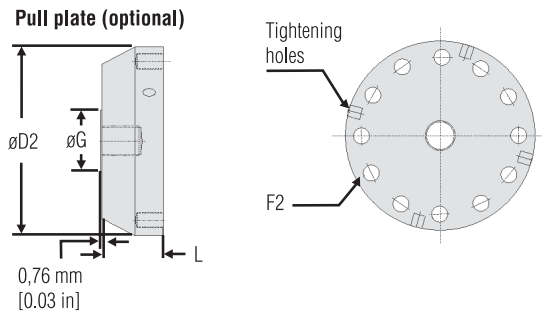
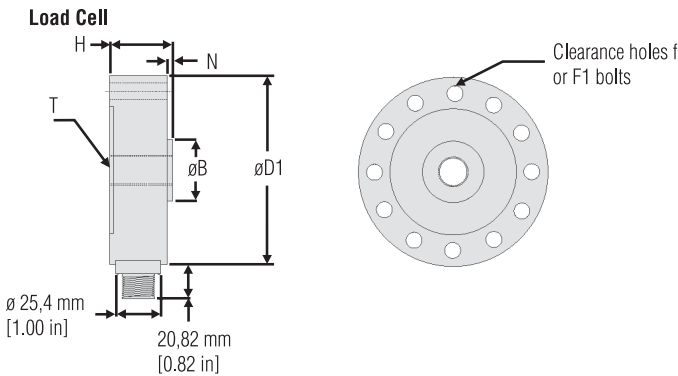

NOTES

1. Static error band is the recommended performance specification. The static error band is calculated as the best fit straight line through zero, including the effects of non-linearity, hysteresis and non-repeatability.
2. Values noted are typical values but fall within the static error.
3. Allowable maximum loads – maximum load to be applied without damage.⁴
4. Without damage - loading to this level will not cause excessive zero shift or performance degradation. The user must consider fatigue life for long term use and structural integrity. All structurally critical applications (overhead loading, etc.) should always be designed with safety redundant load paths.
5. Interconnecting shunt cal. 1 terminal with shunt cal. 2 terminal provides 50 % (unamplified units), 75 % (4 mA to 20 mA three-wire units) or 80 % (voltage amplified units) of full scale output for quick calibration. Shunt calibration comes standard with internal amplifier option 2c, 2t and 2j.
6. O=Orange; Y=Yellow; B=Blue; Bl=Black; R=Red; Br=Brown; W=White; G=Green. Color specifying cable and number or letter specifying connector.
7. No mating connector necessary for cable option.
8. 250 lb. range has 700 ohm bridge resistance.
9. Off axis loading maximum allowable 50 % full scale.
10. Internal amplifier for ranges less than 12,500 lb may increase in height.
11. Consult factory for TEDS availability with amplified models.
12. Range dependent; consult factory. Termination dependent; consult factory.
13. Internal amp and termination dependent; consult factory.
14. This unit calibrated to Imperial (non-Metric) units.
15. 5000 ohm bridge required.
16. Cannot be used with amplified option.
17. Cannot be used with options 1c, 1e, 1f, 1g, 1h, or 1i.

Warranty. Honeywell warrants goods of its manufacture as being free of defective materials and faulty workmanship. Honeywell's standard product warranty applies unless agreed to otherwise by Honeywell in writing; please refer to your order acknowledgement or consult your local sales office for specific warranty details. If warranted goods are returned to Honeywell during the period of coverage, Honeywell will repair or replace, at its option, without charge those items it finds defective. **The foregoing is buyer's sole remedy and is in lieu of all warranties, expressed or implied, including those of merchantability and fitness for a particular purpose. In no event shall Honeywell be liable for consequential, special, or indirect damages.**

While we provide application assistance personally, through our literature and the Honeywell web site, it is up to the customer to determine the suitability of the product in the application.

Specifications may change without notice. The information we supply is believed to be accurate and reliable as of this printing. However, we assume no responsibility for its use.

For more information about Sensing and Control products, visit www.honeywell.com/sensing or call +1-815-235-6847

Email inquiries to info.sc@honeywell.com

⚠ WARNING
PERSONAL INJURY

- DO NOT USE these products as safety or emergency stop devices or in any other application where failure of the product could result in personal injury.

Failure to comply with these instructions could result in death or serious injury.

⚠ WARNING
MISUSE OF DOCUMENTATION

- The information presented in this catalogue is for reference only. DO NOT USE this document as product installation information.
- Complete installation, operation and maintenance information is provided in the instructions supplied with each product.

Failure to comply with these instructions could result in death or serious injury.

Sensing and Control
Automation and Control Solutions
Honeywell
1985 Douglas Drive North
Golden Valley, MN 55422 USA
+1-815-235-6847

www.honeywell.com/sensing

SUNSTAR自动化 <http://www.sensor-ic.com/> TEL: 0755-83376489 FAX:0755-83376182 E-MAIL:szss20@163.com

008612-1-EN IL50 GLO
May 2008

Copyright © 2008 Honeywell International Inc. All rights reserved.

Honeywell