

Features and Benefits

- Programmable high speed Hall sensor
- Wide bandwidth, short response time 8μs
- Programmable linear transfer characteristic
- Selectable analog ratiometric output
- Measurement range from ±15mT to ±400mT
- Thermometer output
- 17 bit ID number
- Single die SOIC8 package RoHS compliant
- Lead free component, suitable for lead free soldering profile 260 °C
- Low thermal Drift (Gain and Offset)

Application Examples

- Current sensor applications
 - Over current detection circuit
 - Inverter Application HEV &EV
 - AC/DC converters
 - Battery management
- Position sensor application

Ordering Code

Product Code	Temperature Code	Package Code	Ordering Option Code	Packing form Code	Comment
MLX91207	L (-40°C to 150°C)	DC (SOIC)	CAA-005	TU (Tube)	15-45mV/mT (25mV/mT)
MLX91207	L (-40°C to 150°C)	DC (SOIC)	CAA-005	RE (Reel)	15-45mV/mT (25mV/mT)
MLX91207	L (-40°C to 150°C)	DC (SOIC)	CAA-007	TU	5-20mV/mT (10mV/mT)
MLX91207	L (-40°C to 150°C)	DC (SOIC)	CAA-007	RE	5-20mV/mT (10mV/mT)
MLX91207	L (-40°C to 150°C)	DC (SOIC)	CAA-015 ⁽¹⁾	TU	15-45mV/mT (25mV/mT)
MLX91207	L (-40°C to 150°C)	DC (SOIC)	CAA-015 ⁽¹⁾	RE	15-45mV/mT (25mV/mT)

(1) Ratiometry is disabled by default for this version

Ordering example : MLX91207-LDC-CAA-007-TU

1 Functional Diagram

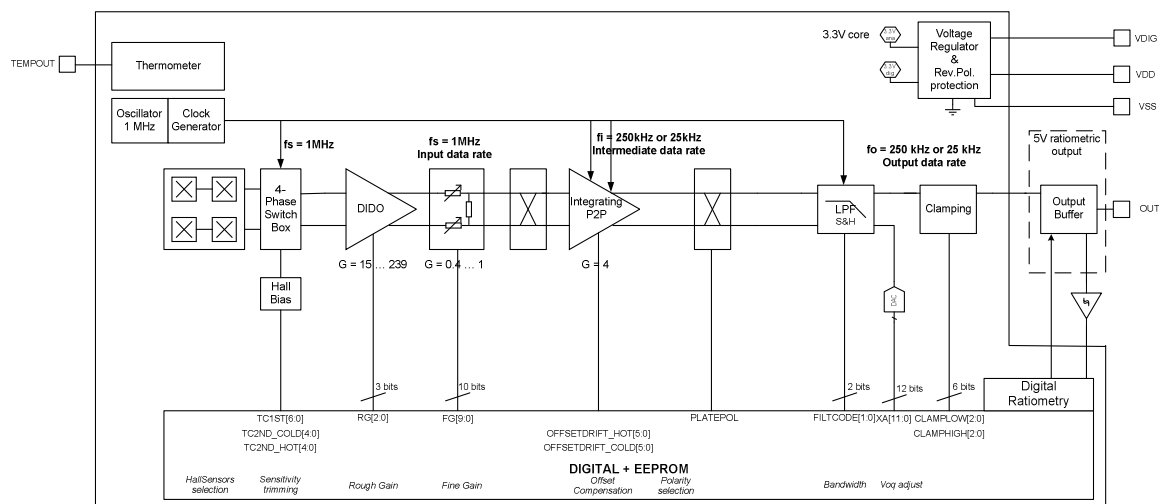

Figure 1: Block diagram

2 General Description

The MLX91207 is a monolithic programmable Hall sensor IC, which provides a high speed analog output signal proportional to the external applied flux density. The sensor is ideally suitable for current sensing applications and features an additional thermometer output. Moreover, the sensor can be integrated in position sensing applications where fast response time is required.

The transfer characteristics of the MLX91207 are fully programmable (offset, gain, clamping levels, diagnostic functions). The full analog chain features a fast response time and allows use of the sensor for applications where a very fast response time < 10 μ sec is required.

In the typical application the sensor is used in combination with a ring shaped soft ferromagnetic core. The Hall-IC is placed in a small air gap and the current conductor is passed through the inner part of the ferromagnetic ring. The ferromagnetic ring concentrates and amplifies the magnetic flux on the Hall-Sensor IC which generates an output voltage proportional to the current. Figure 2 shows a typical sensor application for a contact-less current measurement.

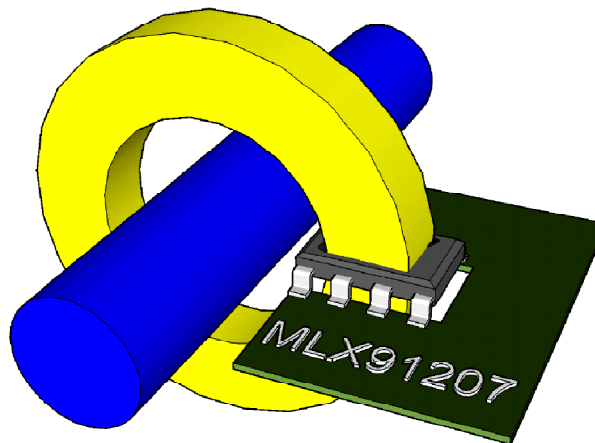

Figure 2: Typical application of MLX91207



3 Table of Contents

1 Functional Diagram.....	1
2 General Description.....	2
3 Table of Contents	3
4 Glossary of Terms	4
5 Absolute Maximum Ratings	4
6 Pin Definitions and Descriptions	4
7 General Electrical Specifications.....	5
8 Magnetic specification	6
9 Output specification	6
9.1 Timing specification.....	6
9.2 Accuracy Specification	7
9.3 Remarks to the achievable accuracy	7
10 Thermometer Output	7
11 Programmable Items	8
11.1 Customer Parameter Table	8
11.2 Description of Programmable Items.....	9
11.2.1 Output Mode Configuration (OUTMODE).....	9
11.2.2 Output impedance mode (DIAGINFALT)	9
11.2.3 Sensitivity Programming (ROUGHGAIN and FINEGAIN)	9
11.2.4 Offset Compensation VOQ (XA).....	9
11.2.5 Sensitivity polarity (PLATEPOL).....	10
11.2.6 Clamping Level Programming (CLAMPLOW, CLAMPHIGH).....	10
11.2.7 Bandwidth and Filter Programming (FILTER).....	11
11.2.8 Power Limitation (OUTSLOPE).....	11
11.2.9 Output Ratiometry (RATIODIS).....	12
11.2.10 Sensitivity Temperature Drift Programming (TC1ST, TC2ND_COLD, TC2ND_HOT)	12
11.2.11 Offset Temperature Drift Programming (OFFDRIFT_COLD, OFFDRIFT_HOT).....	12
11.2.12 Product Identification (MLXID, CSTID)	13
12 Self Diagnostic.....	14
13 Applications Information.....	15
13.1 Current Measurement.....	15
13.2 Linear Position.....	15
14 Recommended Application Diagrams	16
14.1 Resistor and Capacitor Values	16
14.2 Pull down resistor for diagnostic low	16
14.3 Pull up resistor for diagnostic high	16
15 Standard information regarding manufacturability of Melexis products with different soldering processes	17
16 ESD Precautions	17
17 Package Information.....	18
17.1 SOIC8 Package Dimensions	18
17.2 SOIC8 Pin Out and Marking	19
18 Related documents and tools.....	20
18.1 Related documents	20
18.2 Related software	20
18.3 Related hardware	20
19 Disclaimer.....	21



MLX91207

High Speed Hall Sensor IC

4 Glossary of Terms

Tesla	Units for the magnetic flux density, 1 mT = 10 Gauss
TC	Temperature Coefficient in ppm/deg C
NC	Not Connected
ADC	Analog-to-Digital Converter
DAC	Digital-to-Analog Converter
LSB	Least Significant Bit
MSB	Most Significant Bit
DNL	Differential Non Linearity
INL	Integral Non Linearity
ASP	Analog Signal Processing
DSP	Digital Signal Processing
PTC	Programming Through Connector

5 Absolute Maximum Ratings

Parameter	Symbol	Value	Units
Positive Supply Voltage (overvoltage)	V _{dd}	+20	V
Reverse Supply Voltage Protection		-10	V
Positive Output Voltage		+10 +14 (200 s max, T _A = +25 °C)	V
Output Current	I _{out}	±300	mA
Reverse Output Voltage		-0.3	V
Reverse Output Current		-50	mA
Operating Ambient Temperature Range	T _A	-40 to +125	°C
Storage Temperature Range	T _S	-55 to +150	°C
Magnetic Flux Density		± 2	T

Table 1: Absolute maximum ratings

Exceeding the absolute maximum ratings may cause permanent damage. Exposure to absolute maximum rated conditions for extended periods may affect device reliability.

6 Pin Definitions and Descriptions

Pin №	Name	Type	Function
1	VDD	Supply	Supply Voltage
2	VSS	Ground	Supply Voltage
3	VDIG	Supply	Digital supply voltage, 3.3 V, internal regulated
4	MUST1	Digital	Test pin
5	OUT	Analog	Sensor output signal
6	TESTOUT	Digital	Test pin
7	MUST0	Digital	Test pin
8	TEMPOUT	Analog	Temperature sensor output

Table 2: Pin definition and description

It is recommended to connect the unused pins to Ground (see section 14) for optimal EMC results.

7 General Electrical Specifications

Operating Parameters $T_A = -40^{\circ}\text{C}$ to 125°C , $V_{dd} = 5.0\text{ V}$, $I_{out} = +/-2\text{mA}$, recommended application diagram in section 14 used, unless otherwise specified.

Parameter	Symbol	Test Conditions	Min	Typ	Max	Units
Nominal Supply Voltage	V_{dd}		4.5	5	5.5	V
Supply Current	I_{dd}	Without output load $T_A = -40^{\circ}\text{C}$ to 150°C		9	12	mA
Output Current	I_{out}		-2		2	mA
Output Resistance		$V_{out} = 50\% V_{dd}$, $R_L = 5\text{k}\Omega$		1	5	Ω
Output Capacitive Load	C_{load}		5	10	50	nF
Output Short Circuit Current	I_{short}	Output shorted to V_{dd} - Permanent Output shorted to V_{ss} - Permanent	Not Destroyed			
Leakage current	I_{leak}	High impedance mode ⁽¹⁾			5	μA
Output Voltage Swing (Linear Range)	V_{out_pd}	pull down $\geq 10\text{ k}\Omega$	5		95	%Vdd
	V_{out_pu}	pull up $\geq 10\text{ k}\Omega$	5		95	%Vdd
High-impedance mode levels ⁽¹⁾	$V_{out_HiZ_pu}$	pull-up $R_L \leq 30\text{ k}\Omega$	97			%Vdd
	$V_{out_HiZ_pd}$	pull-down $R_L \leq 30\text{ k}\Omega$			3	%Vdd
BrokenVss Output Levels ⁽¹⁾	OUT with pull-down $R_L \leq 10\text{ k}\Omega$				3	%Vdd
	OUT with pull-up $R_L \leq 30\text{ k}\Omega$ ⁽²⁾		97			%Vdd
BrokenVdd Output Levels ⁽¹⁾	OUT with pull-down $R_L \leq 30\text{ k}\Omega$ ⁽²⁾				3	%Vdd
	OUT with pull-up $R_L \leq 30\text{ k}\Omega$ ⁽²⁾		97			%Vdd
Under-voltage detection ^{(1) (4)}	V_{dd_uvd}	Detected Voltage (L to H)	3.15	3.3	3.45	V
	V_{dd_uvh}	Hysteresis	0.25	0.3	0.4	V
Over-voltage detection mode 1 ^{(1) (4)}	V_{dd_ovd1}	Detected Voltage (L to H)	7.9		9.5	V
	V_{dd_ovh1}	Hysteresis	0.8		1.6	V
Over-voltage detection mode 2 ^{(1) (4)}	V_{dd_ovd2}	Detected Voltage (L to H)	6.7		7.6	V
	V_{dd_ovh2}	Hysteresis	0.05		0.5	V
Clamped Output Level	Clamp_lo	Trimming Range	5 ⁽³⁾		10	%Vdd
	Clamp_hi	Trimming Range	90		95 ⁽³⁾	%Vdd

Table 3: General electrical parameters

- (1) Refer to chapter 13 Self-diagnostic, table 15.
- (2) Valid for TEMPOUT with pull-up (min. 30k Ω), pull-down (min. 30k Ω) or not connected
- (3) Factory programmed clamping level
- (4) According to the figure below

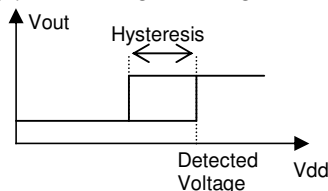

Figure 3: Detected voltage and hysteresis definitions



MLX91207

High Speed Hall Sensor IC

8 Magnetic specification

Operating Parameters $T_A = -40^{\circ}\text{C}$ to 125°C , $V_{DD} = 5.0\text{ V}$, unless otherwise specified.

Parameter	Symbol	Test Conditions	Min	Typ	Max	Units
Magnetic field range	B		± 15	± 45	± 450	mT
Linearity Error	NL	$B = \pm 45\text{ mT}$ ($T_A = 25^{\circ}\text{C}$)		0.1	0.25	$\pm\%FS^{(1)}$
Programmable Sensitivity	S		15 ⁽²⁾	25 ⁽²⁾	40 ⁽²⁾	mV/mT
			5 ⁽³⁾	10 ⁽³⁾	20 ⁽³⁾	mVm/T
Sensitivity programming Resolution	Sres			0.1		%

Table 4: Magnetic specification

- (1) By design
- (2) MLX91207LDC-CAA-005 / MLX91207LDC-CAA-015
- (3) MLX91207LDC-CAA-007

9 Output specification

9.1 Timing specification

Operating Parameters $T_A = -40^{\circ}\text{C}$ to 125°C , $V_{DD} = 5.0\text{ V}$, unless otherwise specified

Parameter	Symbol	Test Conditions	Min	Typ	Max	Units
Step Response Time ⁽¹⁾	Tresp	$V_{Oq} \pm 2\text{ V}$		8	10	μs
Bandwidth	BW	Full Range (referenced to externally applied field)		60		kHz
Power on Delay	T _{POD}	V _{out} = 100% of FS (BW = 100 Hz) (BW = 1000 Hz) (BW = 10 kHz) (BW = 60 kHz – No filter)			100	ms
					10	ms
			0.35			ms
			0.25			ms
Ratiometry Cut-off Frequency	Fratio			250		Hz

Table 5: Timing specification of the analog output

- (1) Time interval between when the applied magnetic field reaches 90% of its maximum value and when the sensor's output reaches 90% corresponding to this magnetic field



MLX91207

High Speed Hall Sensor IC

9.2 Accuracy Specification

Operating Parameters $T_A = -40^{\circ}\text{C}$ to 125°C , $V_{dd} = 5.0\text{ V}$, $S = 50\text{ mV/mT}$, unless otherwise specified. Specifications are defined for final test conditions: PLATEPOL=0 and RATIODIS=0.

Parameter	Symbol	Test Conditions	Min	Typ	Max	Units
Thermal Offset Drift	$\Delta^T V_{oq}$		-0.4		+0.4	%Vdd
Thermal Sensitivity Drift	TC		-150		+150	ppm/ $^{\circ}\text{C}$
RMS Output noise	N_{rms}	$S = 1\%V_{dd}/\text{mT}$ (= 300 mV/mT @ $V_{dd}=5\text{V}$)			0.02	%Vdd
Voq Ratiometry	ΔV_{oq}	$V_{oq} = 50\% V_{dd}$ $\Delta V_{dd} = 10\% V_{dd}$	9.8		10.2	%
Sensitivity Ratiometry	ΔS	$\Delta V_{dd} = 10\% V_{dd}$ $B = \pm 45\text{ mT}$	9.8		10.2	%

Table 6: Accuracy specific parameters

9.3 Remarks to the achievable accuracy

The achievable target accuracy is dependent on the user's end of line calibration. The resolution for the offset and offset drift calibration is better than 0.1%Vdd. The trimming capability is higher than the measurement accuracy. An end user calibration can increase the accuracy of the system.

10 Thermometer Output

The thermometer output voltage is in the range from 367mV to 2930mV for temperatures ranging from -40°C to 125°C . The pin shall be able to sustain a low impedance connection to maximum 14V. The output is not ratiometric.

Parameter	Symbol	Test Conditions	Min	Typ	Max	Units
Offset	T_{35}	Output voltage with $T = 35\text{degC}$		1.38		V
Slope	T_{slope}			13.5		mV/degC
Accuracy	T_{acc}		-5		5	degC
Load capacitor	$C_{loadTherm}$	External through bonding wire		1	50	nF
Output current	$I_{outtherm}$		-0.1		+0.1	mA

Table 7: Thermometer output specifications



11 Programmable Items

11.1 Customer Parameter Table

Customers can re-program the parameters described in the table below by using the Melexis PTC-04 hardware and the Product Specific Functions (PSF) libraries provided by Melexis. We recommend using the latest version of the PSF and the latest version of the firmware with a communication speed of 10kbps (limited by a maximum output capacitor of 50nF). Software and firmware are available on Melexis Softdist Website platform. To arrange account and access to Softdist, contact your nearest Melexis Salesperson at www.melexis.com/contact.aspx.

Parameter	Bits	Factory Setting	Comment
OUTMODE	1	1	Capacitive load selection
DIAGINFAULT	1	0	Output impedance setting
ROUGHGAIN	3	Trimmed	Rough gain preamplifier
FINEGAIN	10	Trimmed	Fine gain amplifier from 0.4 to 1.0
XA	12	Trimmed	Offset compensation VOQ
PLATEPOL ⁽¹⁾	1	0	Change of sensitivity sign
CLAMPLOW	3	Trimmed	Clamping low level
CLAMPHIGH	3	Trimmed	Clamping high level
FILTCODE	3	0	Analog filter
OUTSLOPE	2	3	Power limitation of the output driver on high frequencies
RATIODIS ⁽¹⁾	1	0 ⁽²⁾ / 1 ⁽²⁾	Disable ratiometry between output signal and supply
TC1ST	7	Trimmed	Sensitivity temperature drift correction first order
TC2ND_COLD	5	Trimmed	Sensitivity temperature drift correction second order for cold
TC2ND_HOT	5	Trimmed	Sensitivity temperature drift correction second order for hot
OFFDRIFT_COLD	6	Trimmed	Offset temperature drift correction for cold temperatures
OFFDRIFT_HOT	6	Trimmed	Offset temperature drift correction for hot temperatures
MLXID	48	Programmed	MLX ID
CSTID	17	N/A	Customer ID

Table 8: Customer programmable parameters

(1) Changing these parameters has an impact on temperature calibration.

(2) 0 for CAA-005/CAA-007 and 1 for CAA-015



11.2 Description of Programmable Items

11.2.1 Output Mode Configuration (OUTMODE)

OUTMODE configures the output driver. For standalone applications (output of the sensor directly connected to a cable) we recommend using OUTMODE 1 because of better EMC robustness.

If the sensor is integrated on a PCB a smaller load capacitor can be applied. The output capacitor has to be considered in reference to OUTMODE.

OUTMODE	Output Driver
0	Integrated PCB mode, $C_L = 1..10nF$ ⁽¹⁾ ⁽²⁾
1	Standalone mode, $C_L = 5nF..50nF$ ⁽¹⁾ ⁽²⁾

Table 9: Output driver configuration max.

- (1) See section 14, $C_L = C_4$
 (2) Factory setting: OUTMODE=1

11.2.2 Output impedance mode (DIAGINFAULT)

DIAGINFAULT sets the output impedance mode.

DIAGINFAULT	Output impedance
0	Low impedance mode (normal mode)
1	High impedance mode (diagnostic level)

11.2.3 Sensitivity Programming (ROUGHGAIN and FINEGAIN)

The sensitivity is programmable with 3 bits for ROUGHGAIN and 10 bits for FINEGAIN from 5 to 45 mV/mT. Different option codes correspond to different sensitivity ranges:

Ordering Option Code	Typical Rough Gain	Typical Sensitivity [mV/mT]	Minimum Sensitivity [mV/mT]	Maximum Sensitivity [mV/mT]
CAA-005 / CAA-015	3	25	15	45
CAA-007	1	10	5	20

In order to have a safety margin regarding mechanical tolerances Melexis recommends designing the application in such a way that the typical sensitivity can be used with. If the target sensitivity of the module is out of the defined range (see table above), the hardware and software tools provided by Melexis will not be able to properly calibrate the sensor.

11.2.4 Offset Compensation VOQ (XA)

The offset is programmable with 12 bits in 1.25 mV steps over the full output range. This corresponds to a calibration resolution of 0.025 %VDD.

11.2.5 Sensitivity polarity (PLATEPOL)

The polarity of the sensitivity can be programmed by changing the value of the PLATEPOL bit

PLATEPOL	Polarity
0	Positive
1	Negative

Please note that the factory calibration is done with PLATEPOL=0 . Melexis cannot guarantee the magnetic specification if this parameter is changed during customer calibration.

11.2.6 Clamping Level Programming (CLAMPLOW, CLAMPHIGH)

The clamping levels limit the maximum and minimum output levels. The clamping levels are ratiometric (if RATIODIS = 0). The CLAMPLOW parameter adjusts the minimum output voltage level from 5%...10%Vdd. The CLAMPHIGH parameter sets the maximum output voltage level from 90...95%Vdd.

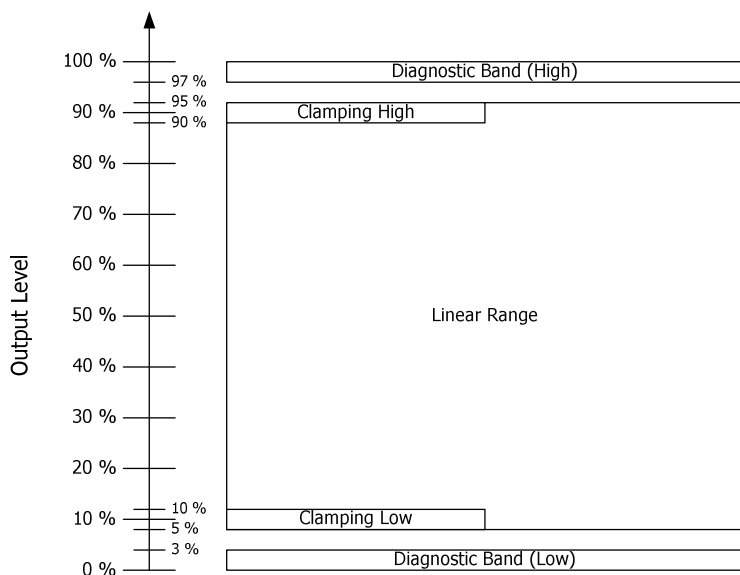

CLAMPLOW	Minimal output [%Vdd]
0	4.8
1	5.7
2	6.6
3	7.5
4	8.4
5	9.3
6	10.2
7	11.2

Table 11: Clamping low level table (typical values)



CLAMPHIGH	Maximal output [%Vdd]
0	90.6
1	91.4
2	92.4
3	93.3
4	94.3
5	95.2
6	96.1
7	97

Table 12: Clamp high level table (typical values)

The clamping functionality can be disabled by programming CLAMPLOW=CLAMPHIGH=7.

The clamping levels calibrated during final test are:

- 6%Vdd (+/- 0.5%Vdd) for CLAMPING LOW
- 94%Vdd (+/- 0.5%Vdd) for CLAMPING HIGH

11.2.7 Bandwidth and Filter Programming (FILTER)

FILTCODE allows adjusting the internal bandwidth of the sensor. The power on delays is subjected to the FILTCODE setting. For a low power consumption applications Melexis recommends FILTCODE=0 in a duty cycle mode.

FILTCODE	Typical Bandwidth [kHz]	Power on delays [ms]
0	60	0.25
1	9	0.35
2	40	0.28
3	2	0.73
4	9	0.5
5	0.9	1.45
6	4	0.82
7	0.2	5.2

Table 13: FILTCODE settings and typical bandwidth

11.2.8 Power Limitation (OUTSLOPE)

OUTSLOPE defines the power limit above which the output driver turns off to prevent damages to the IC. The power dissipated in the IC output driver is measured by the IC itself. The power is obtained by multiplying continuously the voltage across the conducting MOS driver by the output current I_{out} . When the power reaches the power limit, the output driver is switched off and on such that, on average, the measured power is maintained equal to the power limit. For OUTSLOPE = 3, the output driver is always enabled independently of the measured power.



MLX91207

High Speed Hall Sensor IC

Value	Power limitation [mW]
0	50
1	100
2	200
3	DISABLED

Table 14: Output power limitation

11.2.9 Output Ratiometry (RATIODIS)

RATIODIS allows enabling and disabling the ratiometry of the output in reference to the supply voltage by setting respectively 0 and 1 in the EEPROM.

Please note that Melexis cannot guarantee the magnetic specifications after changing the ratiometry factory setting. Different product versions with different ratiometry settings are available:

MLX91207 version	Ratiometry Default value
CAA-005	0 (Enabled)
CAA-007	
CAA-015	1 (Disabled)

11.2.10 Sensitivity Temperature Drift Programming (TC1ST, TC2ND_COLD, TC2ND_HOT)

First order sensitivity temperature drift can be trimmed from -2000 to 2000 ppm/K with TC1ST. The programming resolution is 40 ppm/K. Second order sensitivity temperature drift can be trimmed from -6 to 6 ppm/K² with TC2ND. The programming resolution is 0.4/ppm/K². The second order can also be seen as third order correction since cold and hot sides are independently adjusted. The Linear Temperature Coefficient of the sensitivity will be trimmed to a target value of 0 ppm/°C with a tolerance of +/- 150 ppm/°C by the 7 bits programming of the TC1ST.

11.2.11 Offset Temperature Drift Programming (OFFDRIFT_COLD, OFFDRIFT_HOT)

Offset temperature drift can be trimmed from -2.25 to +2.25 mV/K. The programming resolution is 0.075 mV/K. This first order correction is done independently for temperatures over 25C and below 25C. The offset drift corrections are ratiometric (if RATIODIS = 0). The parameter will be trimmed to 0 mV/°C by Melexis. The end user can adjust this parameter after the assembly into their product in order to achieve highest accuracy.



MLX91207

High Speed Hall Sensor IC

11.2.12 Product Identification (MLXID, CSTID)

MLXID

A 48-bit MLX ID is used to guarantee MLX traceability (lot number, wafer number, wafer position & PSF option code) and is split up into a 3x16 bit register (MLXID1, MLXID2, MLXID3).

The programmed PSF option code is stored in MLXID3[2..0] and defines the gain setting used during the factory calibration .

PSF Option Code ⁽¹⁾ MLXID3[2..0]	Ordering Option Code ⁽²⁾
3	XXX-005
3	XXX-015
1	XXX-007

- (1) The option code mentioned in all 91207 related documentation (application notes, PSF and User Interface) refers to the PSF Option Code.
- (2) The Ordering Option Code mentioned on the page 1 of this datasheet refers to the Ordering Code, which defines the Chip version and the sensitivity range of the sensor

CSTID

A 17-bit customer ID is available to create a dedicated traceability system



12 Self Diagnostic

The MLX91207 provides numerous self diagnostic features. Those features increase the robustness of the IC functionality as it will prevent the IC from providing an erroneous output signal in case of internal or external failure modes ("fail-safe").

Error	Action	Effect on Outputs	Remarks
Calibration Data CRC Error (at power up and in normal working mode)	Fault mode	High Impedance mode ⁽¹⁾	Pull down resistive load => Diag Low Pull up resistive load => Diag High
Power On delay		High Impedance mode ⁽¹⁾	1 ms max in high impedance followed by settling
Undervoltage Mode ⁽²⁾	IC reset ⁽³⁾	High Impedance mode ⁽¹⁾	300mV Hysteresis
Overvoltage detection Mode 1 ⁽⁴⁾ (Threshold : min 7.9 V – max 9.5 V)	IC is switched off (internal supply)	High Impedance mode ⁽¹⁾	I _{dd} < 1mA 500mV to 1500mV Hysteresis
Overvoltage detection Mode 2 ⁽⁵⁾ (Threshold : min 6.8V – max 7.5V)	IC reset ⁽³⁾	High Impedance mode ⁽¹⁾	100mV Hysteresis
Broken Vss	IC is switched off	High Impedance ⁽⁶⁾	With some restrictions on pull-up/pull-down resistors on OUT and TEMPOUT, see Chapter 8, page 5, Table 3
Broken Vdd	IC is switched off	High Impedance ⁽⁷⁾	With some restrictions on pull-up/pull-down resistors on OUT, see Chapter 8, page 5, Table 3

Table 15: Self diagnostic

- (1) Refer to Table 3: General electrical parameter, parameter High-impedance modes levels
- (2) Refer to Table 3: General electrical parameter, parameter Under-voltage detection
- (3) The internal supply is regulated but the digital sequencer (Hall element spinning) is stopped
- (4) Refer to Table 3: General electrical parameter, parameter Over-voltage detection mode 1
- (5) Refer to Table 3: General electrical parameter, parameter Over-voltage detection mode 2
- (6) Refer to Table 3: General electrical parameter, parameter BrokenVss Output Level
- (7) Refer to Table 3: General electrical parameter, parameter BrokenVdd Output Level

13 Applications Information

13.1 Current Measurement

As a typical application the MLX91207 can be used as a non intrusive current sensor. A current flowing through a conductor generates a magnetic field around it, which is directly proportional to the amount of current flow. The field generated is rather small and hard to measure accurately compared to the current, therefore other approaches are needed in order to reach good solutions.

An easy and well established principle is the use of a ring shaped concentrator (or core) made of soft ferromagnetic material with a small gap. The current conductor is passed through the ring and generates a magnetic field, which is concentrated and directed through the gap. The sensor is placed in the gap of the core and is able to measure the increased magnetic flux density more reliably.

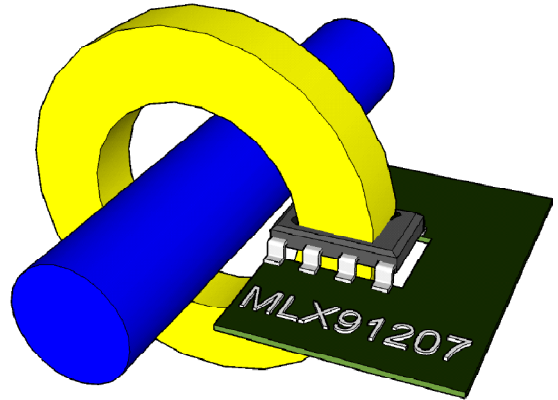

Figure 4: Current Measurement Application

13.2 Linear Position

An additional application suitable for the MLX91207 is the detection of a relative linear position of a magnet-sensor system. A permanent magnet generates a magnetic field in its surrounding dependent on the magnetization type, the magnet material and geometry. The MLX91207 should be placed close to the magnet and the movement axis should be chosen in a way to get a linear function between flux density and movement. A possible solution would be a cylindrically shaped, axially magnetized magnet with the movement axis parallel to the sensor surface. The magnet provides a magnetic field, which is linear for a certain movement range, positive in one direction and negative in the other direction. The output signal of the sensor is directly proportional to the magnet position.

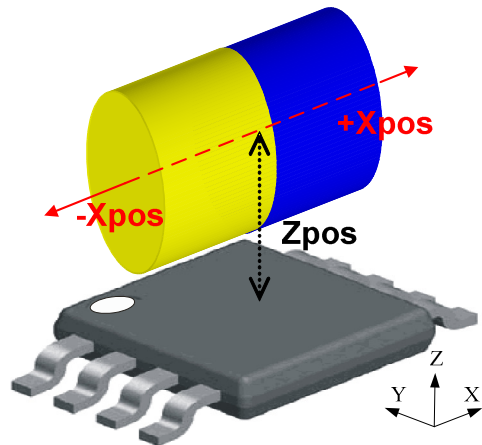

Figure 5: Linear Position Application

14 Recommended Application Diagrams

14.1 Resistor and Capacitor Values

Part	Description	Value	Unit
C1	Supply capacitor, EMI, ESD	10 - 220	nF
C2	Regulator buffer capacitor, decoupling, EMI, ESD	10 - 220	nF
C3	Decoupling, EMI, ESD	5 - 50	nF
C4	Decoupling, EMI, ESD	5 - 50 ⁽¹⁾	nF
R1	Pull up or pull down resistor	10 - 30	k Ω

Table16: Resistor and capacitor value

(1) When OUTMODE=0 (not recommended in the application), capacitor C4 should be 1nF or less.

14.2 Pull down resistor for diagnostic low

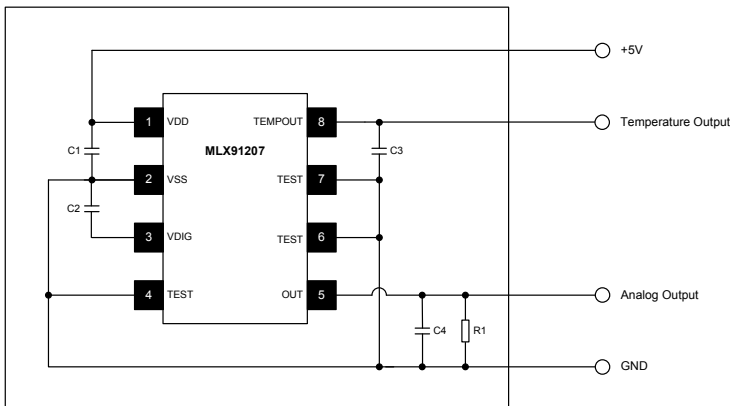

Figure 6: Diagnostic low

14.3 Pull up resistor for diagnostic high

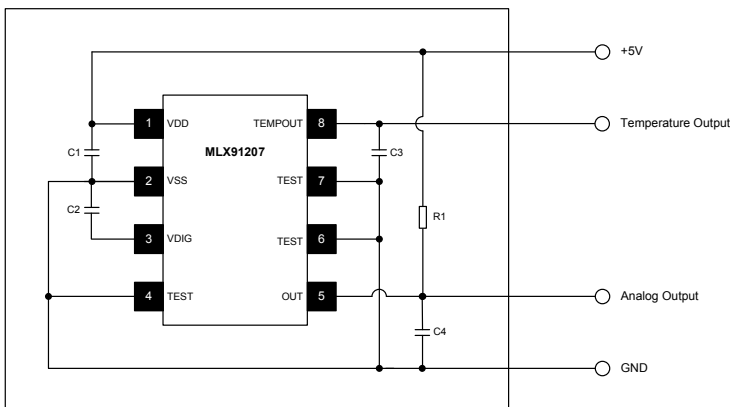

Figure 7: Diagnostic high

15 Standard information regarding manufacturability of Melexis products with different soldering processes

Our products are classified and qualified regarding soldering technology, solderability and moisture sensitivity level according to following test methods:

Reflow Soldering SMD's (Surface Mount Devices)

- IPC/JEDEC J-STD-020
Moisture/Reflow Sensitivity Classification for Nonhermetic Solid State Surface Mount Devices (classification reflow profiles according to table 5-2)
- EIA/JEDEC JESD22-A113
Preconditioning of Nonhermetic Surface Mount Devices Prior to Reliability Testing (reflow profiles according to table 2)

Wave Soldering SMD's (Surface Mount Devices) and THD's (Through Hole Devices)

- EN60749-20
Resistance of plastic- encapsulated SMD's to combined effect of moisture and soldering heat
- EIA/JEDEC JESD22-B106 and EN60749-15
Resistance to soldering temperature for through-hole mounted devices

Iron Soldering THD's (Through Hole Devices)

- EN60749-15
Resistance to soldering temperature for through-hole mounted devices

Solderability SMD's (Surface Mount Devices) and THD's (Through Hole Devices)

- EIA/JEDEC JESD22-B102 and EN60749-21
Solderability

For all soldering technologies deviating from above mentioned standard conditions (regarding peak temperature, temperature gradient, temperature profile etc) additional classification and qualification tests have to be agreed upon with Melexis.

The application of Wave Soldering for SMD's is allowed only after consulting Melexis regarding assurance of adhesive strength between device and board.

Melexis is contributing to global environmental conservation by promoting **lead free** solutions. For more information on qualifications of **RoHS** compliant products (RoHS = European directive on the Restriction Of the use of certain Hazardous Substances) please visit the quality page on our website:

<http://www.melexis.com/quality.aspx>

16 ESD Precautions

Electronic semiconductor products are sensitive to Electro Static Discharge (ESD). Always observe Electro Static Discharge control procedures whenever handling semiconductor products.

17 Package Information

17.1 SOIC8 Package Dimensions

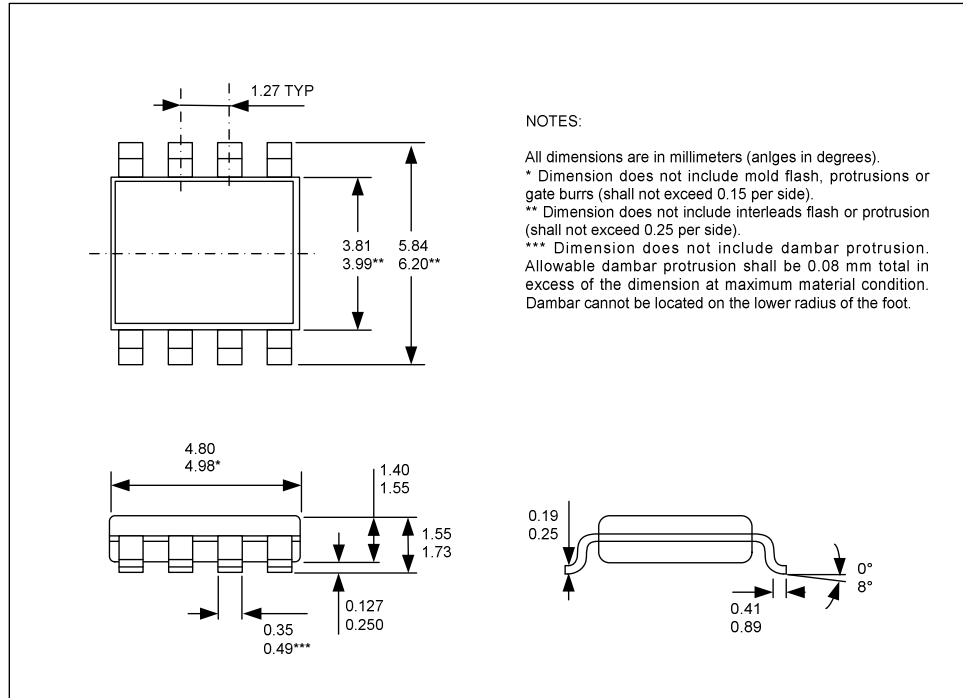
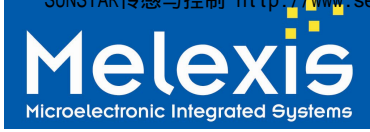

Figure 8: Package dimensions



MLX91207

High Speed Hall Sensor IC

17.2 SOIC8 Pin Out and Marking

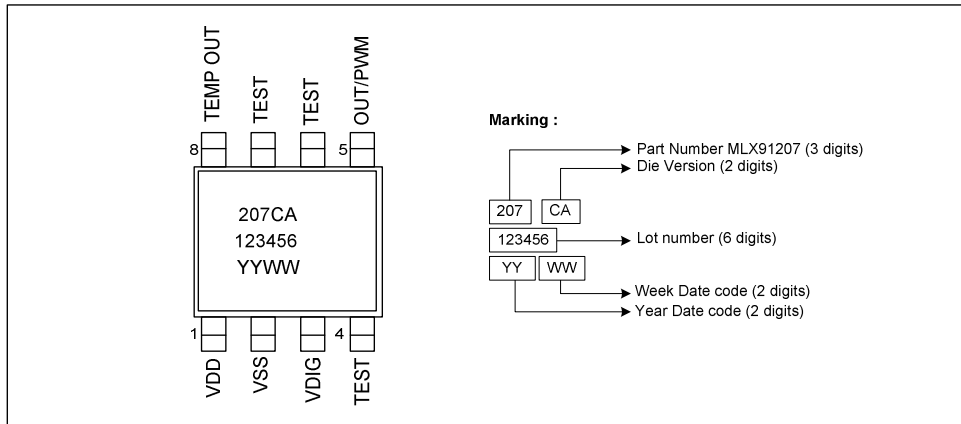

Figure 9: Pin out and marking

Note: the option code is not marked on the package. It can be found by reading back the EEPROM (See chapter 11.2.12) and on the tape-on-reel label information

SOIC8 Hall Plate Positioning (preliminary)

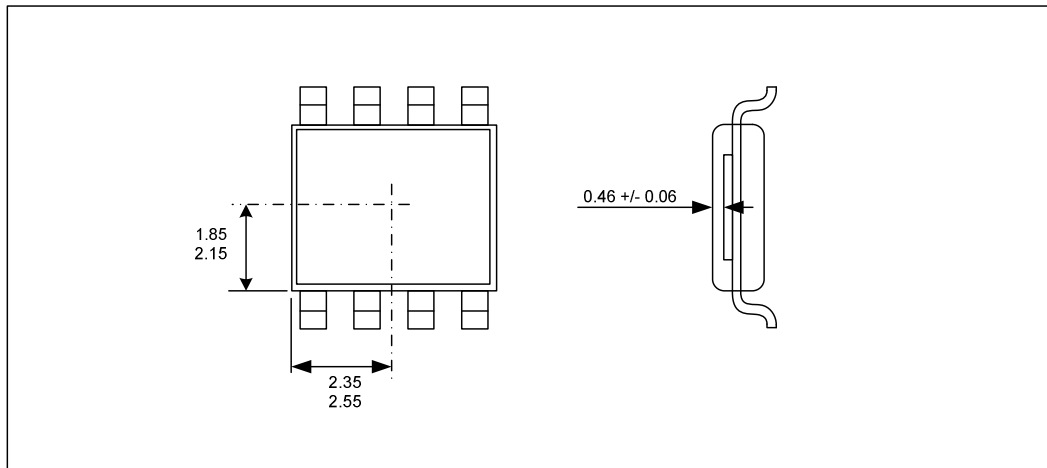

Figure 10: Hall Plate positioning (preliminary)



MLX91207

High Speed Hall Sensor IC

18 Related documents and tools

18.1 Related documents

- User Interface UI MLX91207 Description
- Product Specific Functions PSF MLX91207 Description
- PTC-04 Daughter Board DB-HALL-03 Data Sheet

The latest version of these documents is available on the Melexis Softdist platform. To arrange account and access to Softdist, contact your nearest Melexis Salesperson at www.melexis.com/contact.aspx.

- Non intrusive current sensing with MLX91207 application note
- MLX91207 for PDU solutions application note
- Calibrating the MLX91206/MLX91207 application note
- Shielding for Triaxis current sensors application note

The latest version of these documents is available on the MLX91207 page on the Melexis website: <http://www.melexis.com/Hall-Effect-Sensor-ICs/Special-Purpose-Hall-ICs/MLX91207-757.aspx>

18.2 Related software

- MLX91207 Firmware
- MLX91207 Product Specific Functions (PSF)
- MLX91207 User Interface
- MLX PTC-04 Product Specific Functions
- MLX PTC-04 User Interface

The latest version of these pieces of software is available on the Melexis Softdist platform. To arrange account and access to Softdist, contact your nearest Melexis Salesperson at www.melexis.com/contact.aspx.

18.3 Related hardware

- PTC-04 Programmer for Melexis PTC devices
- PTC-04 Daughter Board DB-HALL-03 for MLX91207



MLX91207

High Speed Hall Sensor IC

19 Disclaimer

Devices sold by Melexis are covered by the warranty and patent indemnification provisions appearing in its Term of Sale. Melexis makes no warranty, express, statutory, implied, or by description regarding the information set forth herein or regarding the freedom of the described devices from patent infringement. Melexis reserves the right to change specifications and prices at any time and without notice. Therefore, prior to designing this product into a system, it is necessary to check with Melexis for current information. This product is intended for use in normal commercial applications. Applications requiring extended temperature range, unusual environmental requirements, or high reliability applications, such as military, medical life-support or life-sustaining equipment are specifically not recommended without additional processing by Melexis for each application.

The information furnished by Melexis is believed to be correct and accurate. However, Melexis shall not be liable to recipient or any third party for any damages, including but not limited to personal injury, property damage, loss of profits, loss of use, interrupt of business or indirect, special incidental or consequential damages, of any kind, in connection with or arising out of the furnishing, performance or use of the technical data herein. No obligation or liability to recipient or any third party shall arise or flow out of Melexis' rendering of technical or other services.

© 2012 Melexis NV. All rights reserved.

For the latest version of this document, go to our website at
www.melexis.com

Or for additional information contact Melexis Direct:

Europe, Africa, Asia:	America:
Phone: +32 1367 0495	Phone: +1 248 306 5400
E-mail: sales_europe@melexis.com	E-mail: sales_usa@melexis.com

ISO/TS 16949 and ISO14001 Certified