

**tyco**  
Electronics

**AXICOM**

## The Best Relaytion



## FT2 / FU2 Relay



# FT2 / FU2 Relay

**AXICOM**

2 pole telecom/signal relay  
Through Hole Type (THT)  
Non – polarized. non-latching 1 coil

### Features

- Telecom/signal relay (dry circuit, test access, ringing)
- Slim line 15 x 7.5 mm, 0.59 x 0.295 inch
- Switching current 1.25 A
- 2 changeover contacts (2 form C / DPDT)
- Bifurcated contacts
- High sensitive 24 V and 48 V coil versions
- Meets Bellcore GR 1089, FCC Part 68 and ITU-T K20  $\geq 2500$  V between coil and contacts

### Typical applications:

- Communications equipment  
Linecard application – analog, ISDN, xDSL  
PABX  
Voice over IP
- Office and business equipment
- Measurement and control equipment
- Consumer electronics  
Set top boxes, HiFi
- Medical equipment

### Options:

High Dielectric Version (HDV) with  $> 5000$  V surge voltage between coil and contacts



CSA-C22.2 No.14-95  
CSA-C22.2 No.950-95

File No. 176679-1079886



UL 508  
UL1950 3<sup>rd</sup> ed.

File No. E111441



CECC16504-001



QC160504-CH0001

IEC/EN60950

IEC Ref. Cert. No. 10xx

### Insulation category:

Supplementary insulation according IEC / EN 60950 and UL 1950

Working voltage  $\geq 300$  Vrms

Mains supply voltage  $\geq 250$  Vrms

Repetitive peak voltage: 1500 V

Pollution degree: Internal: 1  
External: 2

Flammability classification: V-0

Maximum operating temperature: 85 °C

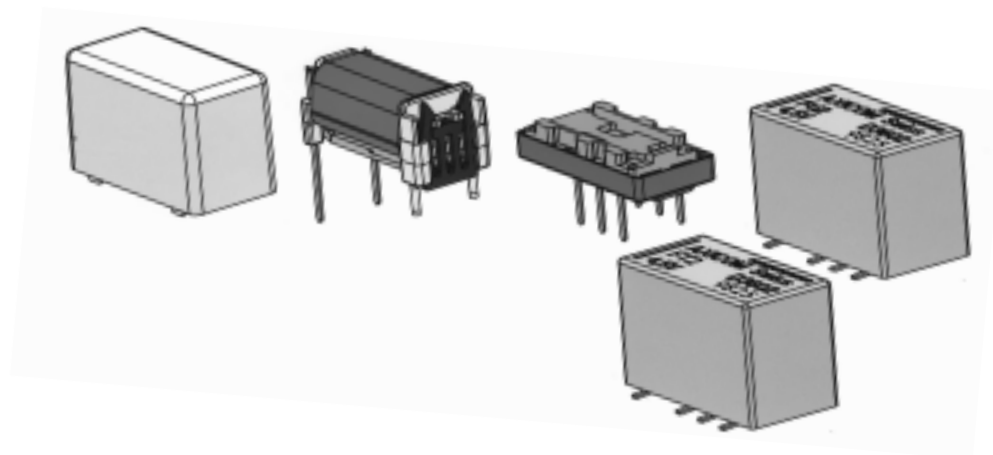

# FT2 / FU2 Relay



## Dimensions

	FT2 THT		FU2 SMT long terminals		FU2 SMT short terminals	
	mm	inch	mm	inch	mm	inch
L	15 ± 0.05	0.590 ± 0.002	15 ± 0.15	0.590 ± 0.002	15 ± 0.05	0.590 ± 0.002
W	7.5 ± 0.05	0.295 ± 0.002	7.5 ± 0.05	0.295 ± 0.002	7.6 ± 0.05	0.296 ± 0.002
H	9.6 ± 0.03	0.377 ± 0.001	10 ± 0.15	0.393 ± 0.006	10 ± 0.15	0.393 ± 0.006
T	3.3 ± 0.3	0.129 ± 0.011	N/A	N/A	N/A	N/A
T1	N/A	N/A	9.2 ± 0.2	0.362 ± 0.008	7.5 ± 0.2	0.295 ± 0.008
T2	5.08	0.200	5.08	0.200	5.08	0.200
Tw	0.5	0.020	0.5	0.020	0.5	0.020
S	0.35 ± 0.03	0.013 ± 0.001	N/A	N/A	N/A	N/A

### FT2: THT Version

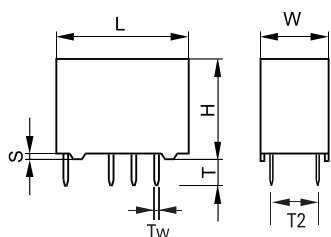

### FU2: SMT Version

Long terminals (W)

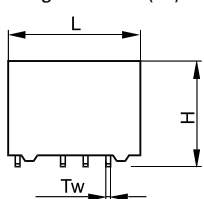

Short terminals (N)

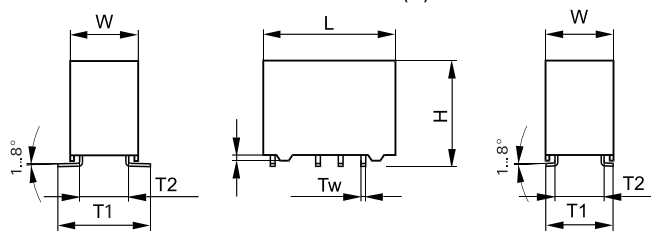

### Mounting hole layout

View onto the component side of the PCB

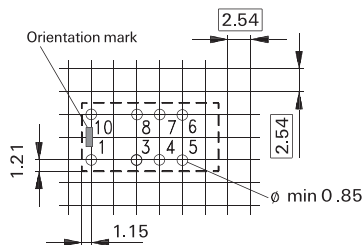

Basic grid 2.54 mm

### Solder pad layout

View onto the component side of the PCB

Long terminals

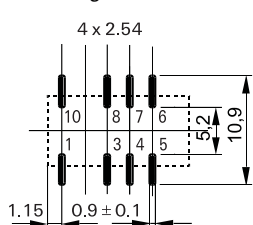

Short terminals

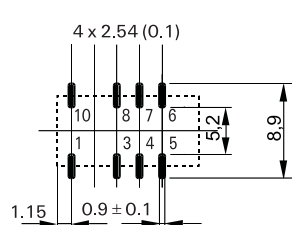

### Terminal assignment

Relay - top view

non-latching 1 coil  
release condition

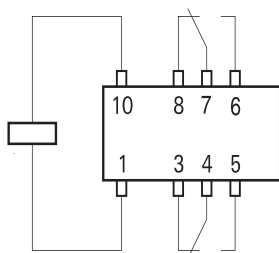

# FT2 / FU2 Relay



## Coil Data (values at 23°C)

Nominal voltage $U_{nom}$	Operate voltage range		Release voltage Minimum	Nominal power consumption	Resistance	Coil number
	Minimum voltage $U_I$	Maximum voltage $U_{II}$				
Vdc	Vdc	Vdc	Vdc	mW	$\Omega / \pm 10\%$	

### Sensitive version non-latching 1 coil

FT2 D34\*\* THT  
FU2 D35\*\* W SMT long term.  
FU2 D35\*\* N SMT short term.

3	2.25	4.2	0.30	200	45	21
4	3.00	5.7	0.40	200	114	29
4.5	3.38	6.4	0.45	200	101	22
5	3.75	7.1	0.50	200	125	23
6	4.5	8.5	0.60	200	180	24
9	6.75	12.7	0.90	200	405	25
12	9.00	17.0	1.20	200	720	26
24	18.00	33.9	2.40	240	2400	27
48	36.00	67.9	4.8	240	9600	28

### Standard version non-latching

FT2 D34\*\* THT  
FU2 D35\*\* W SMT long term.  
FU2 D35\*\* N SMT short term.

3	2.25	5.2	0.3	300	30	01
4.5	3.38	7.8	0.45	300	68	02
5	3.75	8.7	0.50	300	83	03
6	4.5	10.4	0.60	300	120	04
9	6.75	15.6	0.90	300	270	05
12	9.00	20.8	1.20	300	480	06
24	18.00	40.8	2.40	300	1920	07
48	36.00	81.6	4.80	300	768	08

### High dielectric version non-latching

FT2 D34\*\* THT HDV

3	2.25	4.2	0.30	200	45	91
5	3.75	7.1	0.50	200	125	93
12	9.00	17.0	1.20	200	720	96
24	18.00	33.9	2.40	240	2400	97

Further coil versions are available on request.

$U_I$  = Minimum voltage at 23° C after pre-energizing with nominal voltage without contact current

$U_{II}$  = Maximum continuous voltage at 23°

The operating voltage limits  $U_I$  and  $U_{II}$  depend on the temperature according to the formula:

$$U_{I \text{ t amb}} = K_I \cdot U_{I \text{ 23}^\circ \text{ C}}$$

and

$$U_{II \text{ t amb}} = K_{II} \cdot U_{II \text{ 23}^\circ \text{ C}}$$

$t_{amb}$  = Ambient temperature

$U_{I \text{ t amb}}$  = Minimum voltage at ambient temperature,  $t_{amb}$

$U_{II \text{ t amb}}$  = Maximum voltage at ambient temperature,  $t_{amb}$

$k_I, k_{II}$  = Factors (dependent on temperature), see diagram

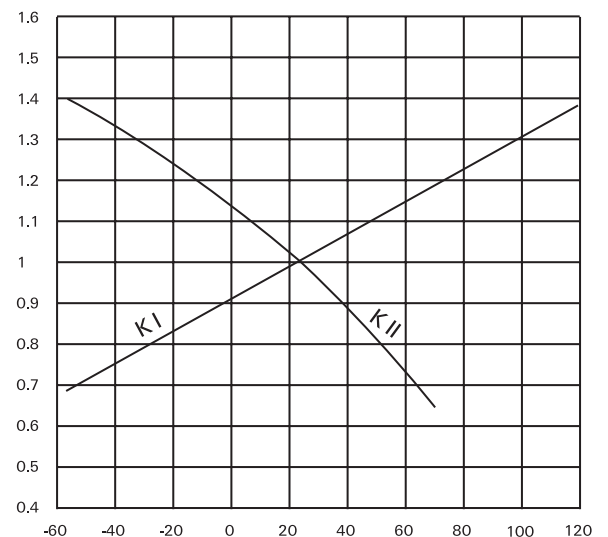

Ambient temperature  $t_{amb}$  [°C] →

## FT2 / FU2 Relay

**AXICOM**

Contact Data	Standard Version	High Dielectric Version
Number of contacts and type	2 changeover contacts	
Contact assembly	Bifurcated contacts	
Contact material	Silver nickel, gold-covered	Palladium-ruthenium, gold covered
Limiting continuous current at max. ambient temperature	1.25 A	2 A
Maximum switching current	2 A	2 A
Maximum switching voltage	125 Vdc 250 Vac	220 Vdc 250 Vdc
Maximum switching capacity	30 W, 62.5 VA	60 W, 62.5 VA
Thermoelectric potential	< 10 $\mu$ V	
Initial contact resistance / measuring condition: 10 mA / 20 mV	< 70 m $\Omega$	
Electrical endurance at contact application 0 ( $\geq 12$ V / $\geq 10$ mA) at cable load open end	min. 2.5 x 10 <sup>6</sup> operations min. 2.0 x 10 <sup>6</sup> operations	
Resistive load 125 Vdc / 0.24 A - 30 W 250 Vdc / 0.25 A - 62.5 VA 24 Vdc / 1.25 A - 30 W	min. 1 x 10 <sup>5</sup> operations min. 1 x 10 <sup>5</sup> operations min. 1 x 10 <sup>5</sup> operations	
Mechanical endurance	typ. 10 <sup>8</sup> operations	
UL/CSA ratings	125 Vdc / 1.25 A 125 Vac / 1.25 A	

Insulation	Standard Version	High Dielectric Version
Insulation resistance at 500 VDC	> 10 <sup>9</sup> $\Omega$	> 10 <sup>9</sup> $\Omega$
Dielectric test voltage (1 min)		
between coil and contacts	1500 Vrms	3500 Vrms
between adjacent contact sets	1500 Vrms	1800 Vrms
between open contacts	1500 Vrms	1800 Vrms
Surge voltage resistance		
according to Bellcore TR-NWT-001089 (2 / 10 $\mu$ s)		
between coil and contacts	2500 V	5000 V
between adjacent contact sets	1500 V	2500 V
between open contacts	1500 V	2500 V
according to FCC 68 (10 / 160 $\mu$ s)		
between coil and contacts	2500 V	5000 V
between adjacent contact sets	1500 V	2500 V
between open contacts	1500 V	2500 V

High Frequency Data	
Capacitance	
between coil and contacts	max. 4 pF
between adjacent contact sets	max. 1 pF
between open contacts	max. 1 pF
RF Characteristics	
Isolation at 100 MHz / 900 MHz	- 30.6 dB / - 13.7 dB
Insertion loss at 100 MHz / 900 MHz	- 0.02 dB / - 0.50 dB
V.S.W.R. at 100 MHz / 900 MHz	1.02 / 1.27

# FT2 / FU2 Relay



## General data

Operate time at $U_{nom}$ typ. / max.	3 ms / 5 ms
Release time without diode in parallel, typ. / max.	2 ms / 5 ms
Release time with diode in parallel, typ. / max.	4 ms / 5 ms
Bounce time at closing contact, typ. / max.	1 ms / 5 ms
Maximum switching rate without load	50 operations/s
Ambient temperature	-55° C ... +85° C
Thermal resistance	< 165 K/W
Maximum permissible coil temperature	125° C
Vibration resistance (function)	10 g
Shock resistance, half sinus, 11 ms	10 to 1000 Hz
	15 g (function)
Degree of protection	500 g (damage)
	immersion cleanable, IP 67
Needle flame test	application time 20 s, no burning or glowing
Mounting position	any
Processing information	Ultrasonic cleaning is not recommended
Weight (mass)	max. 3 g
Resistance to soldering heat	260° C / 10 s

All data refers to 23° C unless otherwise specified.

## Recommended soldering conditions

Soldering conditions according CECC 00802

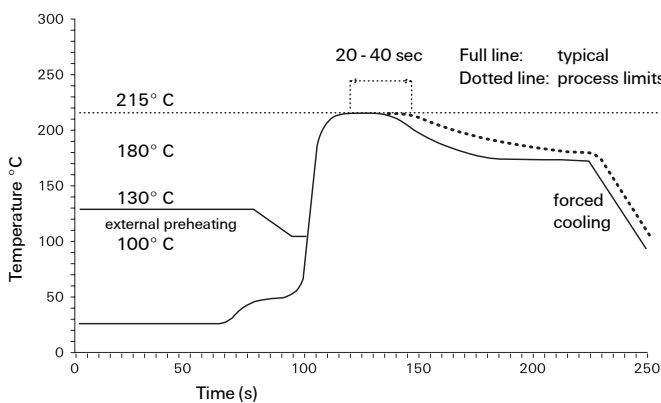

Vapor Phase Soldering: Temperature/Time Profile (Lead Temperature)

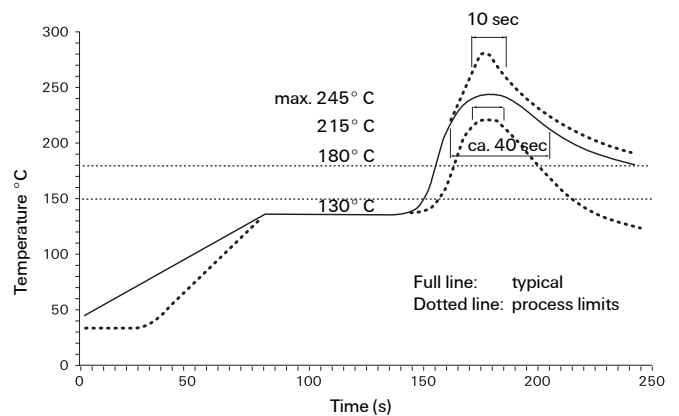

Infrared Soldering: Temperature/Time Profile (Lead Temperature)

# FT2 / FU 2 Relay



## Packing

Dimensions in mm

Tube for THT version - 50 relays per stick, 1000 relays per box

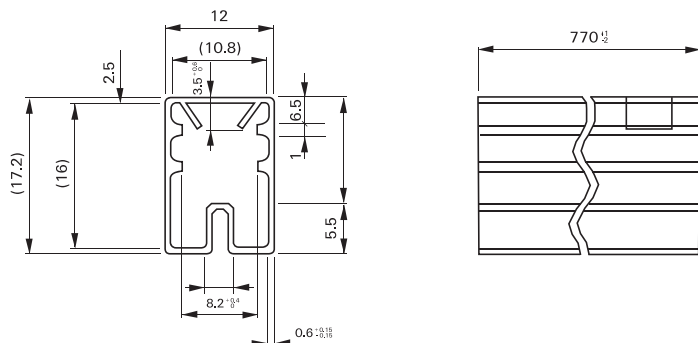

Tape and reel for SMT version with long terminals - 400 relays per reel, 2000 relays per box

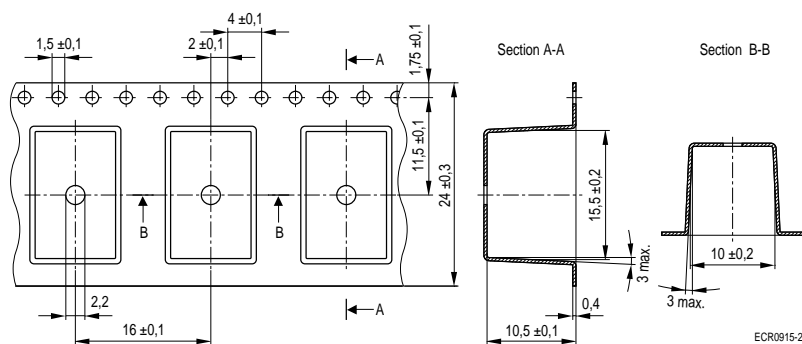

Tape and reel for SMT version with short terminals - 500 relays per reel, 2500 relays per box

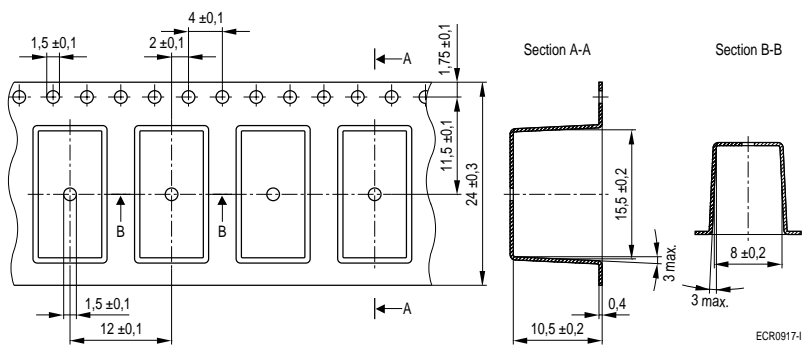

## Reel dimension

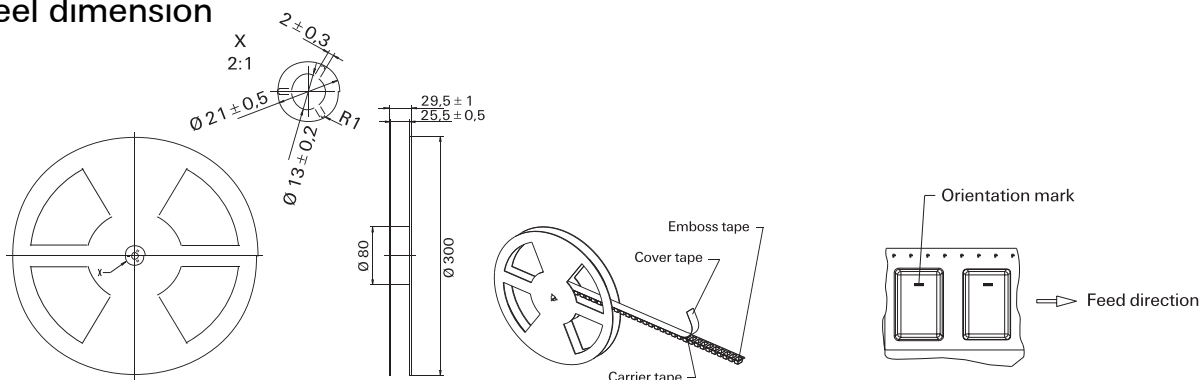

## FT2 / FU 2 Relay

**AXICOM**

## Ordering Information

Relay Code	Tyco Part Number	Relay Code	Tyco Part Number
D3401	0-1462035-1	D3506N	1-1462036-1
D3402	0-1462035-2	D3506W	1-1462036-2
D3403	0-1462035-3	D3507N	1-1462036-3
D3404	0-1462035-4	D3507W	1-1462036-4
D3405	0-1462035-5	D3508N	1-1462036-5
D3406	0-1462035-6	D3508W	1-1462036-6
D3407	0-1462035-7	D3521N	1-1462036-7
D3408	0-1462035-8	D3521W	1-1462036-8
D3421	0-1462035-9	D3522N	1-1462036-9
		D3522W	2-1462036-0
D3422	1-1462035-0	D3523N	2-1462036-1
D3423	1-1462035-1	D3523W	2-1462036-2
D3424	1-1462035-2	D3524N	2-1462036-3
D3425	1-1462035-3	D3524W	2-1462036-4
D3426	1-1462035-4	D3525N	2-1462036-5
D3427	1-1462035-7	D3525W	2-1462036-6
D3428	1-1462035-8	D3526N	2-1462036-7
D3429	1-1462035-9	D3526W	2-1462036-8
D3501N	0-1462036-1	D3527N	2-1462036-9
D3501W	0-1462036-2	D3527W	9-1462036-1
D3502N	0-1462036-3	D3528N	9-1462036-3
D3502W	0-1462036-4	D3528W	9-1462036-5
D3503N	0-1462036-5	D3529N	3-1462036-0
D3503W	0-1462036-6	D3529W	3-1462036-1
D3504N	0-1462036-7	D3491	2-1462035-0
D3504W	0-1462036-8	D3493	1-1462035-5
D3505N	0-1462036-9	D3496	2-1462035-4
D3505W	1-1462036-0	D3497	2-1462035-5

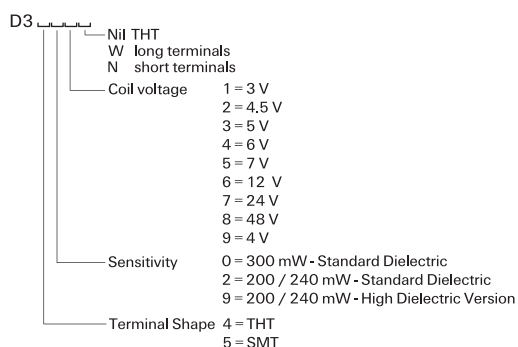



## IM Relays

4<sup>th</sup> generation slim line – low profile polarized 2 c/o telecom relay with bifurcated contacts, available as non latching or latching relay with 1 coil. Nominal voltage range from 1.5... 24 V, coil power consumption of 140... 200 mW, latching relays with 1 coil 100 mW. The IM relay is available as through hole and surface mount type (J-Legs and Gull Wings) and capable to switch loads up to 60 W/62,5 VA. Dielectric strength fulfills the Bellcore requirements according GR 1089 (2,5 kV – 2 / 10  $\mu$ s) and FCC part 68 (1,5 kV – 10 / 160  $\mu$ s). The IM is CECC/IECQ approved and certified in accordance with IEC/EN 60950 and UL1950. Dimensions approx. 10 x 6 mm board space and 5.65 mm height.

## P2 Relays

3<sup>rd</sup> generation polarized 2 c/o telecom relay with bifurcated contacts, available as non latching or latching relay with 1 or 2 coils. Nominal voltage range from 3 ... 24 V, coil power consumption 140 mW, latching relays with 1 coil 70 mW. The P2 relay is available as through hole or surface mount type and capable to switch currents up to 5 A. Dielectric strength fulfills the Bellcore requirements according GR 1089 (2,5 kV – 2 / 10  $\mu$ s) and FCC part 68 (1,5 kV – 10 / 160  $\mu$ s). Dimensions approx. 15 x 7,5 mm board space and 10 mm height.

## FX Relays

3<sup>rd</sup> generation polarized 2 c/o telecom relay with bifurcated contacts, available as non latching or latching relay with 1 coil. Nominal voltage range from 3 ... 48 V, coil power consumption of 80 ... 260 mW for the high sensitive version, 140... 300 mW for the standard version, latching relays with 1 coil 100 mW. The FX2 relay is available as through hole type and capable to switch loads up to 60 W/62,5 VA. Dielectric strength fulfills the Bellcore requirements according GR 1089 (2,5 kV – 2 / 10  $\mu$ s) and FCC part 68 (1,5 kV – 10 / 160  $\mu$ s). The FX2 is CECC/IECQ approved and certified in accordance with IEC/EN 60950 and UL1950. Dimensions approx. 15 x 7,5 mm board space and 10,7 mm height.

## FT2 / FU2 Relays

3<sup>rd</sup> generation non polarized, non latching 2 c/o telecom relay with bifurcated contacts. Nominal voltage range from 3 ... 48 V, coil power consumption 200 ... 300 mW. Most sensitive 48 V relay. Available as through hole and surface mount type. Dielectric strength fulfills the Bellcore requirements according GR 1089 (2,5 kV – 2 / 10  $\mu$ s) and FCC part 68 (1,5 kV – 10 / 160  $\mu$ s). The FT2/FU2 is CECC/IECQ approved and certified in accordance with IEC/EN 60950 and UL1950. Dimensions approx. 15 x 7,5 mm board space and 10 mm height.

## FP2 Relays

3<sup>rd</sup> generation polarized 2 c/o telecom relay with bifurcated contacts, available as non latching or latching relay with 1 or 2 coils. Nominal voltage range from 3 ... 48 V, coil power consumption of 80 ... 260 mW for the high sensitive version, 140... 300 mW for the standard version, latching relays with 1 coil 100 mW. The FP2 relay is available as through hole type and capable to switch loads up to 30 W/62,5 VA. Dielectric strength fulfills FCC part 68 (1,5 kV – 10 / 160  $\mu$ s). The FP2 is CECC/IECQ approved. Dimensions approx. 14 x 9 mm board space and 5 mm height.

## MT2 / MT4

2<sup>nd</sup> generation non polarized, non latching 2 c/o and 4 c/o telecom and signal relay with bifurcated contacts. Nominal voltage range from 4.5 ... 48 V, coil power consumption 150/200/300/400 and 550 mW, and 300 mW (MT4). Dielectric strength fulfills the

requirements according FCC part 68 (1,5 kV – 10 / 160  $\mu$ s) for both and the Bellcore requirements according GR 1089 (2,5 kV – 2 / 10  $\mu$ s) the MT4 only.

Dimensions MT2 approx. 20 x 10 mm board space and 11 mm height, MT4 approx. 20 x 15 mm board space and 11 mm height.

## D2n Relays

2<sup>nd</sup> generation non polarized 2 c/o relay for telecom and various other applications. Nominal voltage range from 3 ... 48 V, coil power consumption from 150 ... 500 mW. The D2n relay is capable to switch currents up to 3 A. Dielectric strength fulfills the requirements according FCC part 68 (1,5 kV – 10 / 160  $\mu$ s). Dimensions approx. 20 x 10 mm board space and 11,5 mm height.

## P1 Relays

Extremely sensitive, polarized 1 c/o relay with bifurcated contacts for a wide range of applications, available as non latching or latching relay with 1 or 2 coils. Nominal voltage range from 3 ... 24 V, coil power consumption 65 mW, latching relays with 1 coil 30 mW. The P1 relay is available as through hole or surface mount type and capable to switch currents up to 1 A. Dielectric strength fulfills the requirements according FCC part 68 (1,5 kV – 10 / 160  $\mu$ s). Dimensions approx. 13 x 7,6 mm board space and 7 mm height for THT or 8 mm height for SMT version.

## W11 Relays

Low cost, non polarized 1 c/o relay for various applications. Nominal voltage range from 3 ... 24 V, coil power consumption 450 mW, sensitive versions 200 mW. The W11 relay is capable to switch currents up to 3 A. Dielectric strength 1000 Vrms. Dimensions approx. 15,6 x 10,6 mm board space and 11,5 mm height.

## Reed Relays

High sensitive, non polarized relay for telecom and various other applications, available with 1 n/o, 2 n/o or 1c/o contacts. Nominal voltage range from 5 ... 24 V, coil power consumption 50...280 mW for 1 n/o and 125 ... 280 mW for 2 n/o or 1 c/o versions. Reedrelays are available in DIP or SIL housing and capable to switch currents up to 0,5 A. Integrated diode and/or electrostatic shield optional. Dielectric strength 1500 Vdc. Dimensions approx. 19,3 x 7 mm board space and 5 ... 7,5 mm height for DIP or 19,8 x 5 mm board space and 7,8 mm height for SIL version.

## Cradle Relays

Extremely reliable and mature relay family of 1<sup>st</sup> generation for various signal switching applications. Available as non polarized, polarized / latching and relay with AC coil. The benefit is the possibility of combining various contact sets from 1 up to 6 poles, single and bifurcated contacts, different contact materials with a coil voltage range from 1,5 Vdc to 220 Vac. Cradle relays are available as dust protected and hermetically sealed versions, with plug in or solder terminals and are capable to switch currents up to 5 A. Forcibly guided (linked) contact sets optional. Dielectric strength 500 Vrms. Dimensions from approx. 19 x 24 to 19x35 mm board space and 30 mm height.

## Other Relays

We offer a variety of different relay families for maintenance and replacement purposes. These relays are up to 60 years old now, such as Card Relay SN (V23030 / V23031 series), Small General Purpose Relay (V23006 series), Small Polarized Relay (V23063 ... V23067 and V23163 ... V23167 series). Accessories like sockets, hold down springs, etc. optional.

**tyco**

**Electronics**

**AXICOM**



Tyco Electronics AXICOM Ltd.  
Seestrasse 295 - P.O. Box 220  
CH-8804 Au-Wädenswil / Switzerland  
Phone +41 1 782 9111  
Fax +41 1 782 9080  
E-mail: [axicom@tycoelectronics.com](mailto:axicom@tycoelectronics.com)



Tyco Electronics AMP GmbH  
Paulsternstrasse 26  
D-13629 Berlin / Germany  
Phone +49 30 386 38260  
Fax +49 30 386 38569  
E-mail: [axicom@tycoelectronics.com](mailto:axicom@tycoelectronics.com)



Tyco Electronics EC Trutnov s.r.o.  
Komenského 821  
CZ-541 01 Trutnov / Czech Republic  
E-mail: [axicom@tycoelectronics.com](mailto:axicom@tycoelectronics.com)

Tyco Electronics Corporation  
POB 3608,  
Harrisburg, PA 17105, USA  
Phone +1 800-522-6752