





ULTRAMINIATURE THIN LINE IS® PRESSURE TRANSDUCERS

LL-072 SERIES LLHT-072 SERIES

- Ideal For Flight Test & Wind Tunnel Applications
- Excellent Static And Dynamic Performance
- High Natural Frequency
- High Temperature Capabilities
-65°F To + 450°F (LLHT Series)
- Intrinsically Safe Leadless Technology  

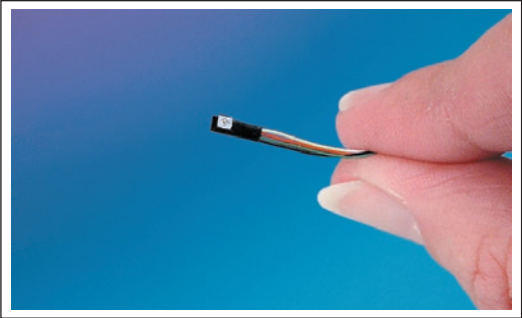

The LL/LLHT Series features Kulite's Patented Leadless Technology and demonstrates Kulite's ability to provide pressure transducers suited for adaptation into custom packages. These devices can be integrated into various test articles such as fan blades, engine nozzles of various types, etc. The features of these transducers include small foot print, high natural frequency, extreme resistance to vibration and shock, and wide temperature range.

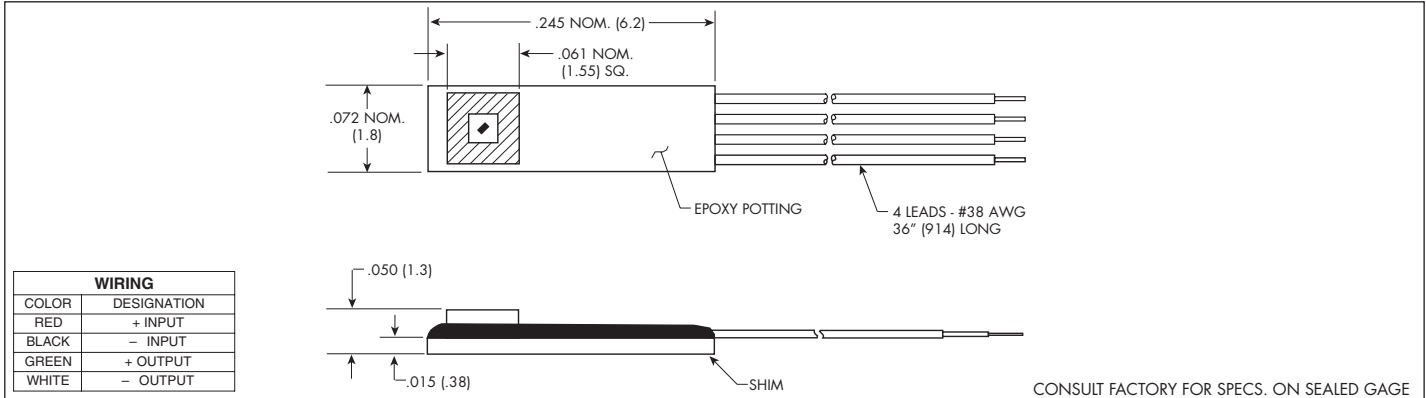

INPUT Pressure Range	1.7 25	3.5 50	7 100	17 250	35 BAR 500 PSI
Operational Mode	Absolute, Sealed Gage				
Over Pressure	2 Times Rated Pressure With No Change in Calibration				
Burst Pressure	3 Times Rated Pressure				
Pressure Media	All Nonconductive, Noncorrosive Liquids or Gases (Most Conductive Liquids and Gases - Please Consult Factory)				
Rated Electrical Excitation	10 VDC/AC				
Maximum Electrical Excitation	15 VDC/AC				
Input Impedance	1000 Ohms (Min.)				
OUTPUT Output Impedance	1000 Ohms (Nom.)				
Full Scale Output (FSO)	100 mV (Nom.)				
Residual Unbalance	± 5 mV (Typ.)				
Combined Non-Linearity, Hysteresis and Repeatability	± 0.1% FSO BFSL (Typ.), ± 0.5% FSO (Max.)				
Resolution	Infinitesimal				
Natural Frequency (KHz) (Typ.)	240	300	380	550	700
Acceleration Sensitivity % FS/g Perpendicular	5.0x10 ⁻⁴	3.0x10 ⁻⁴	1.5x10 ⁻⁴	1.0x10 ⁻⁴	6.0x10 ⁻⁵
Transverse	6.0x10 ⁻⁵	4.0x10 ⁻⁵	2.0x10 ⁻⁵	9.0x10 ⁻⁶	6.0x10 ⁻⁶
Insulation Resistance	100 Megohm Min. @ 50 VDC				
ENVIRONMENTAL Operating Temperature Range	LL SERIES -65°F to +250°F (-55°C to +120°C) LLHT SERIES -65°F to +450°F (-55°C to +235°C)				
Compensated Temperature Range	LL SERIES 80°F to +180°F (25°C to +80°C) Any 100°F Range Within The Operating Range on Request LLHT SERIES 80°F to +450°F (25°C to +235°C)				
Thermal Zero Shift	± 1% FS/100°F (Typ.)				
Thermal Sensitivity Shift	± 1% /100°F (Typ.)				
Steady Acceleration	10,000g. (Max.)				
Linear Vibration	10-20,000 Hz Sine, 100g. (Max.)				
PHYSICAL Electrical Connection	4 Leads 38 AWG 36" Long				
Weight	.2 Gram (Nom.) Excluding Leads				
Pressure Sensing Principle	Fully Active Four Arm Wheatstone Bridge Dielectrically Isolated Silicon on Silicon Patented Leadless Technology				

Note: Custom pressure ranges, accuracies and mechanical configurations available. Dimensions are in inches. Dimensions in parenthesis are in millimeters..

Continuous design support for your products <http://www.sensor-ic.com/> TEL:0755-83376549 FAX:0755-83376182 E-MAIL: szss20@163.com

KULITE SEMICONDUCTOR PRODUCTS, INC. • One Willow Tree Road • Leonia, New Jersey 07605 • Tel: 201 461-0900 • Fax: 201 461-0990 • <http://www.kulite.com>