

# OEM Relative pressure measuring cell 509

Pressure range  
0 ... 2.5 – 250 bar

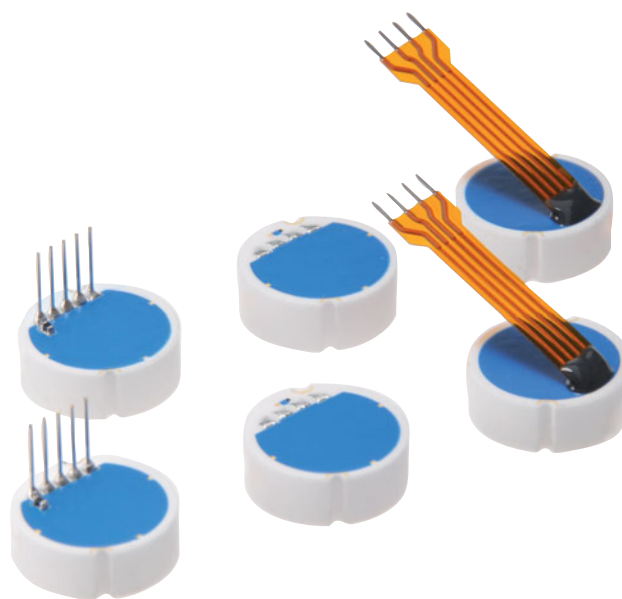

Type 509 pressure measuring cells are based on ceramic technology developed by Huba Control, and used for the last 15 years in millions of applications.

Due to the robust design of the ceramic cell there are no significant changes in the sensor characteristics when mounted by the customer. The pressure measuring cells are delivered either factory set or with TK zero point adjustment. You can choose between various versions including temperature measurement.

- Negligible temperature influence on accuracy
- No customer specific adjustment of zero point and temperature compensation necessary
- Easy mounting
- Overload secure up to rupture pressure

## Technical Overview

### Pressure range

Relative	0 ... 2.5 – 250 bar
----------	---------------------

### Operating conditions

Medium	Liquids and neutral gases	
Temperature	FPM	-15 ... +125 °C
	NBR	-25 ... +85 °C
	FPM spec.	-30 ... +150 °C
	Storage	-40 ... +130 °C
	in packaging	-40 ... +65 °C
Temperature influences in range -30 ... +125 °C	Zero point	max. ± 0.2% fs/10K with TC adjustment max. ± 1% fs/10K without TC adjustment
	Span	-0.12 ± 0.1% fs/10K
Overload / Rupture pressure <sup>1)</sup>	≤ 4 bar	3 x fs
	≥ 6 bar	2.5 x fs
Humidity protection	AHT, 20 days acc. DIN EN ISO 6270-2	

### Material in contact with the medium

Sensor	Ceramic Al <sub>2</sub> O <sub>3</sub> (96%)
Sealing material	FPM, NBR, FPM spec.

### Electrical data

Bridge impedance	10 kOhm ± 20%
Power supply	3 ... 30 VDC
Insulation voltage	2000 VDC
ESD-handling	Necessary
Electromagnetic compatibility	The product is designed exclusively for installation in equipment. The customer is responsible for CE conformity.

### Dynamic response

Response time	< 1 ms
Load cycle	< 100 Hz

### Electrical connector

Bondpads (AgPd) RAST 1.27	
Flexible connector RAST 2.54	Length 66 mm
	Length 28 mm
Pin connector	Length 9 mm
	Length 13 mm
Pin connector with temperature measuring (NTC 10kOhm ± 3%, β = 3800 K ± 3%)	Length 9 mm
	Length 13 mm

### Assembly / housing

According to recommendation of Huba Control with special assembly instructions
--

### Weight

~ 5 g
-------

### Packaging (multiple)

Cells with bondpads / Pin connector in covering box	5 Blister (96 pcs.)	480 pcs.
Cells with flexible connector in covering box	5 Blister (80 pcs.)	400 pcs.

## Accuracy

Parameter	Unit	
Zero point	mV / V	0.2 ± 0.2
Span at nominal pressure	mV / V	2.5 ± 1.5
Resolution	% fs	0.1
Linearity (BFSC) max.	% fs	± 0.3
Hysteresis and repeatability max.	% fs	± 0.2
Long term stability acc. to DIN EN 60770	% fs	± 0.5

Order code selection table		509	X	X	X	X	X
Relative pressure	axial sealed	9					
	radial sealed	R					
Pressure range <sup>1)</sup>	0 ... 2.5 bar		1	4			
	0 ... 4 bar		1	5			
	0 ... 6 bar		1	7			
	0 ... 10 bar		3	0			
	0 ... 16 bar		3	1			
	0 ... 25 bar		3	2			
	0 ... 40 bar		3	3			
	0 ... 60 bar		4	0			
	0 ... 100 bar		9	4	1		
	0 ... 160 bar		9	4	2		
	0 ... 250 bar		9	4	3		
▲ Full scale signal at these pressure							
Adjustment	Factory adjusted only zero point and TC <sup>2)</sup> zero point						1
	Factory adjusted only zero point						2
Electrical connection	Bondpads						1 G
	Flex connection Length: 28mm						1 K
	Flex connection Length: 66mm						1 L
	Pin connection Length: 9mm						2 M
	Pin connection Length: 13mm						2 N
	Pin connection with temperature measuring Length: 9mm						2 O
	Pin connection with temperature measuring Length: 13mm						2 P

**Accessories <sup>3)</sup>**

	Order number
O-ring FPM ≤ 60 bar	105598
O-ring NBR ≤ 60 bar	105145
O-ring FPM spec. ≤ 60 bar	109338
O-ring FPM ≥ 100 bar	105285
O-ring NBR ≥ 100 bar	104952
O-ring FPM spec. ≥ 100 bar	102321
Back-up ring teflon ≥ 100 bar	114660
Clam screw M20x1	112151
Screw insert for clamp screw	112187

Clamp screw

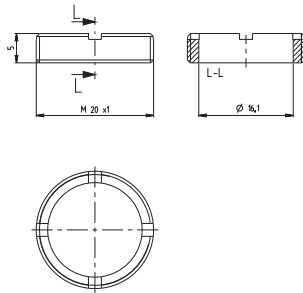

Screw insert

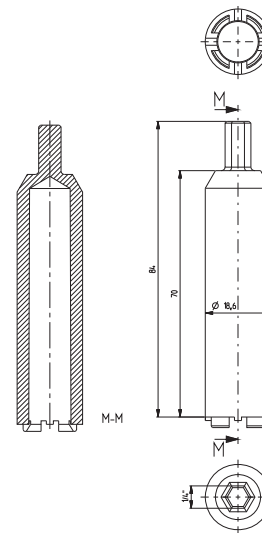

Recommended groove dimensions for o-ring Ø 10 x 1.5

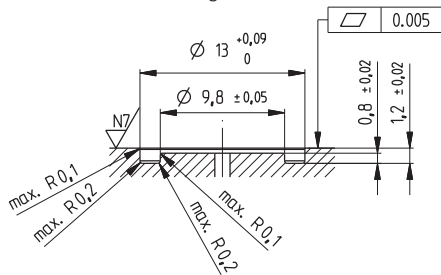

Flex connection

Bondpads

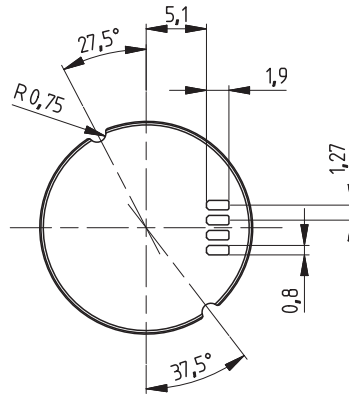
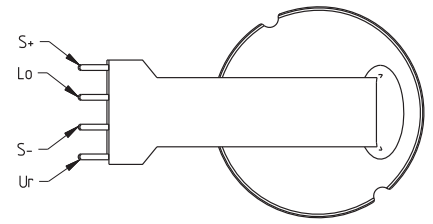
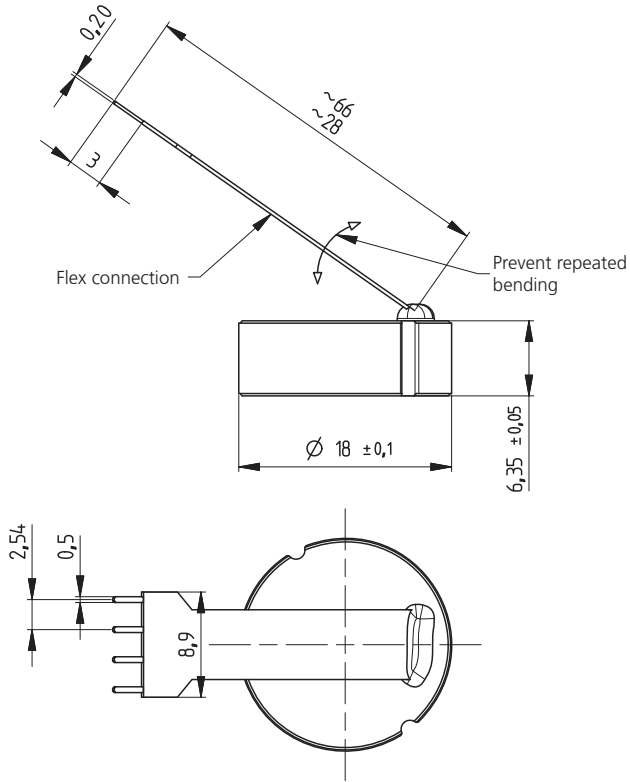

Pin connection 4 Pins

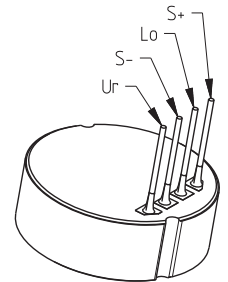
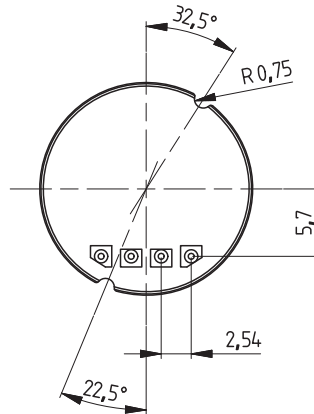
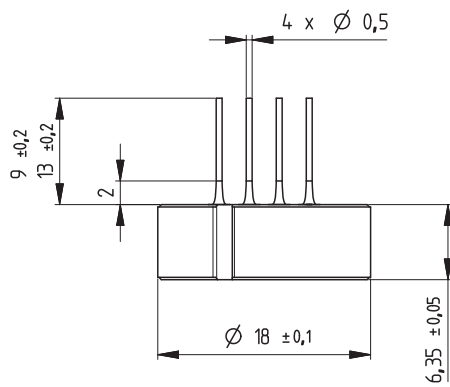

Pin connection 5 Pins with temperature measuring

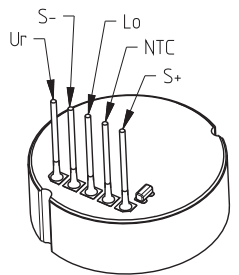
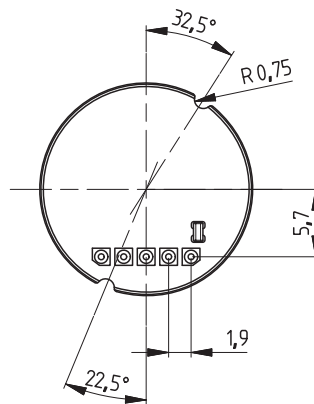
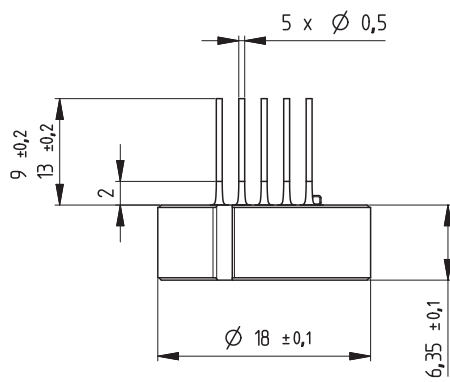

without NTC

with NTC

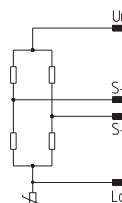
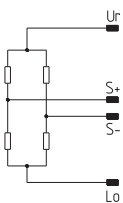

# Huba Control

FOR FINE PRESSURE AND FLOW MEASUREMENT

**Huba Control AG**  
**Headquarters**

Industriestrasse 17  
5436 Würenlos  
Telefon +41 (0) 56 436 82 00  
Telefax +41 (0) 56 436 82 82  
[info.ch@hubacontrol.com](mailto:info.ch@hubacontrol.com)

**Huba Control AG**  
**Niederlassung Deutschland**

Schlattgrabenstrasse 24  
72141 Walddorfhäslach  
Telefon +49 (0) 7127 23 93 00  
Telefax +49 (0) 7127 23 93 20  
[info.de@hubacontrol.com](mailto:info.de@hubacontrol.com)

**Huba Control SA**  
**Succursale France**

Rue Lavoisier  
Technopôle Forbach-Sud  
57602 Forbach Cedex  
Téléphone +33 (0) 387 847 300  
Télécopieur +33 (0) 387 847 301  
[info.fr@hubacontrol.com](mailto:info.fr@hubacontrol.com)

**Huba Control AG**  
**Vestiging Nederland**

Hamseweg 20A  
3828 AD Hoogland  
Telefoon +31 (0) 33 433 03 66  
Telefax +31 (0) 33 433 03 77  
[info.nl@hubacontrol.com](mailto:info.nl@hubacontrol.com)

**Huba Control AG**  
**Branch Office United Kingdom**

Unit 13 Berkshire House  
County Park Business Centre  
Shrivenham Road  
Swindon Wiltshire SN1 2NR  
Phone +44 (0) 1993 776667  
Fax +44 (0) 1993 776671  
[info.uk@hubacontrol.com](mailto:info.uk@hubacontrol.com)

[www.hubacontrol.com](http://www.hubacontrol.com)