

APPLICATION NOTE

REFERENCE DESIGN: LOW COST COMPASS

ABSTRACT

Using Honeywell's HMC1052 Anisotropic Magneto-Resistive (AMR) sensor circuit, a small size and low cost compass circuit design can be implemented. This reference design is aimed at product developers who desire a basic compass function using off-the-shelf analog and digital components. Together with a microcontroller incorporating dual Analog-to-Digital Converter (ADC) inputs, a compassing circuit can be assembled with the HMC1052 2-axis sensor, a low voltage dual op-amp, and a few generic discrete components. While not a full featured 3-axis, tilt compensated compass design; this reference design can be used on level platforms or user leveled systems such a wrist watches.

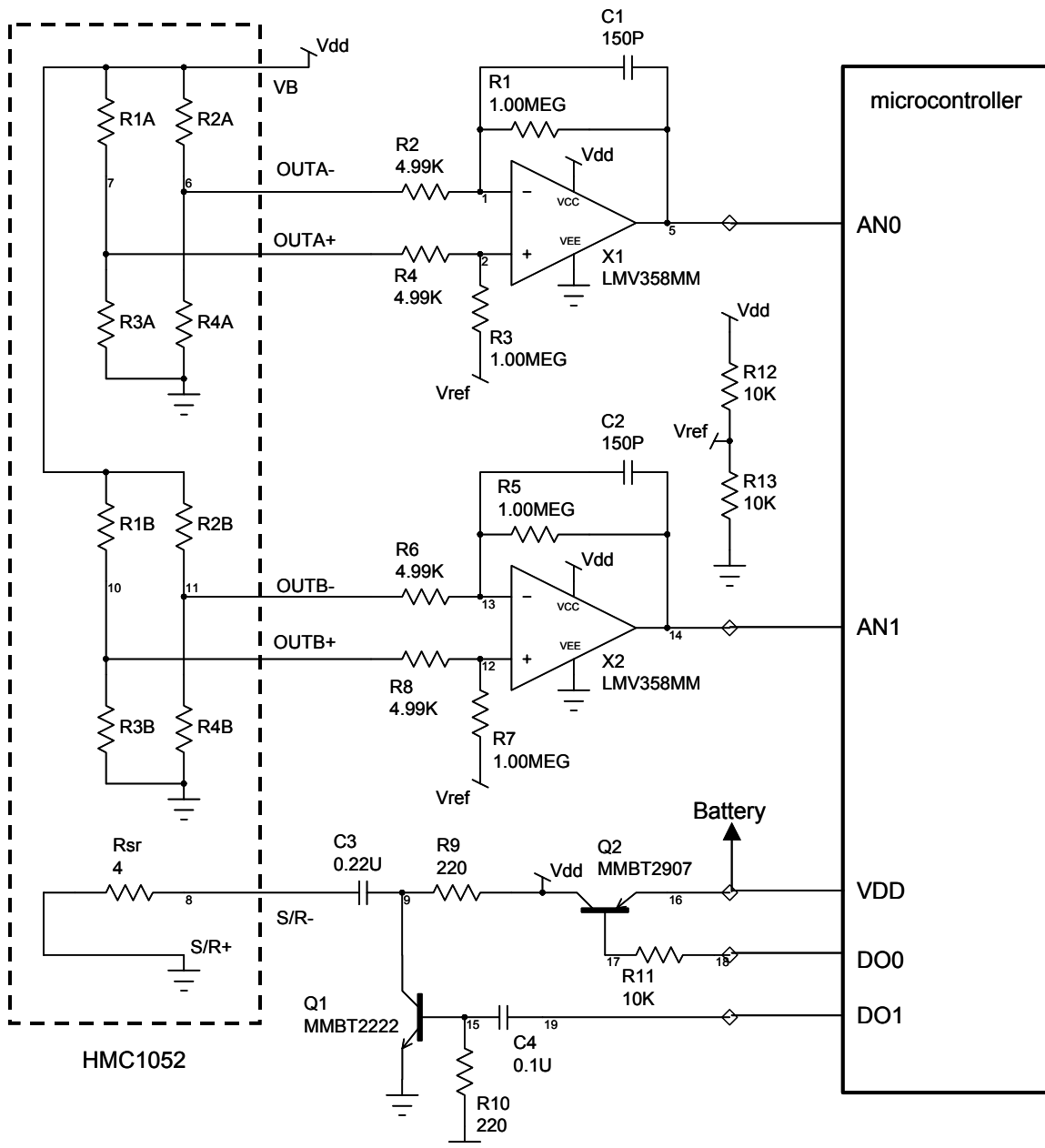

Figure 1

## CIRCUIT DESCRIPTION

The HMC1052 2-Axis magnetic sensor shown in the dashed box in Figure 1 includes two wheatstone bridge networks depicted as RA and RB. Each resistance element in the bridges is nominally 1100 ohms with an average magnetic field sensitivity of 1 milli-volt per gauss per volt applied on the bridge. With the two bridge elements oriented orthogonal to each other, each bridge has a sensitive axis' to break the earth's magnetic field into X and Y vector components. The bridge elements provide a balanced signal output biased on half the supply voltage (Vdd). Any imbalance across the outputs (OUTA-, OUTA+, OUTB-, and OUTB+) will be due to earth's magnetic field plus the manufacturing tolerance error on the bridges called bridge offset.

The sensor bridge offset voltages can be found simply by placing the compass circuit in a magnetically shielded enclosure and measuring the voltage difference across each bridge's output pins. Typically this offset is a fraction of a milli-volt for every volt applied across the bridge. In this reference design, a nominal voltage range of 2.7 to 3.6 volts is expected, representing a typical lithium battery voltage range.

Within the HMC1052 sensor, a spiral of metal is placed below each bridge element to optionally perform a "set" or "reset" function. This set/reset function allows the compass to re-align the permalloy thin film resistive elements to factory conditions. By placing a large current briefly on the metal strap that spirals through both sensor elements, the current pulse creates a localized magnetic field that re-aligns the permalloy films. The set/reset strap is represented by resistor Rsr and has a 3 to 5 ohm resistance value.

The output voltages of each sensor bridge are next fed into instrumentation amplifier stages to perform the difference measurement and to amplify the result about 200 times for conversion into a digital number for both sensor outputs. In this example, a dual operational amplifier (op-amp) represented by X1 and X2 is chosen to be a National Semiconductor LMV358MM part. The LMV358MM can be substituted with other similar op-amps, with priorities being low voltage compatible, low cost, small package size, and modest current consumption.

Op-amp stages X1 and X2 are surrounded by resistor elements R1 through R4 and R5 through R8 respectively. These resistors setup the amplification ratio of 200 by using input resistors of 4.99 kilo-ohms and feedback resistors of 1 Mega-ohms (1Meg/4.99k = 200). By choosing the input resistors to be four to ten times the bridge element resistances, the bridges are minimally loaded and the offset errors induced by the

op-amp stages are minimized. These resistors should be 1% tolerance parts for best noise rejection and offset minimization.

Capacitors C1 and C2 are chosen based on the value of the feedback resistors and the circuit measurement bandwidth desired. In this design, they are chosen to be 150 pico-farads for just over a 1kHz bandwidth. The 1kHz bandwidth is small enough prevent EMI/RFI amplification, and yet plenty fast enough to allow many measurements to be accomplished in the span of one second.

Resistors R12 and R13 perform a simple supply splitting network (rail splitting) to create a half supply voltage reference (Vref) to supply the instrumentation amplifier circuits composed of X1, X2, C1, C2, and resistors R1 through R8. The values for R12 and R13 are required to be identical and somewhat arbitrary. By choosing them at 10 kilo-ohms, they resist pulling Vref away from the half supply point by being 100 times lower than the feedback resistor loads, but still being large enough to not appreciably draw much current from the supply voltage source (e.g. coin cell batteries). The Vref point may look ripe for capacitive bypassing for increased noise rejection, but this is not done as additional capacitance would slow the op-amp stabilization time for "snapshot" compassing measurements. The rationale for snapshot-ing compass measurements is to reduce circuit energy consumption by turning on the sensors and amplifier circuits briefly and leaving a majority of the time in the off state.

Transistor Q1, resistors R9 and R10, and capacitors C3 and C4 form a "set" circuit for driving high current pulses into the HMC1052 set/reset strap resistance (Rsr). A microcontroller performs the control portion of this circuit by providing a digital output pin (DO1) in a normally low logic state. This normal state allows transistor Q1 to be "off" (cutoff), and permits capacitor C3 to charge up to nearly full supply voltage and leaves capacitor C4 nearly fully discharged (zero volts). When the DO1 switches from low to high logic state, Resistor R10 and capacitor C4 create a positive voltage spike to briefly turn Q1 fully on, placing the fully charged C3 in a closed circuit with Rsr. The result is a current pulse of over a half an ampere flowing through Q1, C3 and Rsr to create the "set" magnetic field for bridge element re-alignment. Resistor R9 is chosen to be around 220 ohms to recharge C3 after the digital output transition and to limit the maximum recharge current draw to small battery capable levels.

Transistor Q2 and resistor R11 create an electronic switch to toggle the compass circuit supply (Vdd) on and off. Another digital output pin (DO0) is normally in a high logic state keeping Q2 cutoff and preventing the

battery positive contact from energizing the compass circuit components. When DO0 switches to its low logic state, resistor R11 turns Q2 fully on to permit many milliamperes of current to flow into the sensors, op-amps, and set circuits.

## OPERATIONAL DETAILS

With the compass circuitry fully powered up, sensor bridge A composed the R1A, R2A, R3A, and R4A permalloy resistive elements creates a voltage difference across OUTA- and OUTA+ that is then amplified 200 times and presented to microcontroller analog input AN0. Similarly, bridge B permalloy resistive elements R1B, R2B, R3B, and R4B create a voltage difference across OUTB- and OUTB+ that is amplified 200 times and presented to microcontroller analog input AN1. These analog voltages at AN0 and AN1 can be thought of as “X” and “Y” vector representations of the magnetic field.

To get these X and Y values extracted, the voltages at AN0 and the AN1 are to be digitized by the microcontroller’s onboard Analog-to-Digital Converter (ADC). Depending on the resolution of the ADC, the resolution of the Compass is set. Typically compasses with one degree increment displays will have 10-bit or greater ADCs, with 8-bit ADCs more appropriate for basic 8-cardinal point (North, South, East, West, and the diagonal points) compassing. Individual microcontroller choices have a great amount of differing ADC implementations, and there may be instances where the ADC reference voltage and the compass reference voltage can be shared. The point to remember is that the analog voltage outputs are referenced to half the supplied bridge voltage and amplified with a similar reference.

The most often asked question on AMR compass circuits is how frequent the set/reset strap must be pulsed. The answer for most low cost compasses is fairly infrequently to the range of once per second to as long as once per compass feature selection by the user. While the set circuit draws little energy on a per pulse basis, a constant one pulse per second rate could draw down a fresh watch battery in less than a year. In the other extreme of one “set” pulse upon the user manually requesting a compass heading, negligible battery life impact could be expected. From a common sense standpoint, the set pulse interval should be chosen as the shortest time a user could withstand an inaccurate compass heading after exposing the compass circuit to nearby large magnetic sources such as speaker magnets, welding cables, and CRT deflection coils. Typical automatic set intervals for low cost compasses could be once per 10 seconds to one per hour depending on battery energy capacity. Provision for a user commanded “set”

function may be a handy alternative to periodic or automatic set routines.

In portable consumer electronic applications like compass-watches, PDAs, and wireless phones; choosing the appropriate compass heading data flow has a large impact on circuit energy consumption. For example, a one heading per second update rate on a sport watch could permit the compass circuit to remain off to nearly 99 percent of the life of the watch with just 10 millisecond measurement snapshots per second and a one per minute set pulses for perming correction. The HMC1052 sensors have a 5 MHz bandwidth in magnetic field sensing, so the minimum snapshot measurement time is derived principally by the settling time of the op-amps plus the sample-and-hold time of the microcontroller’s ADCs.

In some “gaming” applications in wireless phones and PDAs, more frequent heading updates permits virtual reality sensor inputs for software reaction. Typically these update rates follow the precedent set more than a century ago by the motion picture industry (“Movies”) at 20 updates or more per second. While there is still some value in creating off periods in between these frequent updates, some users may choose to only switch power on the sensor bridges exclusively and optimize the remainder of the circuitry for low power consumption.

## HEADING (COMPASSING) ALGORITHM

Once the voltages at the AN0 and AN1 inputs to the microcontroller are stable and the on-board ADC has sampled the inputs, the beginning of the heading computation can begin. The first part of the heading computation is to scale the input voltages into ADC “counts” and reference the counts from a zero magnetic field value. For example, a 10-bit ADC has 1024 counts spread over most of its power supply voltage range. With a nominal 3-volt supply ( $V_{dd} = 3V$ ), Each count would be about 2.9 millivolts with count 512 equal to  $V_{ref}$  at 1.5 volts.

The zero magnetic field ADC count would ideally be 512 for both AN0 and AN1 inputs, but in reality the counts will have some offset from one or more error sources. These sources must be subtracted from the nominal 512-count reference level. If we call the AN0 counts “X” and the AN1 counts “Y”, then circuit offset correction values  $X_{co}$  and  $Y_{co}$  are measured in the factory and stored in the microcontroller’s memory. Equations like:

$$X_{co} = X - 512, \quad Y_{co} = Y - 512$$

Are the first correction factors required.

The next data massaging is to include ferrous content correction factors from the last user calibration routine. Nearby ferrous materials may create distortions in the earth's magnetic field at the sensor bridges, and will require both offset values and scale factor values for both X and Y counts. These values can be denoted as Xoff, Yoff, Xsf, and Ysf. Before the scale factors can be applied, the Vref count level (e.g. 512) also must be removed to arrive at numbers that are bi-directional from the normalized "0" point. Thus the equations for true heading X and Y values are:

$$X_h = [(X - 512 - X_{co}) * (X_{sf})] - X_{off}$$

$$Y_h = [(Y - 512 - Y_{co}) * (Y_{sf})] - Y_{off}$$

Once these true heading count values are determined, the compass heading (azimuth) is computed by applying the formula:

$$\text{Heading} = \arctan (Y_h/X_h)$$

To accomplish this using a memory limited microcontroller, a memory map is employed to do the arc-tangent function as a look-up table. The fraction of Yh divided by Xh is computed and then compared to a memory map containing the full resolution of compass headings available. For example, a one-degree compass will have a memory map of 90 locations plus knowing the positive/negative signs of Xh and Yh, to allow 360 one-degree headings to be chosen. Thus the heading quotient is matched to the closest memory mapped number. Special case situations when Xh equals zero (i.e. perfectly east or west) also have to be detected before the quotient computation or an infinity error will result. For more detail on arc-tangent azimuth computations, please see the white papers entitled "Applications of Magnetoresistive Sensors in Navigation Systems", or "Applications of Magnetic Sensors for Low Cost Compass Systems" at the [magneticsensors.com](http://magneticsensors.com) website.

## COMPASS CALIBRATION

In the previous section, the values Xoff, Yoff, Xsf, and Ysf are calibration factors for "hard-iron" distortions of the earth's magnetic field at the sensors. Typically these distortions come from nearby magnetized components. Soft-iron distortions are more complex to factor out of heading values and are generally left out for low cost compassing applications. Soft-iron distortion arises from magnetic fields bent by unmagnetized ferrous materials either very close to the sensors or large in size.

To derive the calibration factors, the sensor assembly and its fixed platform (e.g. watch/human, boat, auto, etc.) are turned at least one complete rotation as the

compass electronics collects many continuous readings. The speed and rate of turn are based on how quickly the microcontroller can collect and process Xh and Yh data during the calibration routine. A good rule of thumb is to collect readings every few degrees by either asking the user to make a couple rotations or by keeping in the rotation(s) slow enough to collect readings of the correct rate of turn.

The Xh and Yh readings during calibration are done with Xoff and Yoff at zero values, and Xsf and Ysf at unity values. The collected Xh and Yh values are then tabulated to find the min and max of both X and Y. At the end of the calibration session, the Xmax, Ymax, Xmin, and Ymin values are converted to the following:

$X_{sf} = 1$  or  $(Y_{max} - Y_{min}) / (X_{max} - X_{min})$ , whichever is greater

$Y_{sf} = 1$  or  $(X_{max} - X_{min}) / (Y_{max} - Y_{min})$ , whichever is greater

$$X_{off} = [(X_{max} - X_{min})/2 - X_{max}] * X_{sf}$$

$$Y_{off} = [(Y_{max} - Y_{min})/2 - Y_{max}] * Y_{sf}$$

## SUMMARY

This Low Cost Compass Reference Design is created to show the design process and ease of use of off-the-shelf components in an electronic compass. Readers should feel free to substitute components and challenge design constraints that do not match their end-product priorities. For further design assistance, use the data and application information on the [magneticsensors.com](http://magneticsensors.com) website or call the Honeywell Solid State Electronics Center for further assistance.

900299 10-02 Rev –