

# Limit and Enclosed Switches

## Application Information

应用控制 http://www.sensor-ic.com/ TEL:0755-83376549 FAX:0755-83376182 E-MAIL:szss20@163.com

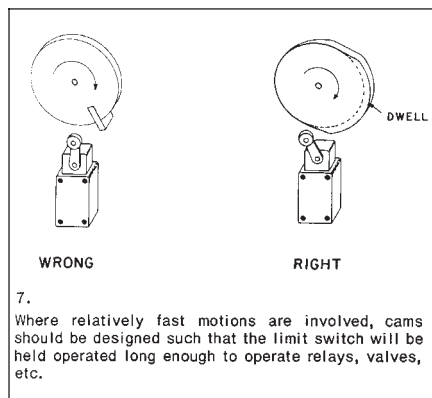

7. Where relatively fast motions are involved, cams should be designed such that the limit switch will be held operated long enough to operate relays, valves, etc.

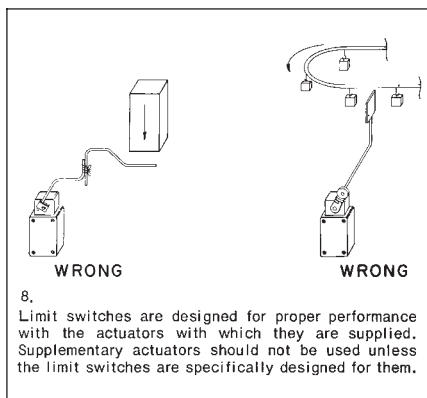

8. Limit switches are designed for proper performance with the actuators with which they are supplied. Supplementary actuators should not be used unless the limit switches are specifically designed for them.

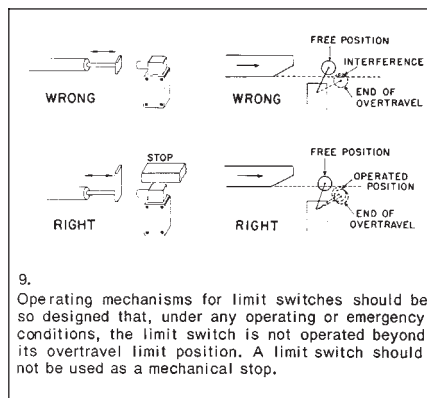

9. Operating mechanisms for limit switches should be so designed that, under any operating or emergency conditions, the limit switch is not operated beyond its overtravel limit position. A limit switch should not be used as a mechanical stop.

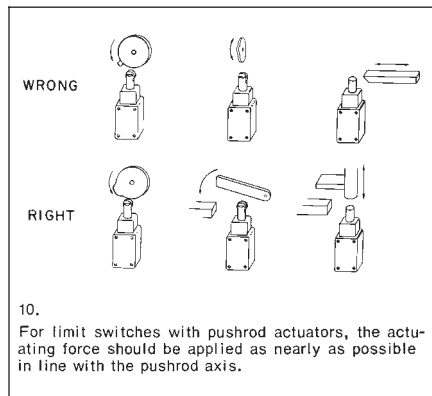

10. For limit switches with pushrod actuators, the actuating force should be applied as nearly as possible in line with the pushrod axis.

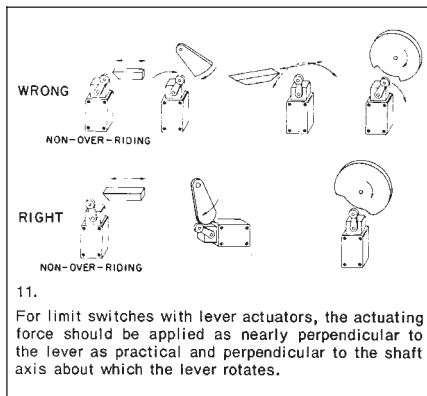

11. For limit switches with lever actuators, the actuating force should be applied as nearly perpendicular to the lever as practical and perpendicular to the shaft axis about which the lever rotates.

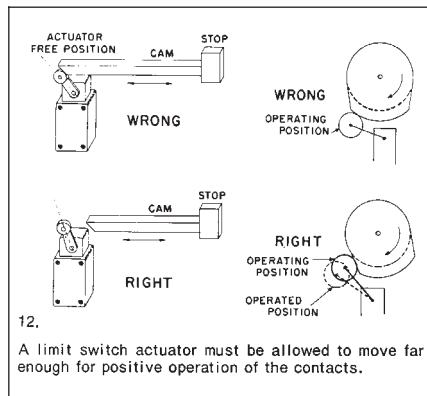

12. A limit switch actuator must be allowed to move far enough for positive operation of the contacts.

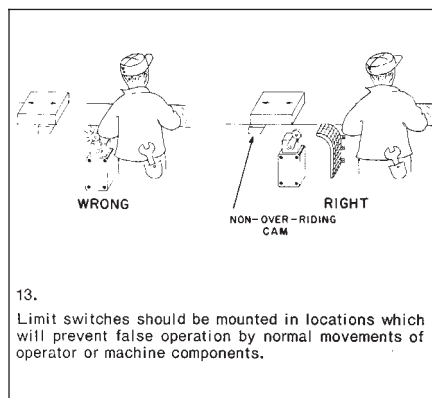

13. Limit switches should be mounted in locations which will prevent false operation by normal movements of operator or machine components.

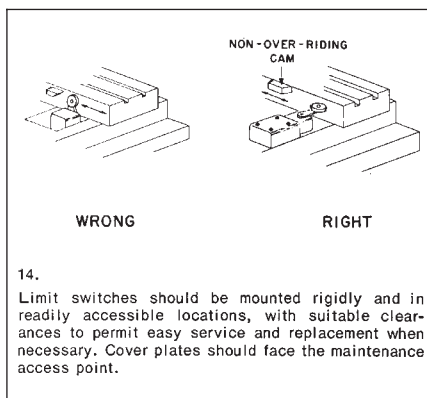

14. Limit switches should be mounted rigidly and in readily accessible locations, with suitable clearances to permit easy service and replacement when necessary. Cover plates should face the maintenance access point.

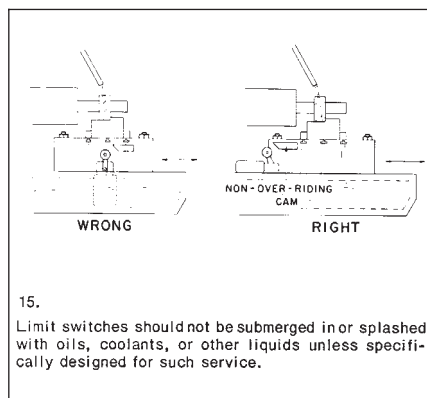

15. Limit switches should not be submerged in or splashed with oils, coolants, or other liquids unless specifically designed for such service.

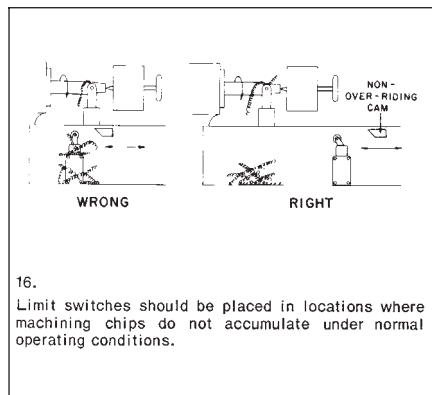

16. Limit switches should be placed in locations where machining chips do not accumulate under normal operating conditions.

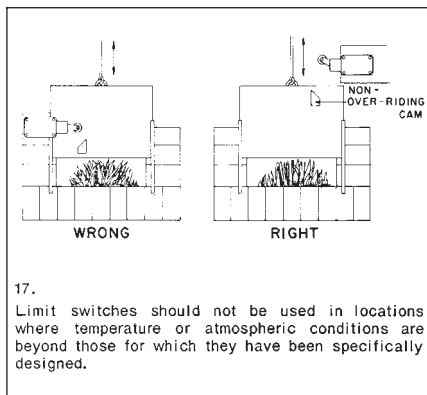

17. Limit switches should not be used in locations where temperature or atmospheric conditions are beyond those for which they have been specifically designed.

Limit/Enclosed