

TGS 6810 - for the detection of Methane and LP Gas

Features:

- * Linear output
- * Compact size
- * Small sensitivity to alcohol
- * Sensitive to both methane and LP gas
- * Meets RoHS requirements

Applications:

- * Residential LNG and LPG alarms
- * Detectors for LNG and LPG

The **TGS6810** catalytic type gas sensor, which can detect both methane and LP gas, has been developed for residential gas detection. Combining Figaro's 35+ years of experience in catalyst materials technology with its advanced micro fabrication technology, Figaro can produce the most advanced compact catalytic sensors whose durability, stability, quick response, and linear output make them ideal for detecting many combustible gases.

As the sensor possesses an adsorbent inside its sensor cap, its cross sensitivity to alcohol is much smaller than traditional catalytic type sensors. In addition, TGS6810 is more durable against silicone compounds than traditional catalytic type sensors.



The figure below represents typical sensitivity characteristics, all data having been gathered at standard test conditions (see reverse side of this sheet). The Y-axis is indicated as *sensor output sensitivity-- ΔV_{out} (mV)*:

$$\Delta V_{out} = V_{out \text{ in gas}} - V_{out \text{ in air}}$$

The figure below represents typical temperature dependency characteristics at 65%RH. Again, the Y-axis is indicated as *sensor output sensitivity-- ΔV_{out} (mV)*:

$$\Delta V_{out} = V_{out \text{ in gas}} - V_{out \text{ in air}}$$

Sensitivity Characteristics:

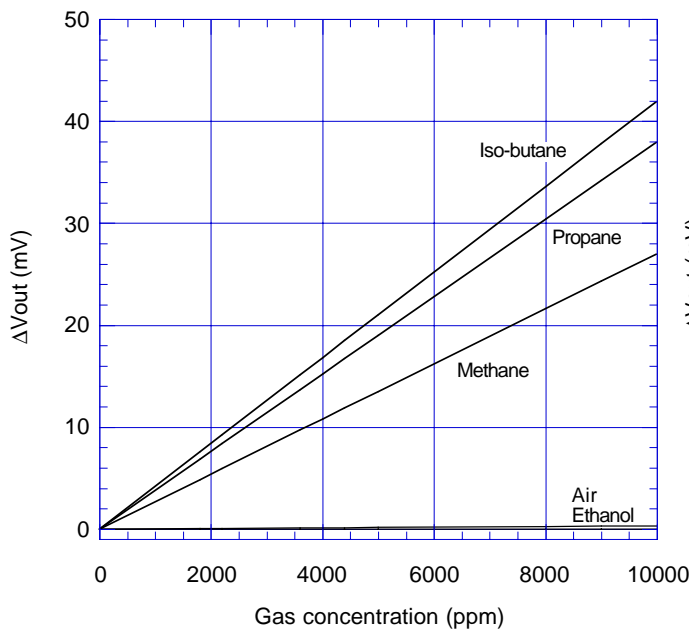

Temperature Dependency:

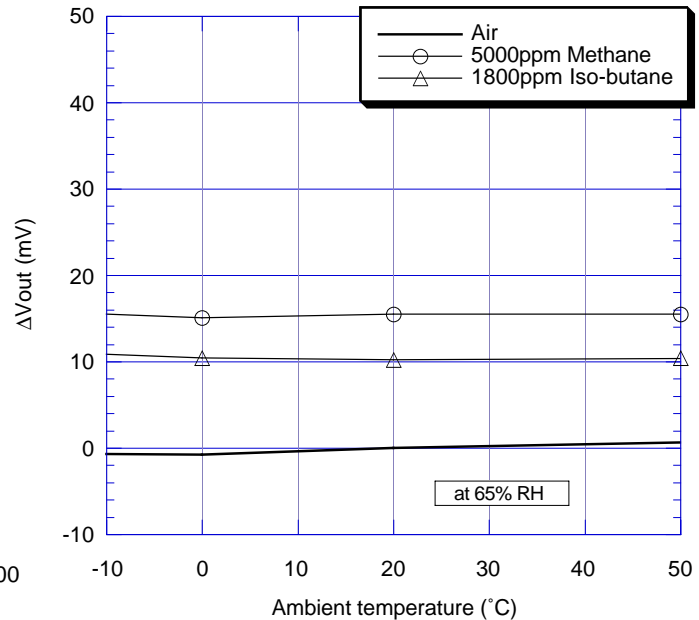

Basic Measuring Circuit:

The TGS6810 is comprised of two elements: 1) element (D) which is sensitive to combustible gases and 2) a reference element (C) which is not sensitive to combustible gases. These elements are installed into a "Wheatstone Bridge". A variable resistor should be adjusted so that the bridge will produce a stable baseline signal when in an

environment free of combustible gases. When combustible gases are present, they will be combusted on the detecting element, causing its temperature to rise. Accordingly the resistance of this element will increase. This results in an "out-of-balance" signal across the bridge and a corresponding change in output voltage which can be measured.

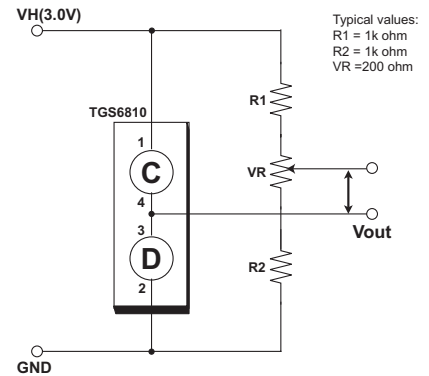

Specifications

Model number		TGS 6810		
Sensing element type		Catalytic		
Target gases		Hydrogen, methane, iso-butane		
Typical detection range		0~100%LEL of each gas		
Standard circuit conditions	Operating Voltage	3.0±0.1V AC/DC		
Electrical characteristics under standard test conditions	Heater current	175mA (typical)		
	Heater power consumption	525mW (typical)		
	Zero offset	±35mV		
	Output sensitivity (ΔVout)	methane	12~18mV in 5000ppm	
		iso-butane	7~11mV in 1800ppm	
Response time (90%)	≤15 sec.			
Standard test conditions	Test gas conditions	Hydrogen/methane/iso-butane in air at 20±2°C, 65±5%RH		
	Circuit conditions	3.0±0.05V AC/DC		
	Conditioning period before test	≤30 sec.		
Operating conditions		-10~+50°C, ≤99%RH (w/o dew condensation)		
Storage conditions		-10~+60°C, ≤99%RH (w/o dew condensation)		

Structure and Dimensions:

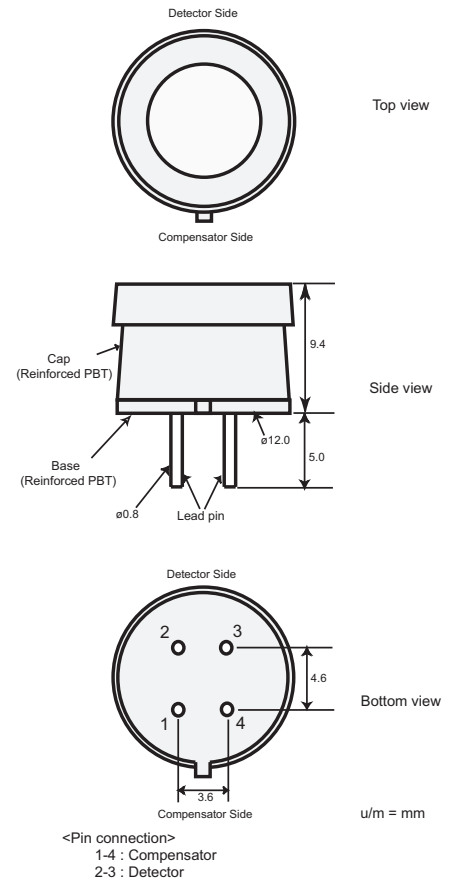

FIGARO ENGINEERING INC.

1-5-11 Senba-nishi
Mino, Osaka 562 JAPAN
Phone: (81)-72-728-2561
Fax: (81)-72-728-0467
www.figaro.co.jp
email: figaro@figaro.co.jp