



# TGS 4161 - for the detection of Carbon Dioxide

## Features:

- \* High selectivity to CO<sub>2</sub>
- \* Compact size
- \* Low dependency on humidity
- \* Long life and low cost
- \* Low power consumption

## Applications:

- \* Indoor air quality control
- \* CO<sub>2</sub> monitors

**TGS4161** is a new solid electrolyte CO<sub>2</sub> sensor which offers miniaturization and low power consumption. A range of 350~10,000ppm of carbon dioxide can be detected by TGS4161, making it ideal for indoor air control applications.

The CO<sub>2</sub> sensitive element consists of a solid electrolyte formed between two electrodes, together with a printed heater (RuO<sub>2</sub>) substrate. By monitoring the change in electromotive force (EMF) generated between the two electrodes, it is possible to measure CO<sub>2</sub> gas concentration.

The top of the sensor cap contains adsorbent (zeolite) for the purpose of reducing the influence of interference gases.

**TGS4161** exhibits a linear relationship between  $\Delta$ EMF and CO<sub>2</sub> gas concentration on a logarithmic scale. The sensor displays good long term stability and shows excellent durability against the effects of high humidity.

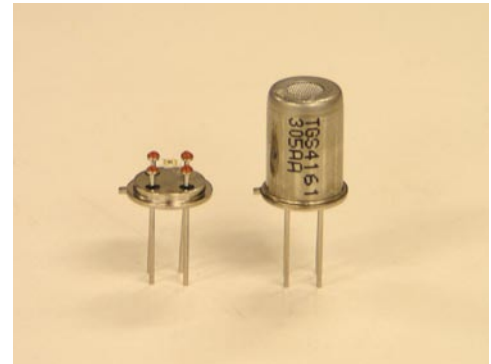

The figure below represents typical sensitivity characteristics of TGS4161. The Y-axis is indicated as  $\Delta$ EMF which is defined as follows:

$$\Delta\text{EMF} = \text{EMF}_1 - \text{EMF}_2$$

where  
 EMF<sub>1</sub> = EMF in 350 ppm CO<sub>2</sub>  
 EMF<sub>2</sub> = EMF in listed gas concentration

The figure below shows typical humidity dependency of TGS4161. Again, the Y-axis is indicated as  $\Delta$ EMF which is defined as follows:

$$\Delta\text{EMF} = \text{EMF}_1 - \text{EMF}_2$$

where  
 EMF<sub>1</sub> = EMF in 350 ppm CO<sub>2</sub>  
 EMF<sub>2</sub> = EMF in 1000ppm CO<sub>2</sub>

### Sensitivity Characteristics:

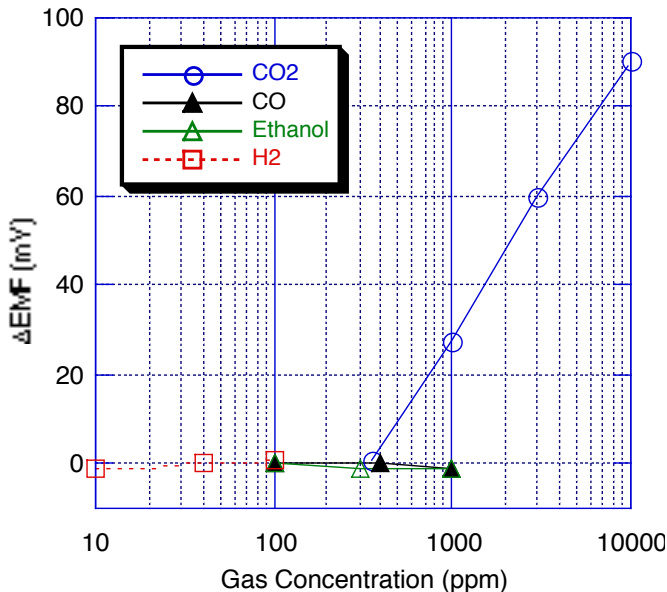

### Humidity Dependency:

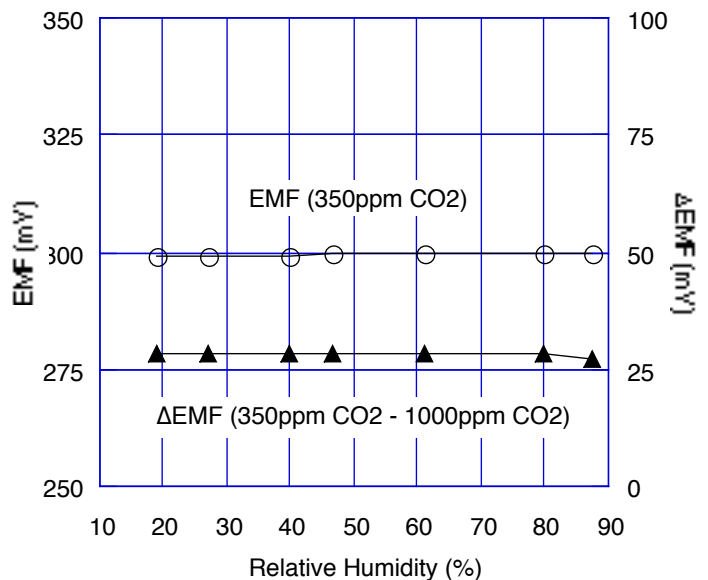

**IMPORTANT NOTE:** OPERATING CONDITIONS IN WHICH FIGARO SENSORS ARE USED WILL VARY WITH EACH CUSTOMER'S SPECIFIC APPLICATIONS. FIGARO STRONGLY RECOMMENDS CONSULTING OUR TECHNICAL STAFF BEFORE DEPLOYING FIGARO SENSORS IN YOUR APPLICATION AND, IN PARTICULAR, WHEN CUSTOMER'S TARGET GASES ARE NOT LISTED HEREIN. FIGARO CANNOT ASSUME ANY RESPONSIBILITY FOR ANY USE OF ITS SENSORS IN A PRODUCT OR APPLICATION FOR WHICH SENSOR HAS NOT BEEN SPECIFICALLY TESTED BY FIGARO.

**Basic Measuring Circuit:**

The TGS4161 sensor requires heater voltage (V<sub>H</sub>) input. The heater voltage is applied to the integrated heater in order to maintain the sensing element at a specific temperature which is optimal for sensing. Electromotive force (EMF) of the sensor should be measured using a high impedance (>100 GΩ) operational amplifier with bias current < 1pA (e.g. Texas Instruments' model #TLC271). Since the solid electrolyte type sensor

functions as a kind of battery, the EMF value itself would drift using this basic measuring circuit. However, the change of EMF value (ΔEMF) shows a stable relationship with the change of CO<sub>2</sub> concentration. Therefore, in order to obtain an accurate measurement of CO<sub>2</sub>, a special microprocessor for signal processing should be used with TGS4161. Figaro can provide a special evaluation sensor module (AM-4-4161) for TGS4161.

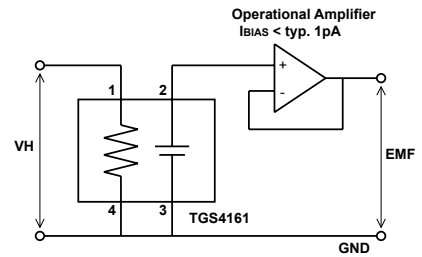

**Specifications:**

Model number		TGS 4161		
Sensing element type		Solid electrolyte		
Target gases		Carbon dioxide		
Typical detection range		350 ~ 10,000 ppm		
Electrical characteristics	Heater resistance	R <sub>H</sub>	70 ± 7Ω at room temp.	
	Heater current	I <sub>H</sub>	approx. 50mA	
	Heater power consumption	P <sub>H</sub>	approx. 250mW	
	Electromotive force	EMF	220~490mV in 350ppm CO <sub>2</sub>	
	Sensitivity	ΔEMF	44~72mV	EMF(350ppm CO <sub>2</sub> )-EMF(350ppm CO <sub>2</sub> )
	Heater voltage	V <sub>H</sub>	5.0 ± 0.2V (DC)	
Sensor characteristics	Response time	approx. 1.5 min. (to 90% of final ΔEMF value)		
	Measurement accuracy	approx. ±20% at 1,000ppm CO <sub>2</sub>		
Operating conditions		-10~50°C, 5~95%RH		
Storage conditions		-20~60°C, 5~90%RH (store in moisture proof bag with silica gel)		
Standard test conditions	Test gas condition	CO <sub>2</sub> in air at 20±2°C, 65±5%RH		
	Circuit condition	V <sub>H</sub> = 5.0±0.05V DC		
	Conditioning period before test	12 hours or longer		

**Structure and Dimensions:**

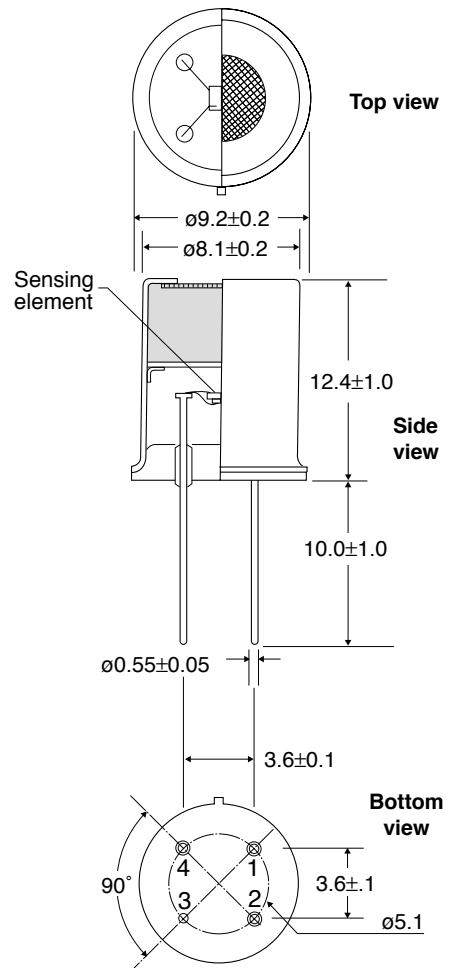

**Sensing Element Structure:**

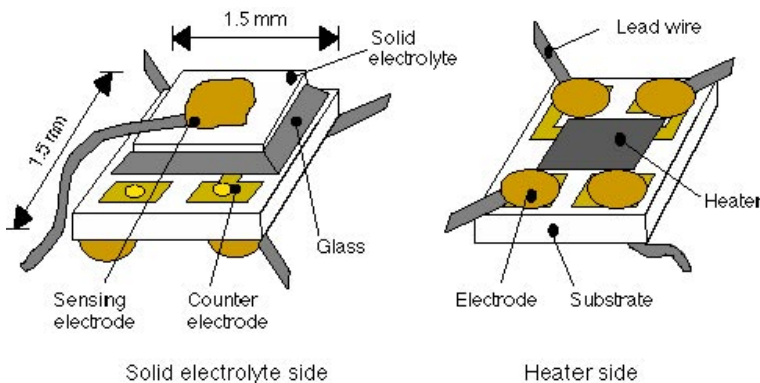

- Pin Connection:**  
 1. Heater (+)  
 2. Counter electrode (+)  
 3. Sensing electrode (-)  
 4. Heater (-)

u/m = mm

For information on warranty, please refer to Standard Terms and Conditions of Sale of Figaro USA Inc.

**FIGARO USA, INC.**  
 121 S. Wilke Rd. Suite 300  
 Arlington Heights, IL 60005 USA  
 Phone: (1)-847-832-1701  
 Fax: (1)-847-832-1705  
 email: figarousa@figarosensor.com