

# Dual Element Detector LHi 968

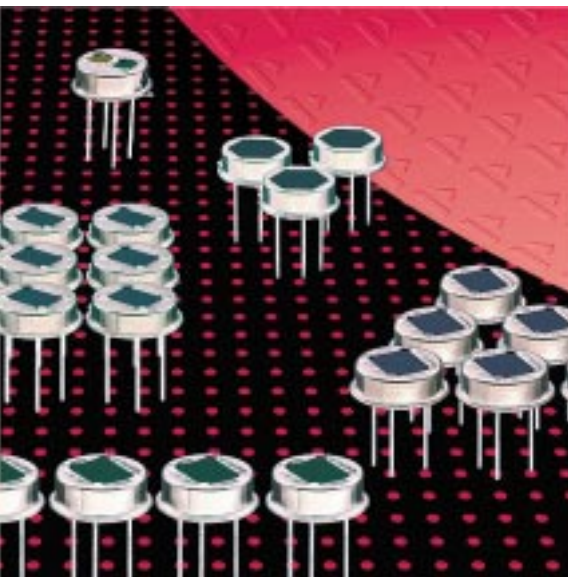

## High End Dual Element Detector

## Special RFI Protection

## Designed for PIR Alarms

The **LHi 968** pyroelectric infrared-detector series is specially designed for Intrusion Alarm applications. It includes a dual element pyroelectric ceramic with FET in source follower connection and RF protection by a resistor and additional capacitor.

This detector is available in **TO-5** housing with an infrared filter which protects the elements from strong white light disturbance. It offers high responsivity with excellent common mode performance (match) and low noise.

Parameters	LHi 968			
	min	typical	max	units condition
<b>Element size</b>	2 x 1		mm <sup>2</sup>	(2 elements)
<b>Responsivity</b>	3 300	3800	V/W	100°C, 1 Hz
<b>Match</b>	1 10		%	
<b>Noise</b>	20 50		µVpp	25°C, 0,3...10Hz
<b>Offset Voltage</b>	0,2	1,5	V	25°C, R <sub>s</sub> =47kΩ
<b>NEP</b>	7,5x10 <sup>-10</sup>	28x10 <sup>-10</sup>	W √Hz	1Hz Bw, 100°C, 1 Hz
<b>D*</b>	5x10 <sup>7</sup>	19x10 <sup>7</sup>	cm √Hz/W	1Hz Bw, 100°C 1 Hz
<b>Output Impedance</b>	5 10		kΩ	R <sub>s</sub> =47kΩ, 25°C
<b>Operating Voltage</b>	2	15	V	R <sub>s</sub> =47kΩ, 25°C
<b>Field of View, horizontal</b>	100°		unobstructed	
<b>vertical</b>	100°		unobstructed	
<b>Operating Temperature</b>	-40	85	°C	non permanent
<b>Storage Temperature</b>	-40	85	°C	non permanent

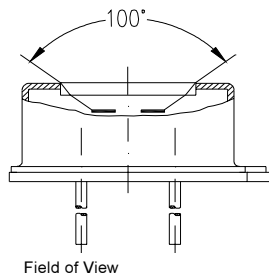
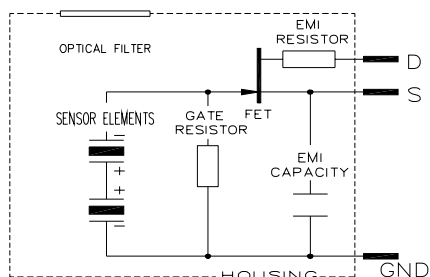

Right for modification reserved / WS / 29.6.2001

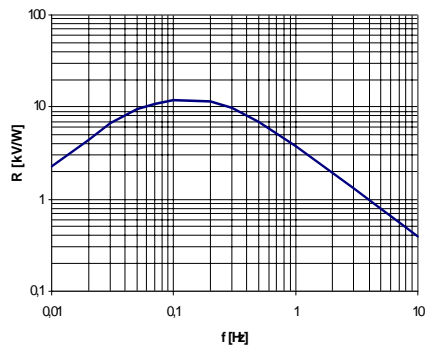

Frequency Response

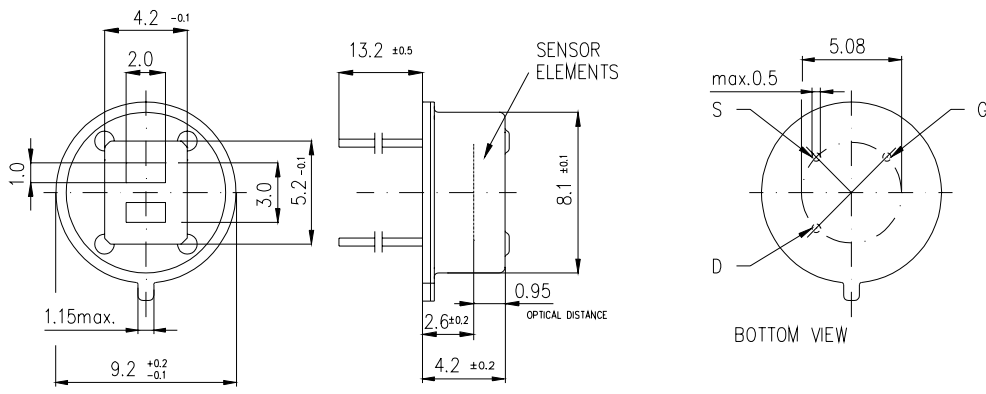

Dimensions in mm

Europe:  
**PerkinElmer** Optoelectronics GmbH  
 Wenzel Jaksch Str 31  
 Wiesbaden / Germany  
 Phone +49(0)611 492 0  
 Fax +49(0)611 492 170

USA:  
**PerkinElmer** Optoelectronics  
 2175 Mission College Blvd  
 Santa Clara, CA 95054  
 Phone +408 565 0830  
 Fax +408 565 0703

Asia:  
**PerkinElmer** Optoelectronics  
 47, Ayer Rajah Crescent #06-12  
 Singapore 139947  
 Phone +65 775 2022  
 Fax +65 775 1008

SUNSTAR 自动化 <http://www.sensor-ic.com/> TEL: 0755-83376489 FAX:0755-83376182 E-MAIL: szss20@163.com

