

# ATS640JSB

Data Sheet  
27627-114

## TRUE ZERO-SPEED, SELF-CALIBRATING, DIFFERENTIAL HALL-EFFECT GEAR-TOOTH SENSOR FOR TWO-WIRE APPLICATIONS

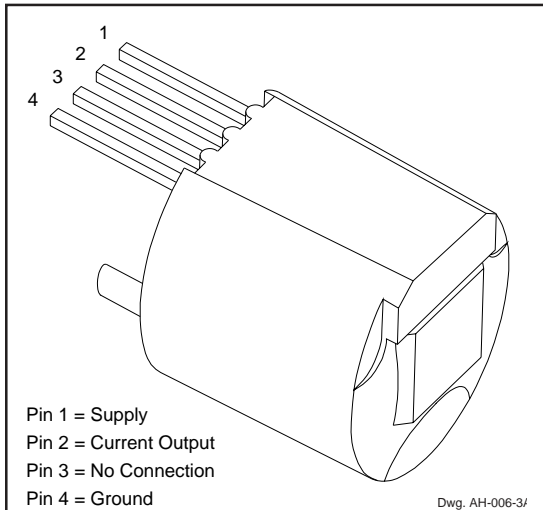

**PRELIMINARY INFORMATION**  
(subject to change without notice)  
August 28, 2002

### ABSOLUTE MAXIMUM RATINGS at $T_A = 25^\circ\text{C}$

Supply Voltage, $V_{CC}$ .....	26.5 V*
Reverse Supply Voltage, $V_{RCC}$ .....	-24 V
Output OFF Voltage, $V_{OUT}$ .....	26.5 V
Reverse Output Current, $I_{ROUT}$ .....	50 mA
Package Power Dissipation, $P_D$ .....	See Graph
Operating Temperature Range, $T_A$ .....	-40°C to +115°C*
Storage Temperature, $T_S$ .....	+170°C

\* Operation at increased supply voltages with external circuitry is described in Applications Information. Devices for operation at increased temperatures are available on special order.

The ATS640JSB Hall-effect gear-tooth sensor is a peak detecting device that uses internal gain control to provide extremely stable duty cycles down to zero speed. Each sensor module consists of a high-temperature plastic shell that holds together a samarium-cobalt magnet, a pole piece, and a true zero-speed BiCMOS differential Hall-effect gear-tooth sensor IC that has been optimized to the magnetic circuit. This small package can be easily assembled and used in conjunction with a wide variety of gear shapes and sizes.

The gear-sensing technology used for this sensor module is Hall-effect based. The sensor incorporates a dual-element Hall IC that switches in response to differential magnetic signals created by a ferrous target. The sophisticated self-calibrating digital-processing circuitry normalizes the internal gain of the device to minimize the effect of air gap variations, and to reduce vibration sensitivity. The circuit eliminates magnet and system offsets such as those caused by tilt yet provides zero-speed detection capabilities without the associated running jitter inherent in classical digital solutions.

This sensor system is ideal for use in gathering speed, position, and timing information using gear-tooth-based configurations. The ATS640JSB is particularly suited to those applications that require extremely accurate duty cycle control or accurate edge detection. The lower vibration sensitivity also makes this device extremely useful for transmission speed sensing.

continued next page...

*Some restrictions may apply to certain types of sales.  
Contact factory for details.*

Always order by complete part number: **ATS640JSB**.

# ATS640JSB TRUE ZERO-SPEED, TWO-WIRE GEAR-TOOTH SENSOR

## FEATURES AND BENEFITS

- Internal Current Regulator for 2-Wire Operation
- True Zero-Speed Operation
- Self Calibrating
- Extremely Stable Duty Cycle with Temperature
- Fully Optimized Differential Digital Gear-Tooth Sensor
- Large Operating Air Gaps
- Air-Gap Independent Switch Points
- High Vibration Immunity
- Single-Chip Sensing IC for High Reliability
- Digital Output Representing Target Profile
- Small Mechanical Size
- Optimized Magnetic Circuit
- <200  $\mu$ s Typical Power-On Time
- AGC and Reference-Adjust Circuit
- Under-Voltage Lockout
- Wide Operating Voltage Range
- Defined Power-On State

## TYPICAL APPLICATION

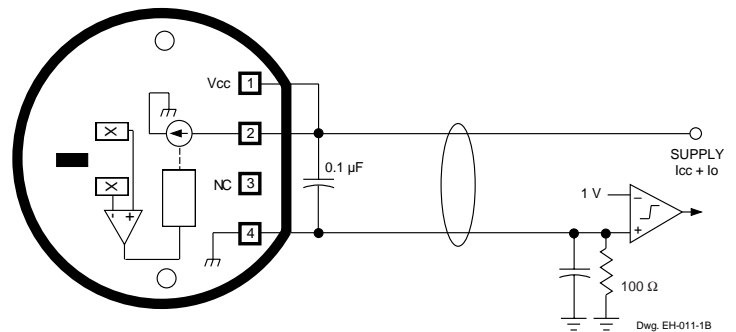

## FUNCTIONAL BLOCK DIAGRAM

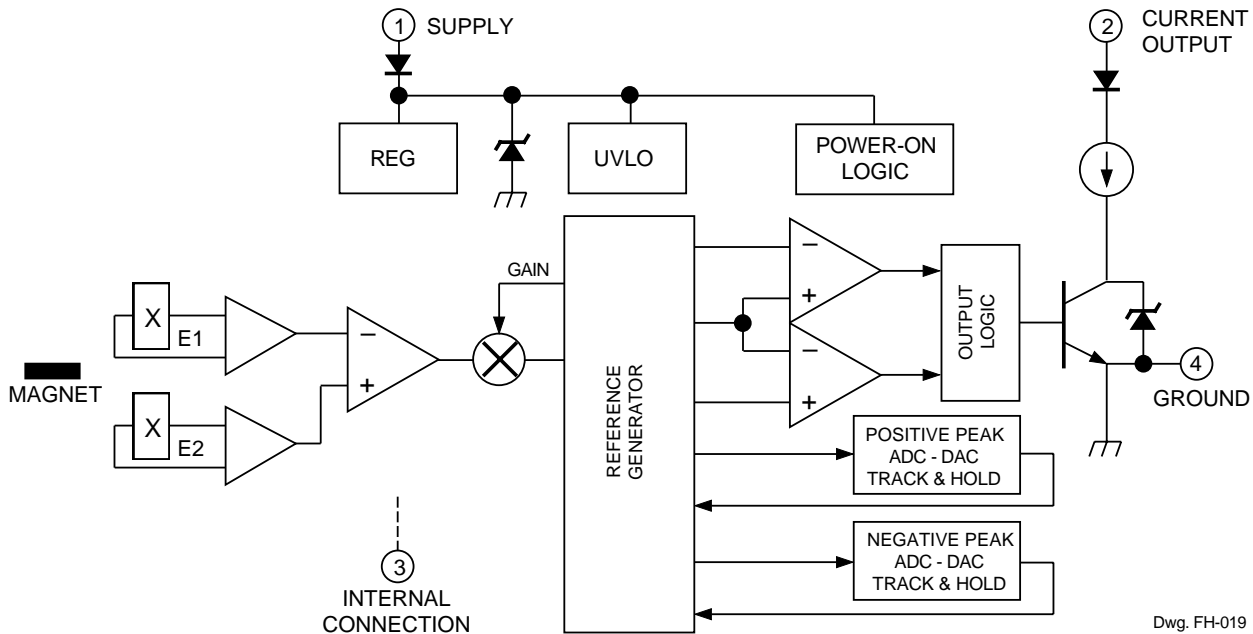

**ATS640JSB**  
**TRUE ZERO-SPEED,**  
**TWO-WIRE**  
**GEAR-TOOTH SENSOR**

**MECHANICAL INFORMATION**

Component	Material	Function	Units
Sensor Face	Thermoset epoxy	Maximum temperature	170°C*
Plastic Housing	Thermoplastic PBT	264 psi deflection temp. (DTUL) 66 psi deflection temp. (DTUL) Approximate melting temperature	204°C 216°C 225°C
Flame Class Rating	—	—	UL94V-0
Leads	Copper	—	—
Lead Finish	90/10 tin/lead solder plate	—	†
Lead Pull	—	—	8 N

\*Temperature excursions to 225 °C for 2 minutes or less are permitted.

†All industry-accepted soldering techniques are permitted for these modules provided the indicated maximum temperature for each component (e.g., sensor face, plastic housing) is not exceeded. Reasonable dwell times, which do not cause melting of the plastic housing, should be used.

**Sensor Location (in millimeters)**

(sensor location relative to package center is the design objective)

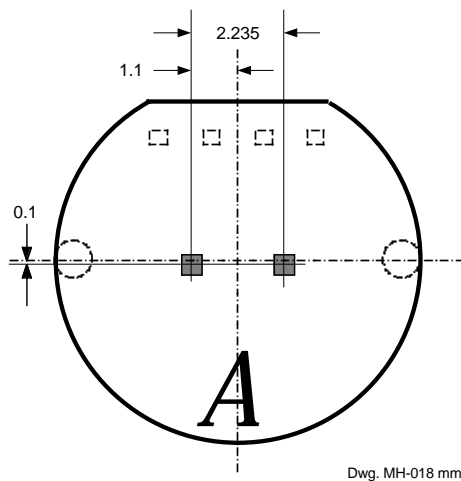

**Lead Cross Section (in millimeters)**

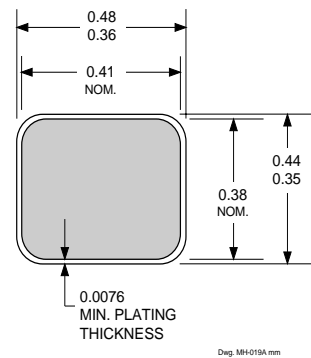

**ATS640JSB**  
**TRUE ZERO-SPEED,**  
**TWO-WIRE**  
**GEAR-TOOTH SENSOR**

**DIMENSIONS IN MILLIMETERS**

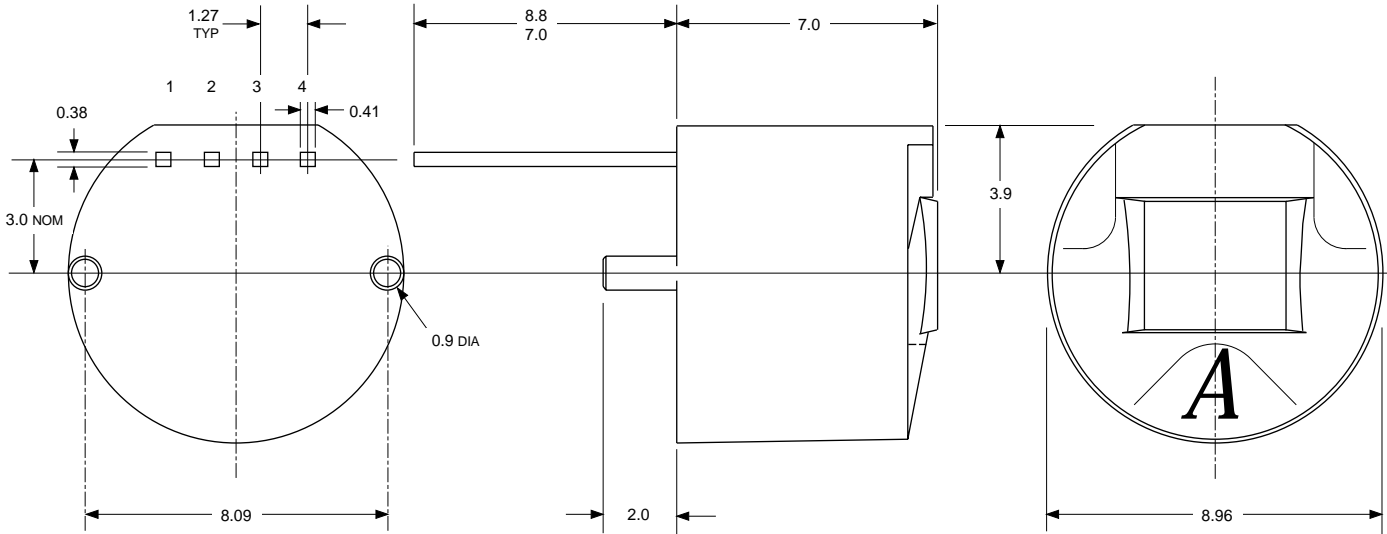

Dwg. MH-017-1B mm

Tolerances, unless otherwise specified: 1 place  $\pm 0.1$  mm, 2 places  $\pm 0.05$  mm.

*The products described herein are manufactured under one or more of the following U.S. patents: 5,045,920; 5,264,783; 5,442,283; 5,389,889; 5,581,179; 5,517,112; 5,619,137; 5,621,319; 5,650,719; 5,686,894; 5,694,038; 5,729,130; 5,917,320; and other patents pending.*

*Allegro MicroSystems, Inc. reserves the right to make, from time to time, such departures from the detail specifications as may be required to permit improvements in the performance, reliability, or manufacturability of its products. Before placing an order, the user is cautioned to verify that the information being relied upon is current.*

*Allegro products are not authorized for use as critical components in life-support appliances, devices, or systems without express written approval.*

*The information included herein is believed to be accurate and reliable. However, Allegro MicroSystems, Inc. assumes no responsibility for its use; nor for any infringements of patents or other rights of third parties that may result from its use.*