

# OKI electronic components

## OPA2048CA

### Self-Scanning Line Sensor

#### GENERAL DESCRIPTION

The OPA2048CA is a 2,048-bit, one-dimensional diode array comprised of PN junction photodetector diodes and CCDs (charge coupled devices). By using a two-phase clock pulse, transfer pulse, and reset pulse, the OPA2048CA can measure incident light.

#### FEATURES

- Dynamic range: TYP 500
- CCD for high sensitivity
- CCD transfer efficiency greater than 99.995%
- Photodetector configured of PN junction photodetector diodes for good blue sensitivity and good output uniformity.
- Photodiodes highly integrated with 13  $\mu\text{m}$  pitch for high resolution
- High-speed scanning
- Low-voltage operation
- Internal output amplifier and compensating amplifier

#### APPLICATIONS

- Facsimiles
- OCRs
- Industrial control
- Monitoring devices
- Object recognition
- Measurement devices

#### PIN CONFIGURATION

##### • Dimensions

(Unit: mm)

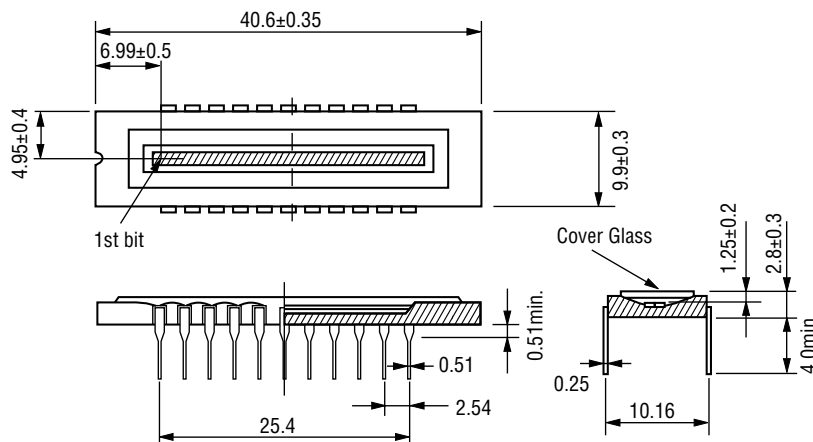

• Pin Connection Block Diagram

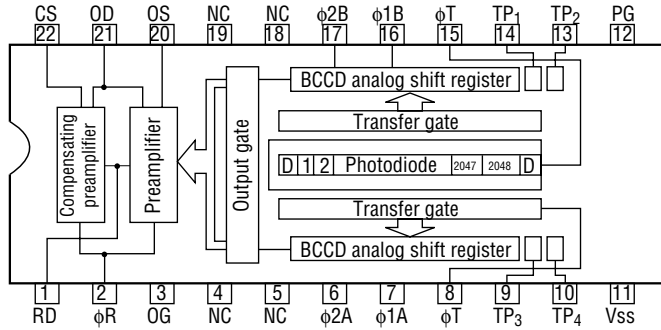

Symbol	Name	Symbol	Name
RD	Reset transistor drain	V <sub>SS</sub>	Substrate bias
φR	Reset transistor gate clock	TP <sub>1</sub>	Test pin (electrical input gate)
OG	Output gate	TP <sub>2</sub>	Test pin (electrical input diode)
φ1A	CCD register clock	TP <sub>3</sub>	Test pin (electrical input gate)
φ1B	CCD register clock	TP <sub>4</sub>	Test pin (electrical input diode)
φ2A	CCD register clock	PG	Photogate
φ2B	CCD register clock	OD	Output transistor drain
φT	Phototransfer gate clock	OS	Output transistor source (video output)
		CS	Compensating transistor source (noise output)

## ABSOLUTE MAXIMUM RATINGS

Parameter	Symbol	Test Condition	Min.	Max.	Unit
Storage Temperature	T <sub>stg</sub>	—	-40	+125	°C
Operating Temperature	T <sub>opr</sub>	—	-20	+85	°C
Clock Voltage	V <sub>φ</sub>	Ta=25°C	-0.3	+18	V
Applied Voltage	V <sub>DD</sub>		-0.3	+18	V

## ELECTRICAL AND OPTICAL CHARACTERISTICS

(Ambient Temperature Ta=25°C)

Parameter		Symbol		Guaranteed Value			Unit
				Min.	Typ.	Max.	
Reset Drain Voltage		V <sub>DD</sub>	V <sub>RD</sub>	11.4	12	12.6	V
Output Transistor Drain Voltage			V <sub>OD</sub>	11.4	12	12.6	V
Output Gate Voltage		V <sub>OG</sub>		4.75	5	5.25	V
Photo Gate Voltage		V <sub>PG</sub>		4.75	5	5.25	V
Substrate Bias		V <sub>SS</sub>		-1.5	-2	-2.5	V
Electrical Input Diode Voltage (TP <sub>2,4</sub> )		V <sub>IS</sub>		11.4	12	12.6	V
Electrical Input Gate Voltage (TP <sub>1,3</sub> )		V <sub>IG</sub>		-0.1	0	0.2	V
Spectral Sensitivity Range		λ <sub>R</sub>		400	—	1000	nm
Reset Clock Pulse Frequency (Video Frequency)		φf <sub>R</sub> (fv)		0.25	1	*1 3	MHz
Clock Pulse Voltage	CCD register	"H"	V <sub>φ<sub>1,2</sub><sup>AB</sup>H</sub>	7	V <sub>DD</sub>	V <sub>DD</sub>	V
		"L"	V <sub>φ<sub>1,2</sub><sup>AB</sup>L</sub>	-0.3	0.4	0.8	V
	Phototransfer	"H"	V <sub>φ<sub>T</sub>H</sub>	7	V <sub>DD</sub>	V <sub>DD</sub>	V
		"L"	V <sub>φ<sub>T</sub>L</sub>	-0.3	0.4	0.8	V
	Reset	"H"	V <sub>φ<sub>R</sub>H</sub>	7	V <sub>DD</sub>	V <sub>DD</sub>	V
		"L"	V <sub>φ<sub>R</sub>L</sub>	-0.3	0.4	0.8	V
Clock Input Capacitance	CCD register	C <sub>φ<sub>1,2</sub><sup>AB</sup></sub>		300	400	520	pF
	Phototransfer	C <sub>φ<sub>T</sub></sub>		10	25	50	pF
	Reset	C <sub>φ<sub>R</sub></sub>		2	4	8	pF
Load Resistance		R <sub>L</sub>		0.9	1	1.5	kΩ
Output DC Level		V <sub>dc</sub>		—	4.0	8.5	V
Power Consumption *2		P <sub>D</sub>		50	70	100	mW

\*1 When load capacitance C<sub>L</sub>=31 pF\*2 When load resistance R<sub>L</sub>=1 kΩ

**POTOELECTRIC CHARACTERISTICS**

(Ambient Temperature Ta=25°C)

Parameter	Symbol	Min.	Typ.	Max.	Unit	Note
Saturation Exposure	Esat	—	0.23	—	lx • sec	*1
Saturation Output Voltage	Vsat	180	250	—	mV	*2
Sensitivity	R <sub>W</sub>	—	1.1	—	V/lx • sec	*1
Output Nonuniformity	U <sub>F</sub>	—	—	±10	%	*3
Dark Output Voltage	Vd	—	0.5	3.1	mV	*4
Dynamic Range	DR	—	500	—	—	*2, *4

Test Conditions  $\left\{ \begin{array}{l} V_{RD}=V_{OD}=V_{\phi}=12\text{ V} \\ V_{PC}=V_{OG}=5\text{ V} \\ V_{SS}=-2\text{ V} \end{array} \right.$  TP2.4=12 V fV=1 MHz  
 TP1.3=0 V TINT=10 ms  
 R<sub>L</sub>=1 kΩ

Conditions

\*1 2856 K tungsten lamp

\*3 Daylight fluorescent lamp 50% saturation exposure

\*2 Daylight fluorescent lamp

\*4 Dark state

**PIXEL CONFIGURATION**

(Ambient Temperature Ta=25°C)

Parameter	Symbol	Central Value	Accuracy	Unit
Arrangement	—	Straight line	—	—
Number of Pixels	—	2048	—	—
Pixel Pitch	P	13	±2.0	μm
Photo Diode Width	D	8	±2.0	μm
Aperture Width	W	13	±2.5	μm
Sensor Length	L	26624	±5.0	μm

\* See "Output Timing" for information concerning dummy pixels.

**Pixel Configuration Diagram**

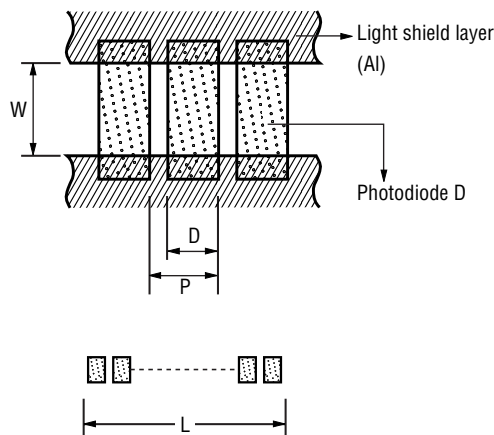

**CLOCK INPUT TIMING CHARACTERISTICS**

(Ambient Temperature Ta=25°C)

	Parameter	Symbol	Min.	Typ.	Max.	Unit	Note
Register	Rise time	$t_{r\phi}$	—	30	100	ns	*1
	Fall time	$t_{f\phi}$	—	20	100	ns	
	Overlap time	$t_{O\phi 1, 2}$	0	20	100	ns	*2
	Blank time	$t_{B\phi 1, 2}$	—	20	100	ns	*3
Phototransfer	Rise time	$t_{r\phi T}$	—	30	100	ns	*4
	Fall time	$t_{f\phi T}$	—	20	100	ns	
	Transfer time duration	$t_{W\phi r}$	5	10	15	$\mu s$	
	Setup time	$t_{S\phi T}$	0	1	10	$\mu s$	
	Hold time	$t_{H\phi T}$	0	1	10	$\mu s$	
Reset	Rise time	$t_{r\phi R}$	—	—	100	ns	*5
	Fall time	$t_{f\phi R}$	—	—	100	ns	
	Duration	$t_{W\phi R}$	80	—	2000	ns	
	Setup time	$t_{S\phi R}$	170	—	2000	ns	
	Hold time	$t_{H\phi R}$	0	—	2000	ns	

**OPA2048CA Input Timing Diagrams**

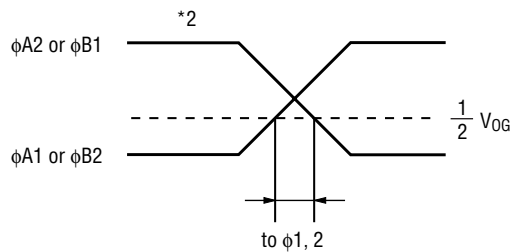
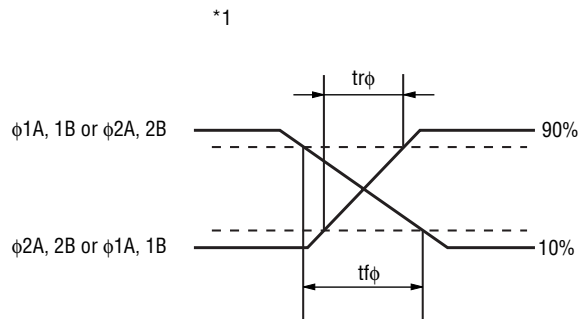

Limited to periods during  $\phi A1$  rise and  $\phi A2$  fall, and  $\phi B2$  rise and  $\phi B1$  fall.

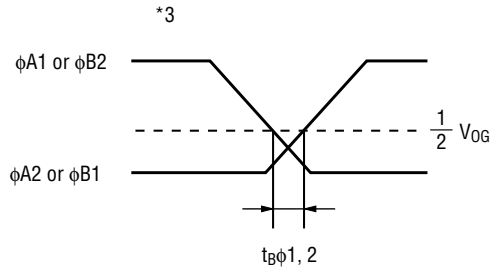

Limited to periods during  $\phi A2$  rise and  $\phi A1$  fall, and  $\phi B1$  rise and  $\phi B2$  fall.

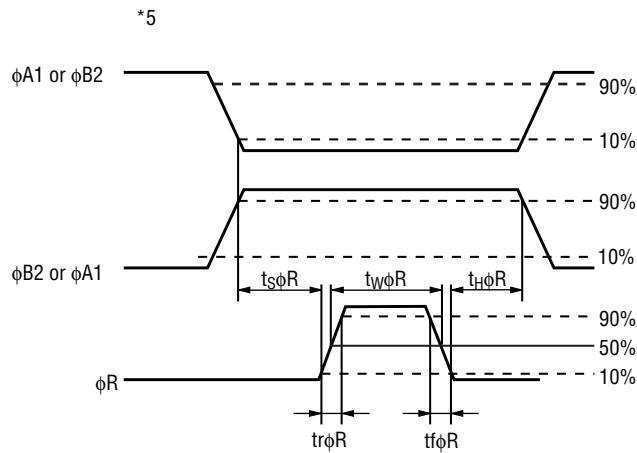
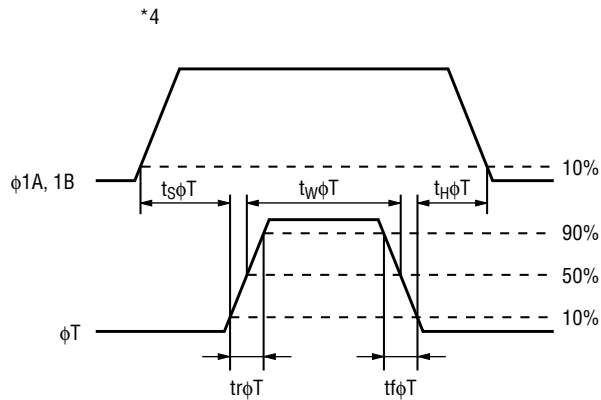

VIDEO OUTPUT TIMING CHARACTERISTICS

(Ambient Temperature Ta=25°C)

Parameter	Symbol	Gvaranteed Values			Unit	Note
		Min.	Typ.	Max.		
Video Rise Delay Time	tdrv	—	55	—	ns	—
Video Rise Time	trv	—	55	—	ns	—
Video Fall Delay Time	tdfv	—	15	—	ns	—
Video Fall Time	tfv	—	30	—	ns	—

Conditions  $\left\{ \begin{array}{l} V_{DD}=V_{RD}=V_{\phi}=12\text{ V} \\ V_{DG}=V_{PG}=5\text{ V} \\ V_{SS}=-2\text{ V} \end{array} \right. \quad \begin{array}{l} R_L=1\text{ k}\Omega \\ C_L=31\text{ pF} \\ T_a=25^\circ\text{C} \end{array} \quad \begin{array}{l} t_{r\phi}=30\text{ ns} \\ t_{r\phi}=35\text{ ns} \\ t_{r\phi R}=15\text{ ns} \end{array}$

Input Timing Chart

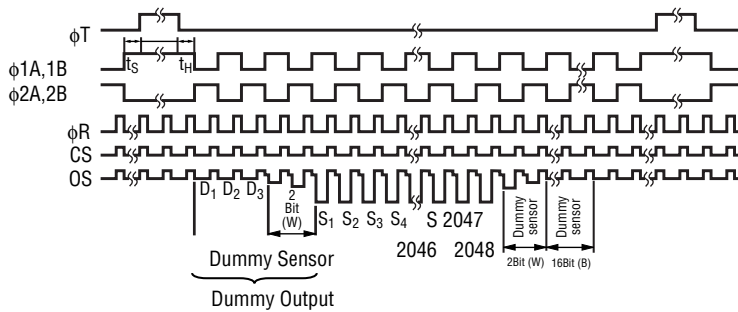

Output Timing Diagrams

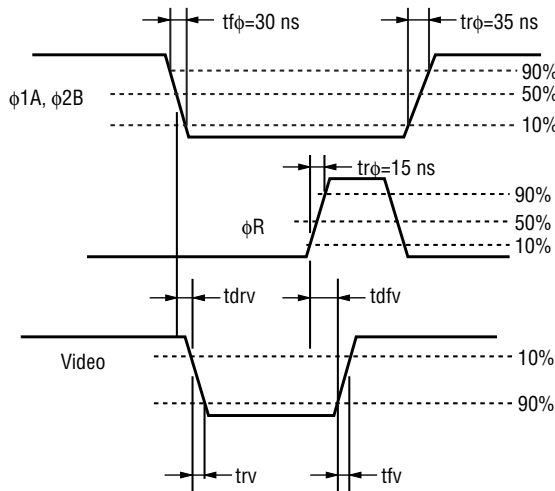

## TYPICAL CHARACTERISTICS

- Photoelectric Conversion Characteristic

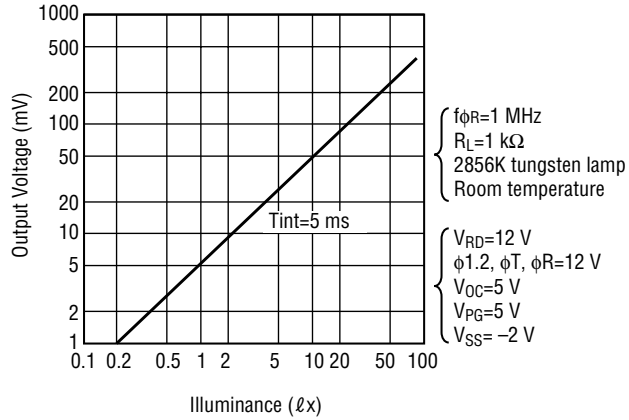

- Dark Output Voltage vs. Temperature Characteristic

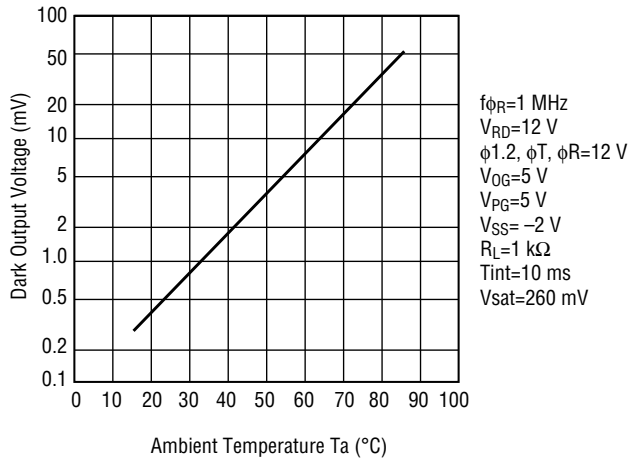



• Spectral Sensitivity Characteristic

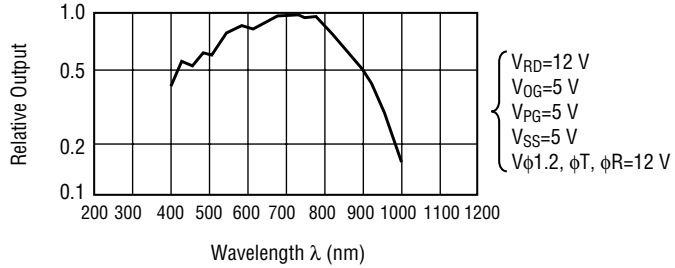

• M.T.F. Characteristics (White Fluorescent Lamp)

