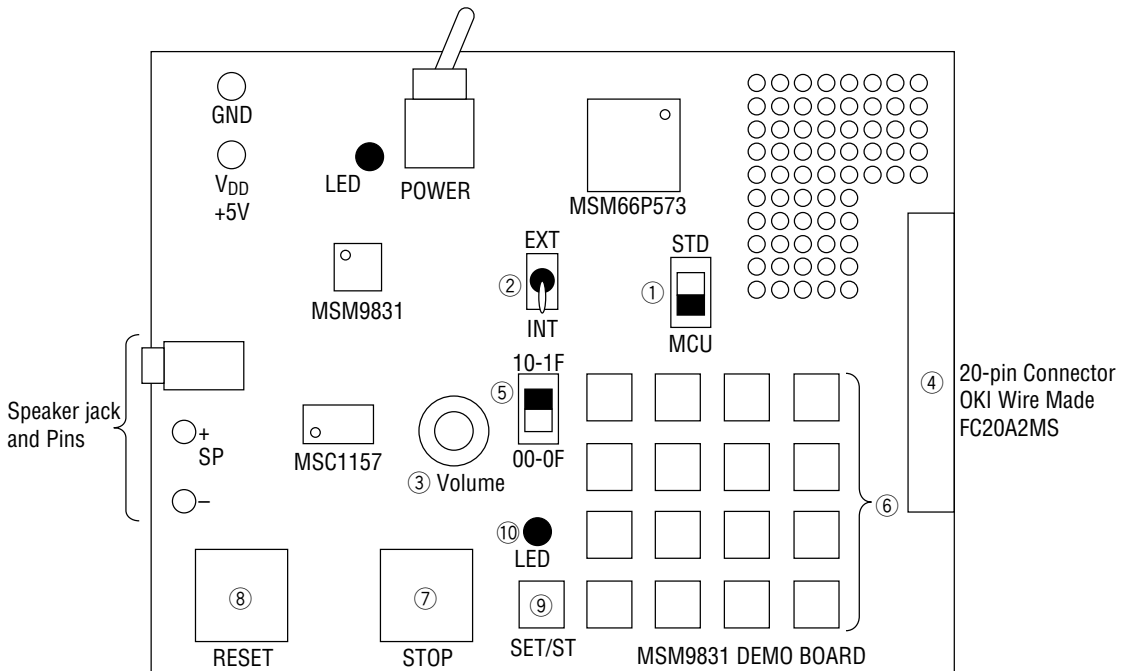

MSM9831 DEMO BOARD**MSM9831 Demonstration Board****GENERAL DESCRIPTION**

The MSM9831 Demonstration Board, controllable by the on-board Micro-Controller Unit, allows you to evaluate/demonstrate sound output from MSM9831 simply by connecting an external speaker to the board. The following two types are available:

Socket Type: Enables you to replace a sample LSI freely for your evaluation convenience.

MSM9831-105 Type: On-board pre-programmed MSM9831-105 containing the following generic phrases:
DTMF (Dial Tones)/Car Winker Sound

BOARD LAYOUT (TOP VIEW)

SETTING UP PARAMETERS

- ① **STD (Stand-alone)/MCU (External MCU) Selector Switch**
To use the board as a stand-alone device controllable by the on-board MCU (MSM66P573), set this switch to the STD side.
To control the board from an external MCU via 20-pin MCU interface, choose MCU.
When the external MCU is selected for controlling the board, functions of switches ⑤~⑨ are disabled.
- ② **INTCK (Internal Clock)/EXTCK (External Clock) Selector Switch**
To use the on-board oscillator (4.096 MHz) as the timing source, set this switch to the INTCK side. If you want to use the external clock signal input (e.g. Clock at other frequency than 4.096 MHz) via 20-pin connector, select EXTCK.
- ③ **Volume Control for the Speaker Amplifier**
Turn left for higher sound level or turn right for lower sound level.
- ④ **20-pin Connector**
When an external MCU is used to control the board, input signals via this 20-pin connector. The following table shows pin-signal assignment for the connector.
Be sure to set the STD/MCU Selector switch to the MCU side, when you control the on-board MSM9831 by signals input this connector. You also need to switch the INTCK/EXTCK Selector to the EXT side if you use the clock signal input via the connector.

Connector Pin No.	Signal	Connector Pin No.	Signal
1	V _{DD}	11	\overline{PI}
2	V _{DD}	12	NC
3	V _{DD}	13	NC
4	XT	14	\overline{PDWN}
5	NC	15	\overline{ST}
6	NC	16	NC
7	NC	17	NC
8	NC	18	GND
9	NC	19	GND
10	NC	20	GND

Note: Leave this connector open when you use the on-board MCU to control the board.

- ⑤ **Address Selector Switch**
MSM9831 has 31 addressable phrases (i.e. 31 phrase addresses: 00001b~11111b). This selector is to set up the MSB (Most Significant Bit), while the lower 4-bit address can be specified by using the Number Keypad ⑥.
To select an address between 01h and 0Fh, set this switch to the "00-0F" side.
To select an address between 10h and 1Fh, set this switch to the "10-1F" side.
- ⑥ **Number Keypad (Phrase Starter)**
By pushing one of 16 keys on the keypad you can start playback of the phrase corresponding to the key you selected. Each 0 to F key corresponds to the lower 4-bit address of phrases respectively.

- ⑦ Stop Switch
Push this switch whenever you want to stop on-going playback.
- ⑧ Reset Switch
Use this switch to reset the on-board MCU.
- ⑨ SET/ST Switch
This switch allows you to use special demonstration features of MSM9831-105.

PLAYING BACK

First, you need to reset the on-board MCU by pushing the Reset switch ⑧ after powering up the board. To start playback of a desired phrase, select the MSB (Most Significant Bit) of the phrase by using the Address Selector switch ⑤, and then specify lower 4-bit phrase address by pushing one of the keys on the Number Keypad ⑥. The board starts to playback the phrase defined by ⑤ and ⑥ in combination.

A later entry supercedes the earlier entry, in other words, if you enter any new phrase address during playback, the board stops playback of the current phrase to start playback the newly entered phrase.

STOPPING PLAYBACK

By pushing the Stop button ⑧ you can stop on-going playback and have the board return to ready status.

SPECIAL FEATURES (DEMONSTRATION FEATURES USED ONLY WITH MSM9831-105)

• DTMF Dial Tone Generator Function

- (1) Switch the Address Selector ⑤ to the 10-1F side.
- (2) Push the SET/ST button ⑨ to enter into Telephone Number Register mode (the LED ⑩ above the switch goes on).
- (3) Enter a telephone number (up to 31 digits) you want to register using the Number Keypad ⑥. The following table shows key-data registered correspondences.

Number Key	Data Registered	Playback on Key Entry
1	1	いち (Japanese)
2	2	に (Japanese)
3	3	さん (Japanese)
4	4	よん (Japanese)
5	5	ご (Japanese)
6	6	ろく (Japanese)
7	7	なな (Japanese)
8	8	はち (Japanese)
9	9	きゅう (Japanese)
A	0	ゼロ (Japanese)
B	*	スター (Japanese)
C	#	シャープ (Japanese)

Note: You can register only one number combination at a time.

- (4) Push the SET/ST button ⑨ again (the LED ⑩ goes off) to start playback of continuous DTMF tones that corresponds to the telephone number registered. Push the Stop button ⑦ to stop playback.

• Car Winker Sound Generator

- (1) Select either one of two types of winker sound by using the Address Selector switch ⑤.
- (2) Push the SET/ST button ⑨ to save your selection (the LED goes on).
- (3) Push the SET/ST button ⑨ again to start playback (the LED goes off) of the selected winker sound. Push the Stop button ⑦ to stop playback.

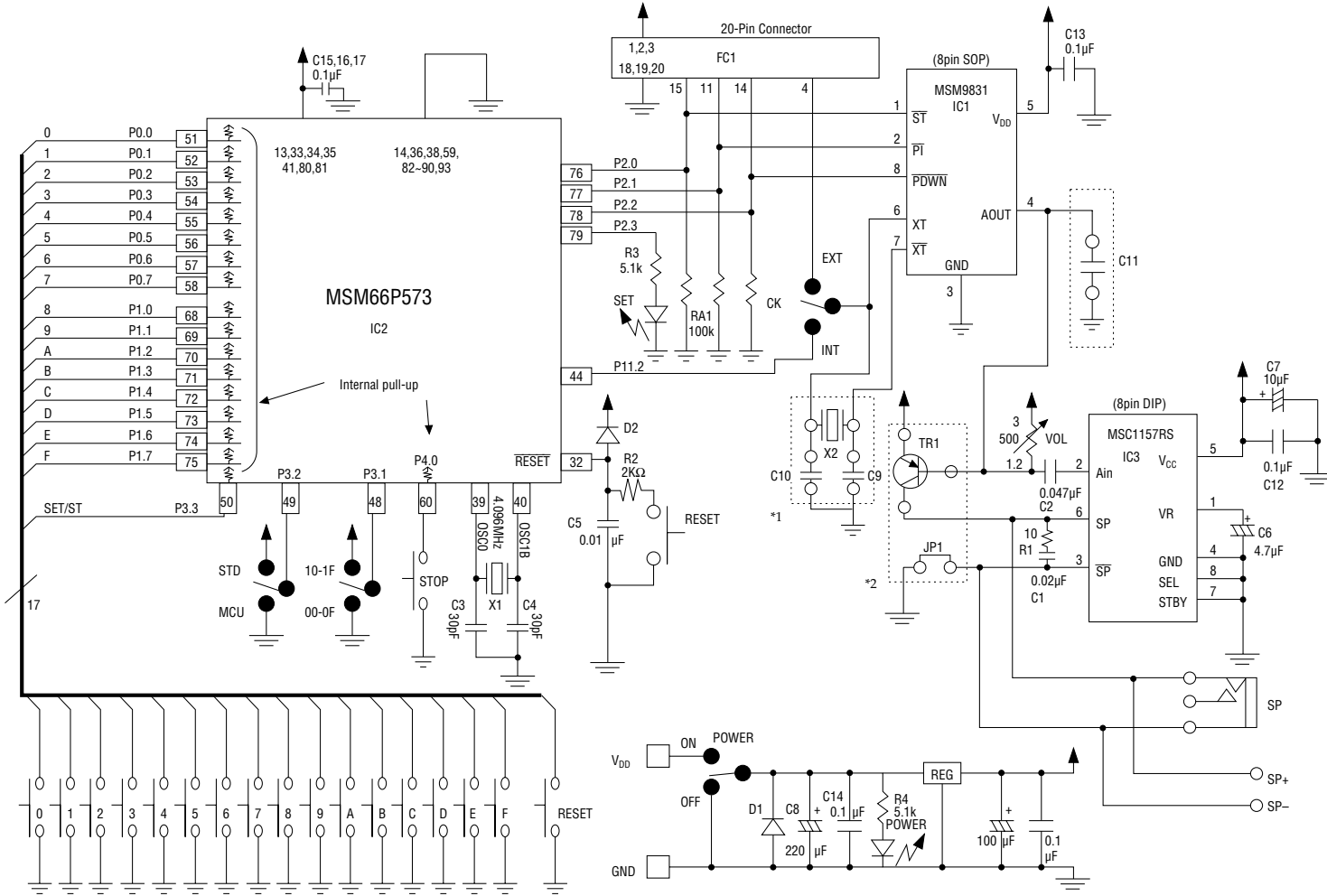

CIRCUIT DIAGRAM

OKI Semiconductor

MSM9831 DEMO BOARD

Circuits within dotted lines are used under different Conditions.

*1. A circuit that uses crystal for driving the MSM9831. Remove the EXT-INT switch when using crystal.

*2. A circuit for transistor-driven speaker use. Remove IC3, VOL, C1, C2, and R1 when using a speaker.

PATTERN LAYOUT

Silk Screen

(Unit: mm)

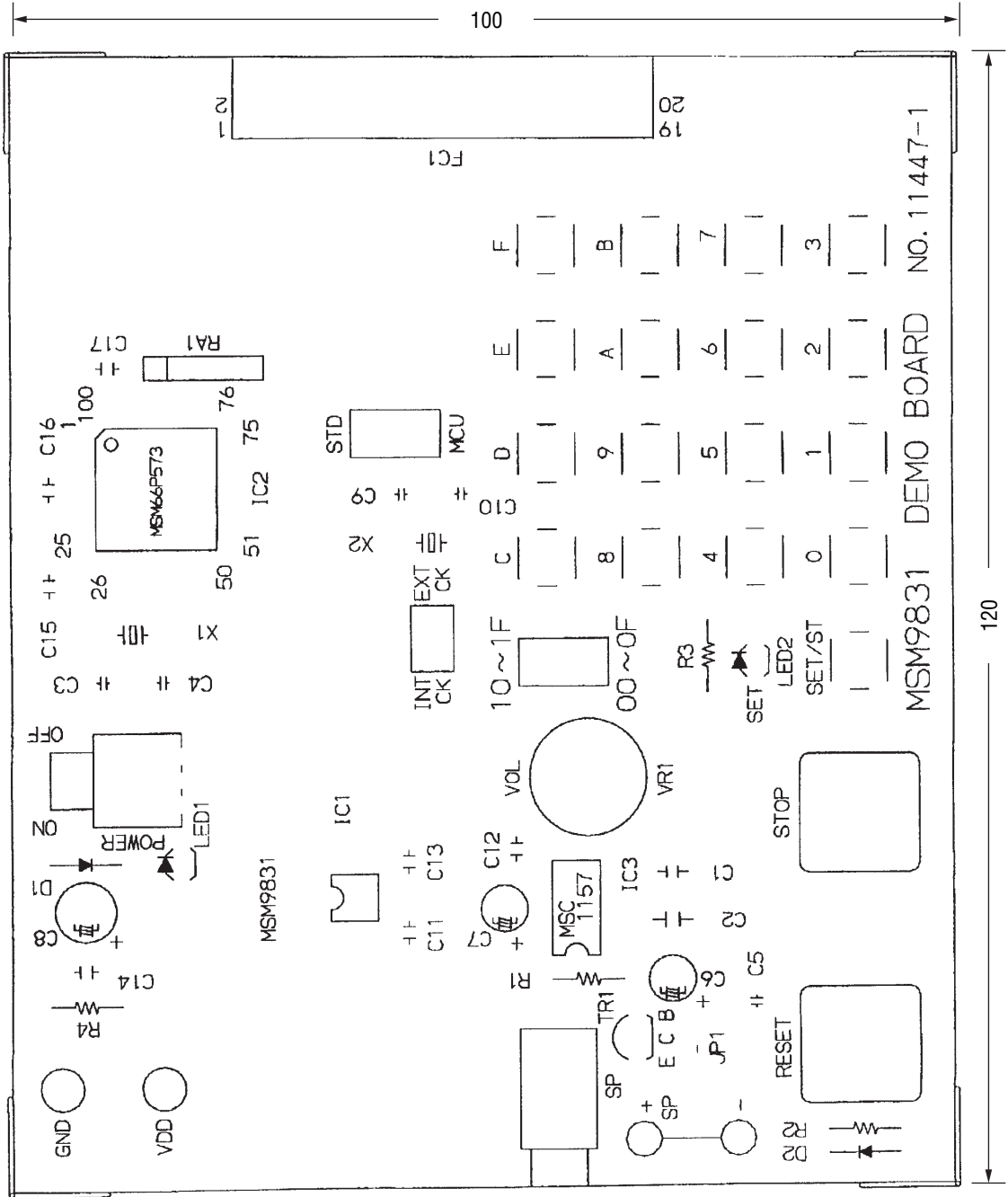

Mounting Side

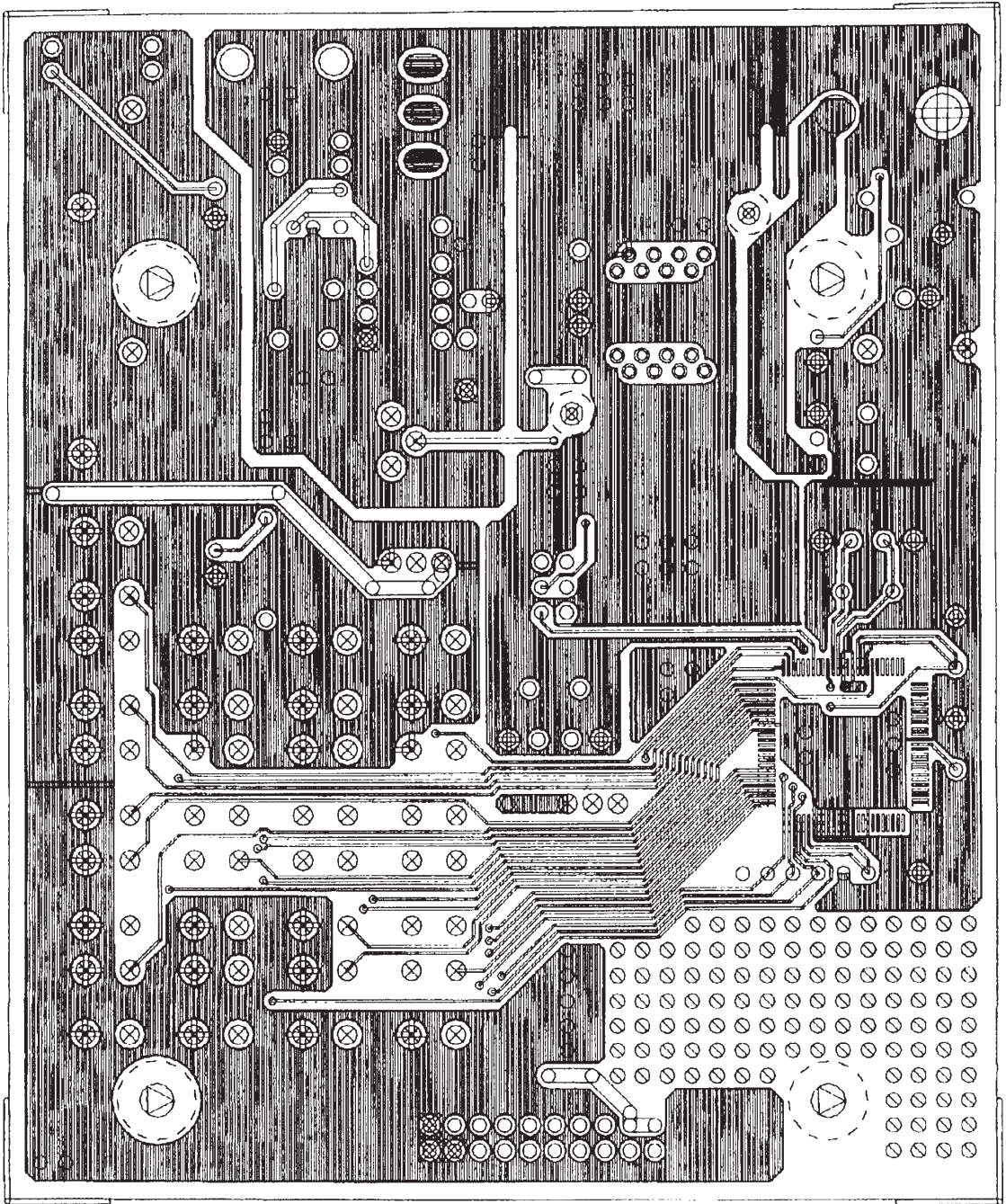

Solder Side

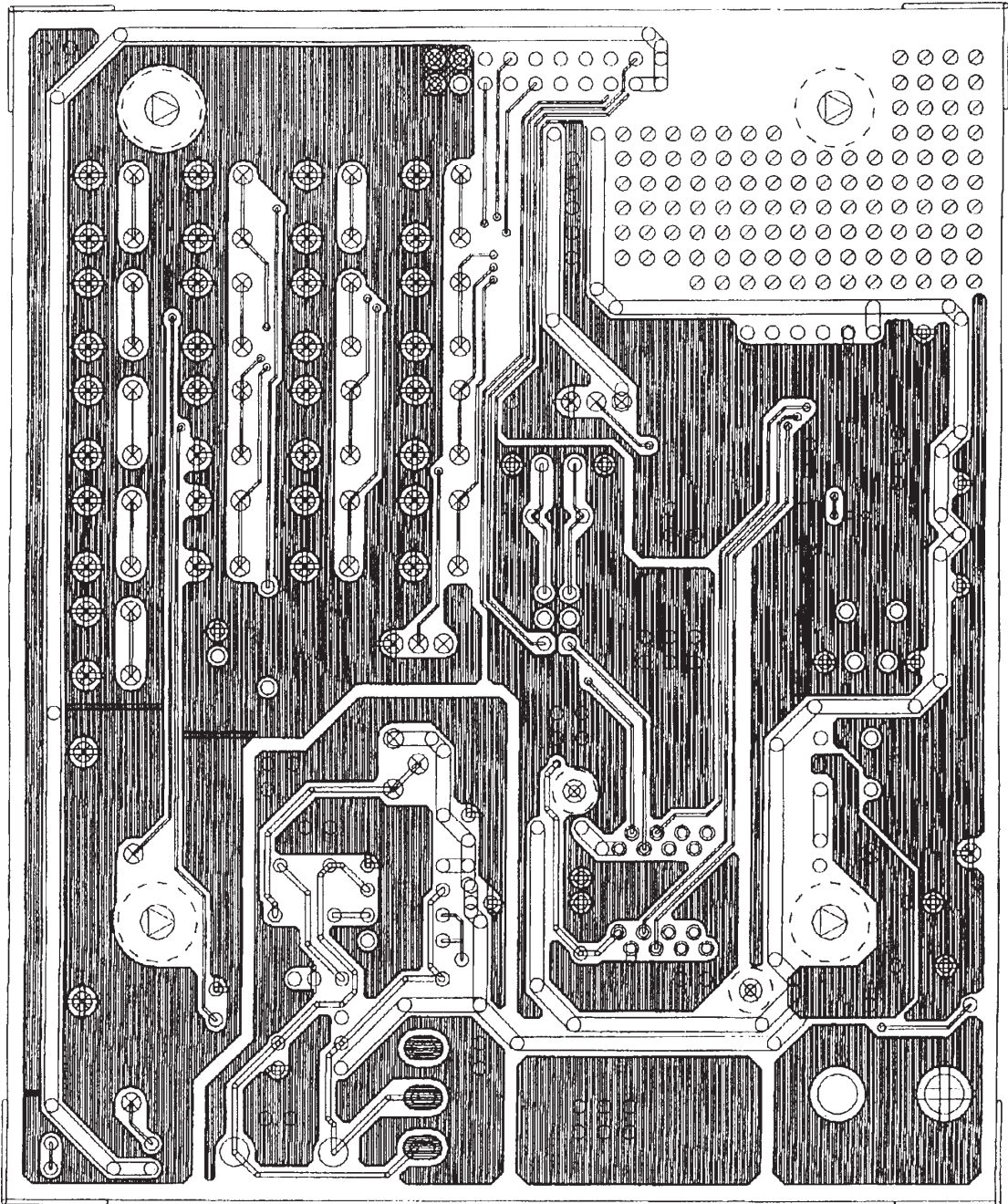

NOTICE

1. The information contained herein can change without notice owing to product and/or technical improvements. Before using the product, please make sure that the information being referred to is up-to-date.
2. The outline of action and examples for application circuits described herein have been chosen as an explanation for the standard action and performance of the product. When planning to use the product, please ensure that the external conditions are reflected in the actual circuit, assembly, and program designs.
3. When designing your product, please use our product below the specified maximum ratings and within the specified operating ranges including, but not limited to, operating voltage, power dissipation, and operating temperature.
4. Oki assumes no responsibility or liability whatsoever for any failure or unusual or unexpected operation resulting from misuse, neglect, improper installation, repair, alteration or accident, improper handling, or unusual physical or electrical stress including, but not limited to, exposure to parameters beyond the specified maximum ratings or operation outside the specified operating range.
5. Neither indemnity against nor license of a third party's industrial and intellectual property right, etc. is granted by us in connection with the use of the product and/or the information and drawings contained herein. No responsibility is assumed by us for any infringement of a third party's right which may result from the use thereof.
6. The products listed in this document are intended for use in general electronics equipment for commercial applications (e.g., office automation, communication equipment, measurement equipment, consumer electronics, etc.). These products are not authorized for use in any system or application that requires special or enhanced quality and reliability characteristics nor in any system or application where the failure of such system or application may result in the loss or damage of property, or death or injury to humans. Such applications include, but are not limited to, traffic and automotive equipment, safety devices, aerospace equipment, nuclear power control, medical equipment, and life-support systems.
7. Certain products in this document may need government approval before they can be exported to particular countries. The purchaser assumes the responsibility of determining the legality of export of these products and will take appropriate and necessary steps at their own expense for these.
8. No part of the contents contained herein may be reprinted or reproduced without our prior permission.
9. MS-DOS is a registered trademark of Microsoft Corporation.

Copyright 1999 Oki Electric Industry Co., Ltd.
