

OKI

INSTRUCTION MANUAL

MSM7582 Evaluation Board

Oki Electric Industry Co., Ltd.

FIRST EDITION

ISSUE DATE: APR., 1995

OKI Semiconductor

MSM7582 Evaluation Board

$\pi/4$ Shift QPSK MODEM

This board is used to evaluate the MSM7582 device ($\pi/4$ shift QPSK modem LSI). The evaluation board is provided with peripherals needed to operate the LSI, having the capability to evaluate its characteristics easily.

For details of specifications and functions of the MSM7582, refer to data sheets.

1. Configuration of Evaluation Board

- Evaluation board 1
- Attached power cord 1
- BNC converting connectors 6

2. Circuit Diagrams of Evaluation Board

- Circuit diagram Fig. 1.1, Fig. 1.2
- Board layout Fig. 2

3. Use and It's Note

Supply power to the evaluation board via the attached power cord. (Red wire is for +5V, Black for GND, and Brown for +3V.) As shown in the circuit diagram, 5V power supply is for peripherals, and 3V power supply is for D.U.T.

(1) Switches

- ☆ Terminals A to H are used to open/close the MSM7582 signals such as PDN0, PDN1, PDN2, SLS1, SLS2, RCW, AFC, and RPR (to corresponding switches). With terminals closed, the signal can be asserted or negated by control switches N to U. With terminals open, control signals can be input directly through pins of the monitor pin[Ⓑ]. For these in puts, HC4050 buffers are provided with that both 3V and 5V drive are capable.
- ☆ Terminals I to K are used to open/close serial control register input for the MSM7582. The MSM7582 mode can be set through closed terminal by peripherals on the board. With terminals open, control signals can be input directly through the pins of monitor pin[Ⓑ] to the serial control register input pins (DEN, EXCK, DIN).
- ☆ Terminal L is used to control input to X1 in the MSM7582. Set this terminal as follows, depending on whether the oscillating circuit of the MSM7582 is used.

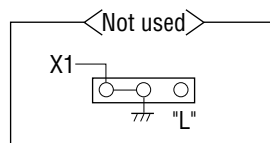
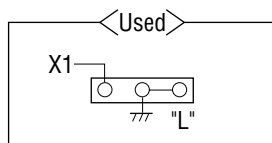

- ☆ Terminal V is used to connect IFCK with X2 or not connect. During use, this terminal must be closed.
- ☆ Terminal R is used to control the input of MCK (Master Clock) to the MSM7582. Set this terminal as follows.

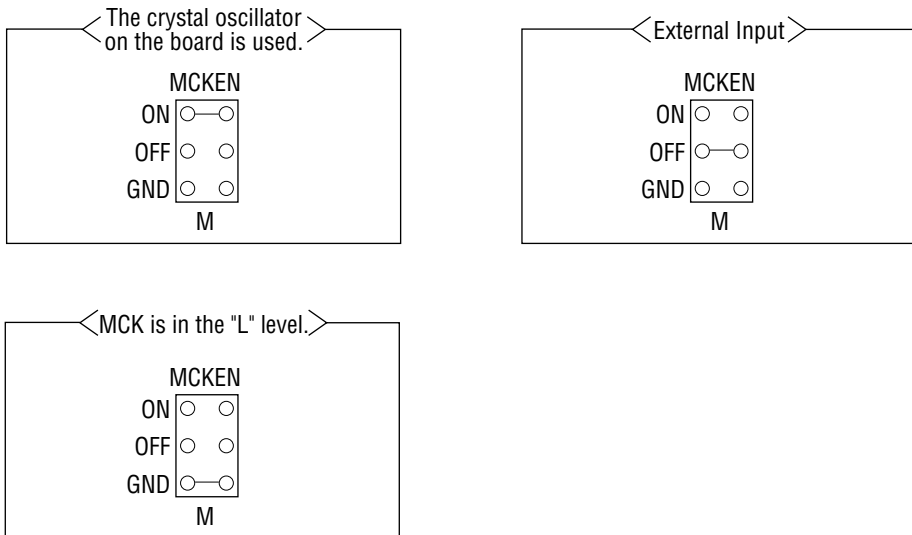

(2) Crystal Oscillator

The MSM7582 uses a crystal oscillator depending on the input IF signal frequency. The following are frequencies used:

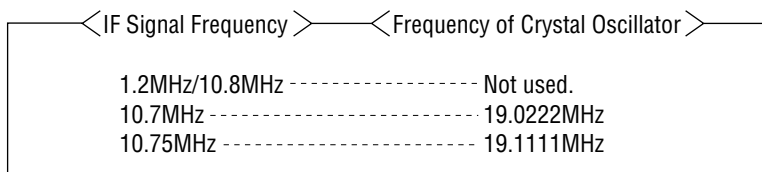

(3) Setting the MSM7582 Serial Control Register

Turning on the CS push button switch allows serial control register of the MSM7582 to be loaded with data set by switches A2 to A0 and B7 to B0.

And each bit corresponds to each SW as follows. If SW is set upwards, the bit is set "1".

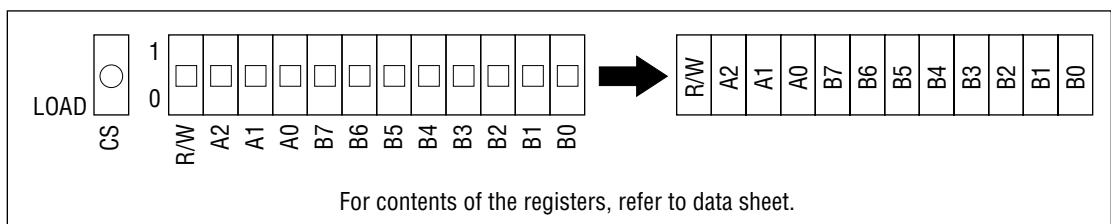

(4) How to Use 32 pin TSOP Socket

Set the IC on the socket with pushing both sides of the socket. The IC is mounted automatically after released. Note that pin "1" is top left hand corner. Handle with care, as 32 pin TSOP has narrow leads that it's easy to bend.

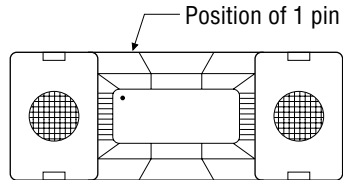

Fig. 1.1 MSM7582 Evaluation Board Circuit Diagram

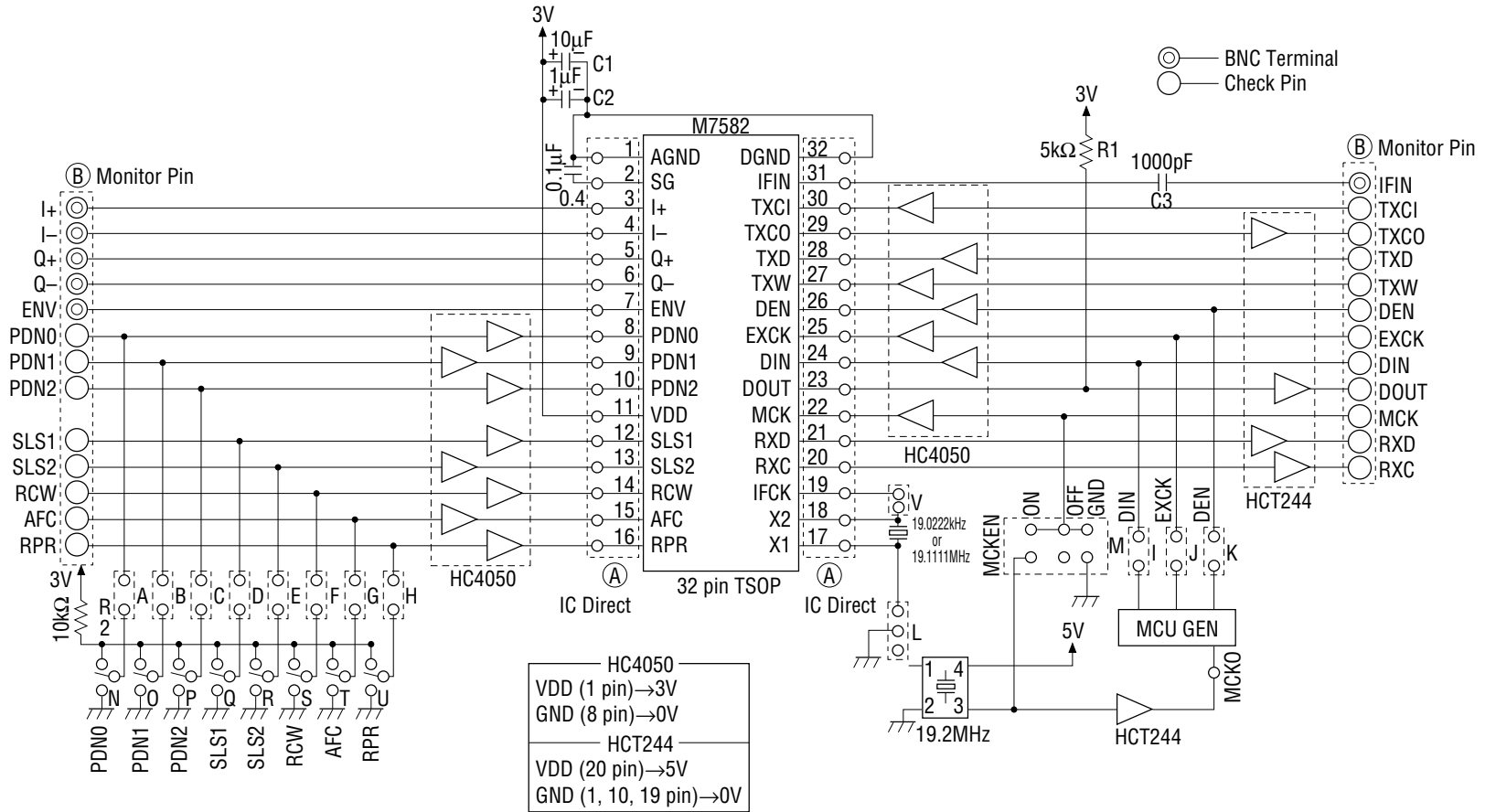

Fig. 1.2 MSM7582 Evaluation Board Circuit Diagram

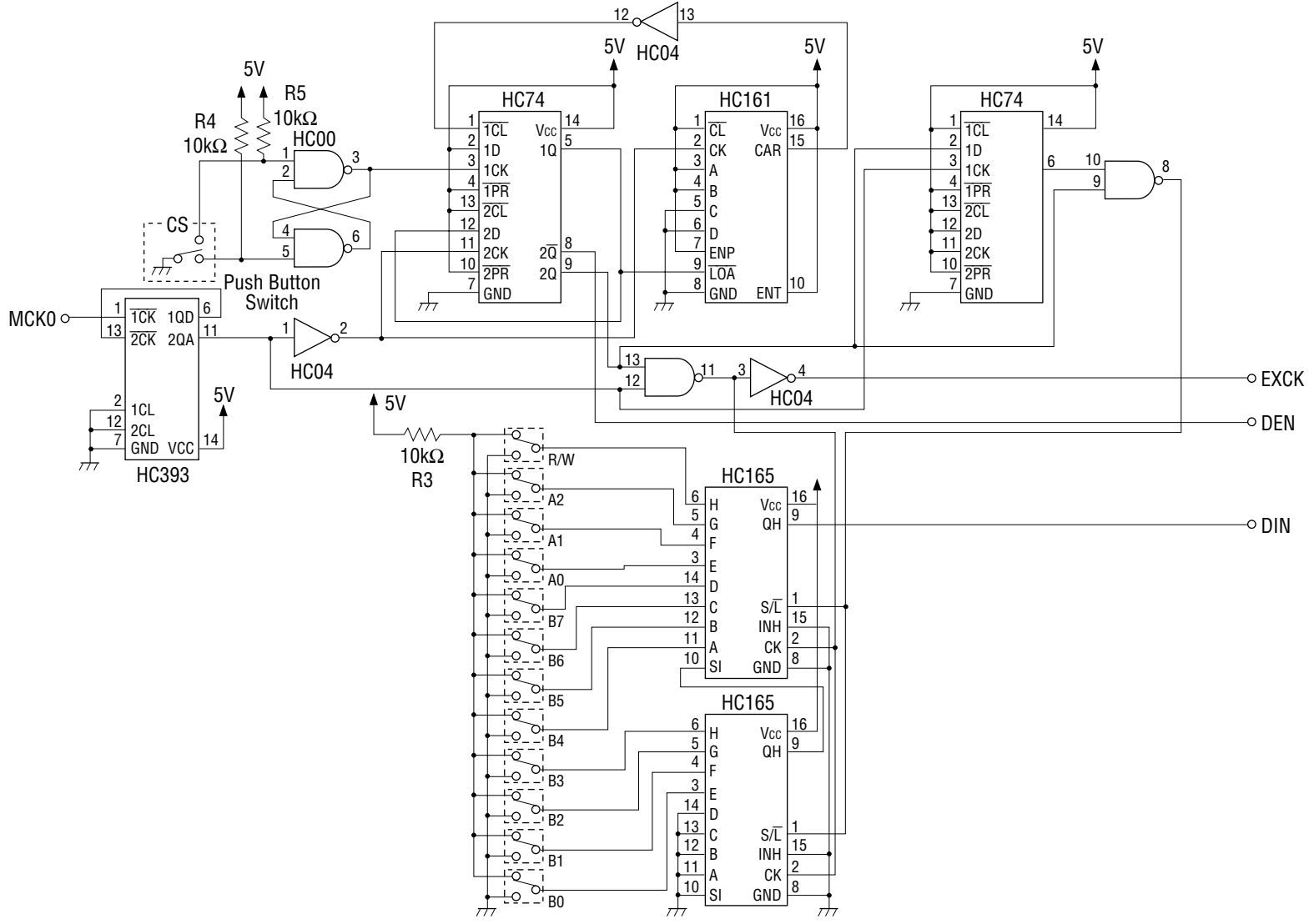

Fig. 2 MSM7582 Evaluation Board Layout

