

# MSM6351/6351L

## Built-in 8 or 5 bit Serial Port and LCD Driver 4-Bit Microcontroller

### GENERAL DESCRIPTION

The MSM6351/6351L is a low-power microcontroller manufactured in silicon gate CMOS technology. Integrated into a single chip are ROM, RAM, five I/O ports, serial I/O port, time-base counter, LCD driver, three interrupts, crystal oscillator, and voltage tripler.

The MSM6351/6351L, which can drive LCD display with higher-count segments, is best suited to battery powered applications, such as watches and game machines.

The built-in 8-bit or 5-bit serial port provides a data communication capability with external machines.

### FEATURES

- Low power consumption
- Large capacity memory
- ROM : 4096 words × 15 bits
- RAM : 1024 words × 4 bits
- I/O port
  - Input-output port : 5 ports × 4 bits (input or output can be specified for each port)
- 62 LCD drivers (1/3 duty or 1/4 duty is selectable. Up to 232 segments can be displayed)
- Single 1.5 V power supply operation (MSM6351)
  - Can be changed to 3.0 V specification by mask option (MSM6351L).
- Melody function
- Built-in watchdog timer
- Built-in 8-bit or 5-bit serial port (asynchronous or synchronous selectable)
- 32.768 kHz crystal oscillator
- Package options:
 

100-pin plastic QFP (QFP100-P-1420-0.65-K)	(Product name :MSM6351-××GS-K/ MSM6351L-××GS-K)
100-pin plastic QFP (QFP100-P-1420-0.65-L)	(Product name :MSM6351-××GS-L/ MSM6351L-××GS-L)
100-pin plastic QFP (QFP100-P-1420-0.65-BK)	(Product name :MSM6351-××GS-BK/ MSM6351L-××GS-BK)
Chip	

×× indicates a code number.

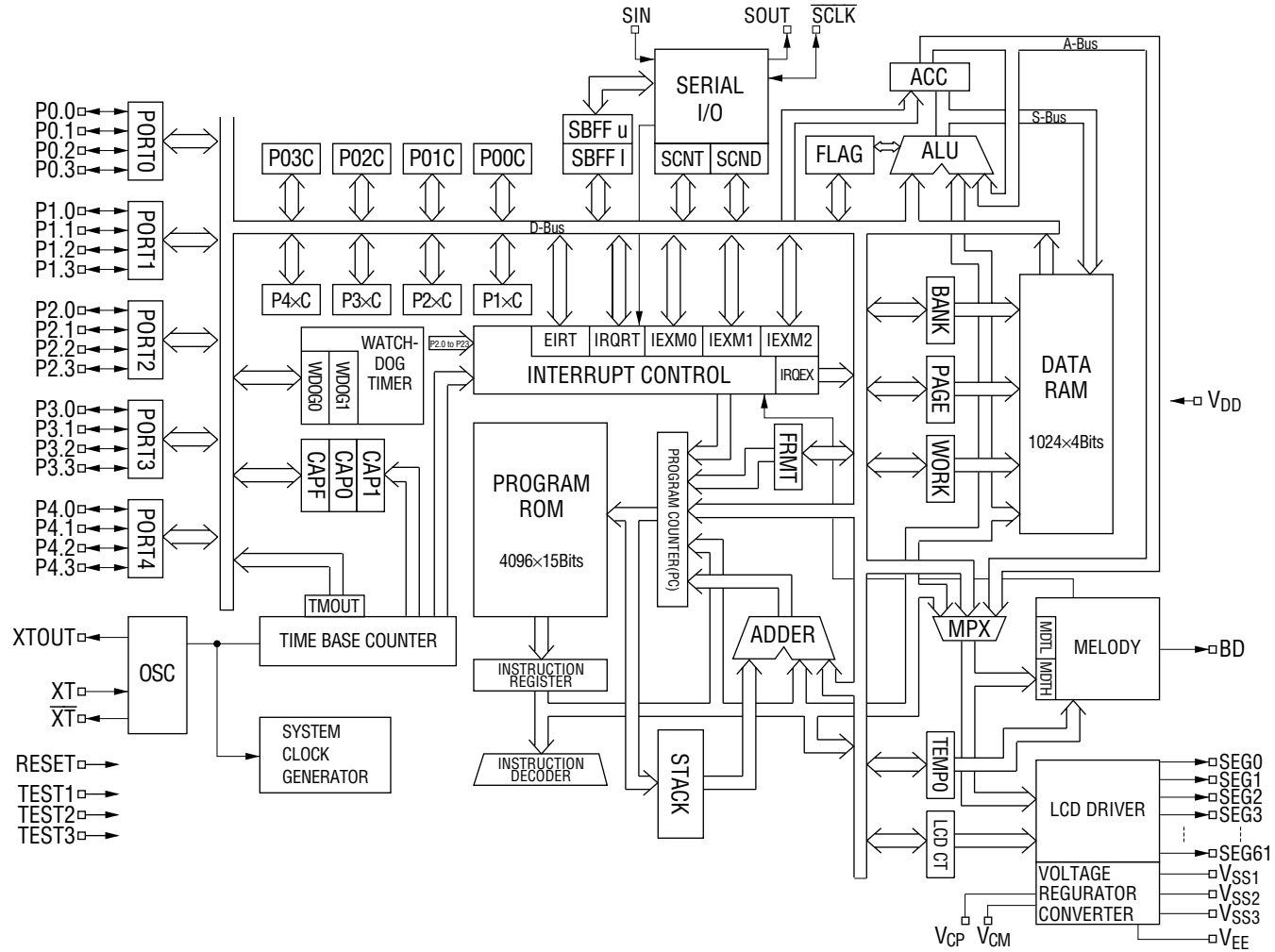

**BLOCK DIAGRAM**

**PIN CONFIGURATION (TOP VIEW)**

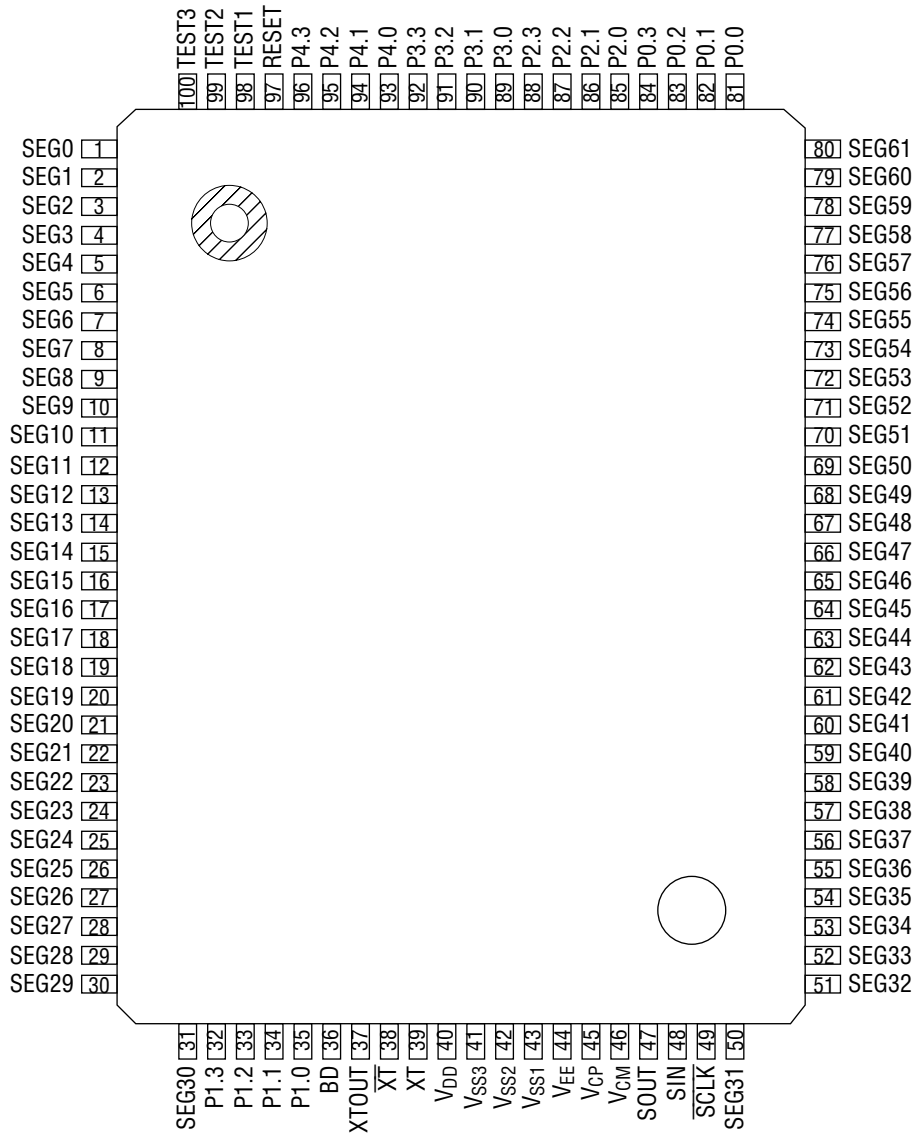

**100-Pin Plastic QFP**

## PIN DESCRIPTIONS

Symbol	Type	Description		I/O Circuitry		
P0.0	I/O	PORT0	• 4-bit I/O port 0	Capture trigger signal	A	
P0.1			The input (*) /output, the existence (*) / absence of pull-down resistance, and the HALT function release enable/disable (*) condition can be selected for each bit.			
P0.2						
P0.3						
P1.0 to P1.3		PORT1		• 4-bit I/O port 1		External interrupt signal
P2.0		PORT2	• 4-bit I/O port 2	The input (*) /output, the existence (*) / absence of pull-down resistance, and the HALT function release enable/disable (*) condition can be selected for each port.		
P2.1						
P2.2						
P2.3						
P3.0 to P3.3		PORT3	• 4-bit I/O port 3			
P4.0 to P4.3		PORT4	• 4-bit I/O port 4			
XTOUT		0	• Oscillator clock output. The oscillator clock is output when XTF (bit 3 of port P00C) is set to "1".			
$\overline{XT}$	0	• Oscillator connection pins.			B	
XT	I					
RESET	I	• Reset input. This is an input with a pull-down resistor. The system is reset when "1" is input.			C	
TEST1	I	• Test input. This is an input with a pull-down resistor.			D	
TEST2						
TEST3						
SIN	I	• Serial port data input.		F		
SOUT	0	• Serial port data output. When the port is not in an output state, this pin is set at high-impedance level, except when HZOUT (bit 3 of port P2XC) =1 and transmitting data.		G		
$\overline{SCLK}$	I/O	• Serial port clock input/output. The input/output (*) is switched by the serial port control register SCNT. In the output mode, the serial clock frequency can be selected from the demultiplied signal (1/1, 1/2 or 1/4 of the system clock).		H		
BD	0	• Melody output (buzzer drive output).		I		
SEG0 to SEG61	0	• LCD drive output with 1/3 bias and 1/3 duty, or 1/3 bias and 1/4 duty. The duty can be switched by LCD control register LCDCNT. A maximum of 177 segments can be displayed when using 1/3 duty and 232 when using 1/4 duty.		—		

\* Means system reset conditions.

**PIN DESCRIPTIONS (continued)**

Symbol	Description	I/O Circuitry
V <sub>DD</sub>	• 0 V power supply pin	—
V <sub>SS1</sub>	• -1.5 V power supply pin (for 1.5 V operation)	—
V <sub>SS2</sub>	• -3.0 V power supply pin (for 3.0 V operation)	—
V <sub>SS3</sub>	• -4.5 V power supply pin	—
V <sub>EE</sub>	• Internal logic power supply pin	—
V <sub>CM</sub>	• Internal voltage converter capacitor connecting pin	—
V <sub>CP</sub>		

**Circuitry on Input/Output Pins**

**A. Input/output port**

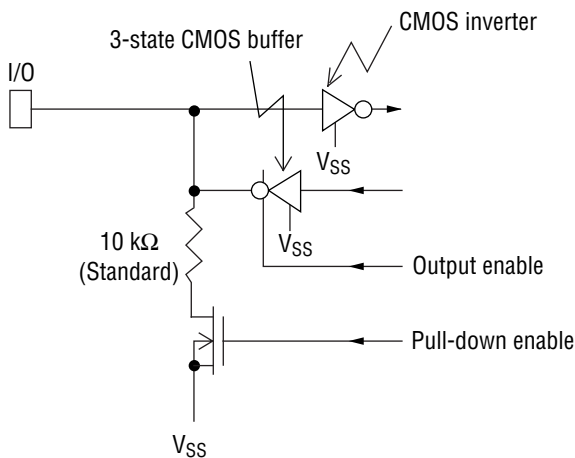

Note:  
 V<sub>SS</sub>: { 1.5 V operation → V<sub>SS1</sub>  
 3.0 V operation → V<sub>SS2</sub>

**B. Oscillator**

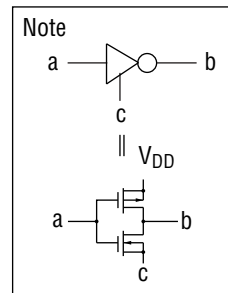
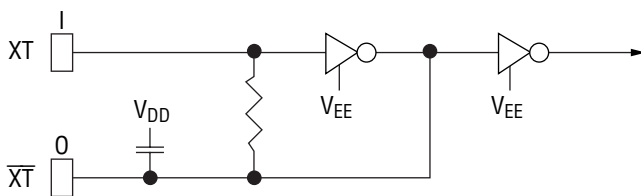

**Circuitry on Input/Output Pins (continued)**

C. RESET input

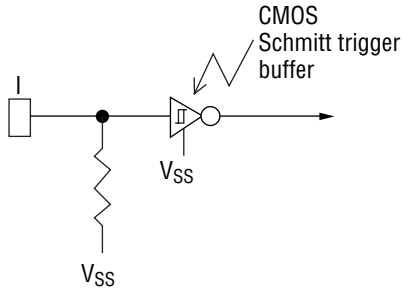

H. SCLK input/output

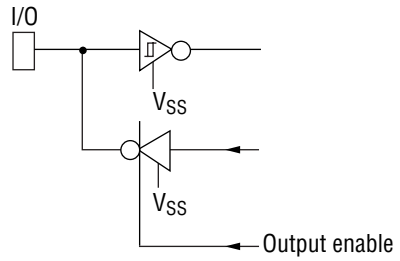

D. TEST input

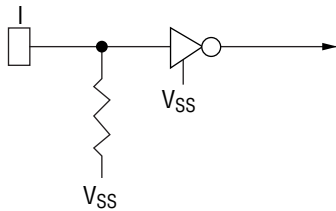

I. BD output

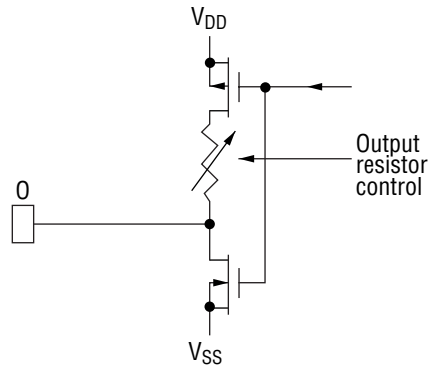

E. XTOUT output

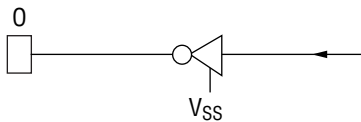

F. SIN input

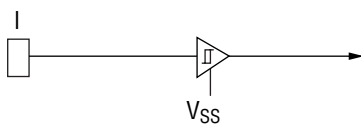

G. SOUT output

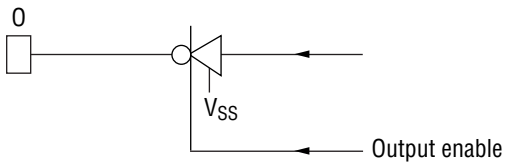

**ABSOLUTE MAXIMUM RATINGS** (MSM6351 (1.5 V Battery), BUF = "0") $V_{DD} = 0\text{ V}$  ( $V_{SS1}$  = Battery Voltage)

Parameter	Symbol	Condition	Rating	Unit
Power Supply Voltage	—	Ta = 25°C	-6.0 to +0.3	V
Input Voltage	V <sub>IN</sub>		V <sub>SS1</sub> - 0.3 to V <sub>SS1</sub> + 0.3	
Output Voltage *1	V <sub>O1</sub>		V <sub>SS1</sub> - 0.3 to V <sub>SS1</sub> + 0.3	
Output Voltage *2	V <sub>O2</sub>		-6.0 to +0.3	
Storage Temperature	T <sub>STG</sub>	—	-55 to +125	°C

\*1 Normal output

\*2 LCD driver output

**RECOMMENDED OPERATING CONDITIONS** (MSM6351 (1.5 V Battery), BUF = "0") $V_{DD} = 0\text{ V}$  ( $V_{SS1}$  = Battery Voltage)

Parameter	Symbol	Condition	Range	Unit
Operating Voltage	V <sub>op</sub>	BUF = "0"	-1.75 to -1.25	V
Operating Temperature	T <sub>op</sub>	—	-20 to +70	°C
Operating Frequency	f <sub>osc</sub>	—	32.768	kHz

**ELECTRICAL CHARACTERISTICS** (MSM6351 (1.5 V Battery), BUF = "0") $V_{DD} = 0\text{ V}$ ,  $V_{SS1} = -1.5\text{ V}$  (Battery Voltage),  $V_{SS2} = -3.0\text{ V}$ ,  $V_{SS3} = -4.5\text{ V}$ ,  $f_{OSC} = 32.768\text{ kHz}$ ,  $C_X = 35\text{ pF}$ ,  $T_a = 25^\circ\text{C}$ 

Parameter	Symbol	Condition	Min.	Typ.	Max.	Unit	Applied Pin
Power Supply Current	$I_{DD}$	*1 *2	—	3.0	—	$\mu\text{A}$	—
Voltage for Oscillation Start	$-V_{OSC}$	Within 2 sec.	—	—	1.4	V	—
Output Current 1 < Common/Segment Output >	$-I_{OH1}$	$V_{OH} = -0.2\text{ V}$	4	—	—	$\mu\text{A}$	SEG0 to SEG61
	$ I_{OMH1} $	$V_{OMH} = V_{SS1} \pm 0.2\text{ V}$	4	—	—		
	$ I_{OML1} $	$V_{OML} = V_{SS2} \pm 0.2\text{ V}$	4	—	—		
	$-I_{OL1}$	$V_{OL} = -4.3\text{ V}$	4	—	—		
Output Current 2	$-I_{OH2}$	$V_O = -0.5\text{ V}$	150	—	—	$\mu\text{A}$	PORT0 to PORT4 *3, SOUT, SCLK, XTOUT
	$I_{OL2}$	$V_O = -1.0\text{ V}$	150	—	—		
Output Current 3	$-I_{OH3}$	$V_O = -0.5\text{ V}$	7	—	—	$\mu\text{A}$	BD
	$I_{OL3}$	$V_O = -1.0\text{ V}$	20	—	—		
Input Current 1	$-I_{IH1}$	$V_I = 0\text{ V}$ I/O input With pull-down resistor	75	150	300	$\mu\text{A}$	PORT0 to PORT4
Input Leakage Current	$ I_{IL2} $	$V_I = 0\text{ V}$ , $-1.5\text{ V}$ I/O input Without pull-down resistor	—	—	1	$\mu\text{A}$	PORT0 to PORT4, SCLK, SIN, SOUT
Input Current 3	$-I_{IH3}$	$V_I = 0\text{ V}$ With pull-down resistor	—	4	—	$\mu\text{A}$	RESET
Input Voltage	$-V_{IH}$	—	—	—	0.3	V	All input pins
	$-V_{IL}$	—	1.2	—	—		

\*1 This value depends on program.

\*2 BUF = "0"

\*3 PORT0 = P0.0 to P0.3, PORT1 = P1.0 to P1.3, PORT2 = P2.0 to P2.3, PORT3 = P3.0 to P3.3,  
PORT4 = P4.0 to P4.3



**ABSOLUTE MAXIMUM RATINGS** (MSM6351L (3.0 V Battery), Halver used (BUF = "0"))  
 $V_{DD} = 0\text{ V}$  ( $V_{SS2} = \text{Battery Voltage}$ )

Parameter	Symbol	Condition	Rating	Unit
Power Supply Voltage	—	$T_a = 25^\circ\text{C}$	-6.0 to +0.3	V
Input Voltage	$V_{IN}$		$V_{SS2} - 0.3$ to $V_{SS2} + 0.3$	
Output Voltage *1	$V_{O1}$		$V_{SS2} - 0.3$ to $V_{SS2} + 0.3$	
Output Voltage *2	$V_{O2}$		-6.0 to +0.3	
Storage Temperature	$T_{STG}$	—	-55 to +125	$^\circ\text{C}$

\*1 Normal output

\*2 LCD driver output

**RECOMMENDED OPERATING CONDITIONS**(MSM6351L (3.0 V Battery), Halver used (BUF = "0"))  
 $V_{DD} = 0\text{ V}$  ( $V_{SS2} = \text{Battery Voltage}$ )

Parameter	Symbol	Condition	Range	Unit
Operating Voltage	$V_{op}$	Halver used (BUF = "0")	-3.5 to -2.6	V
Operating Temperature	$T_{op}$	—	-20 to +70	$^\circ\text{C}$
Operating Frequency	$f_{osc}$	—	32.768	kHz

**ELECTRICAL CHARACTERISTICS** (MSM6351L (3.0 V Battery), Halver used (BUF="0")) $V_{DD} = 0\text{ V}$ ,  $V_{SS1} = -1.5\text{ V}$ ,  $V_{SS2} = -3.0\text{ V}$  (Battery Voltage),  $V_{SS3} = -4.5\text{ V}$ ,  $f_{OSC} = 32.768\text{ kHz}$ ,  $C_X = 35\text{ pF}$ ,  $T_a = 25^\circ\text{C}$ 

Parameter	Symbol	Condition	Min.	Typ.	Max.	Unit	Applied Pin
Power Supply Current	$I_{DD}$	*1 *2	—	1.5	—	$\mu\text{A}$	—
Voltage for Oscillation Start	$-V_{OSC}$	Within 2 sec.	—	—	2.4	V	—
Output Current 1 < Common/Segment Output >	$-I_{OH1}$	$V_{OH} = -0.2\text{ V}$	4	—	—	$\mu\text{A}$	SEG0 to SEG61
	$ I_{OMH1} $	$V_{OMH} = V_{SS1} \pm 0.2\text{ V}$	4	—	—		
	$ I_{OML1} $	$V_{OML} = V_{SS2} \pm 0.2\text{ V}$	4	—	—		
	$-I_{OL1}$	$V_{OL} = -4.3\text{ V}$	4	—	—		
Output Current 2	$-I_{OH2}$	$V_O = -0.5\text{ V}$	500	—	—	$\mu\text{A}$	PORT0 to PORT4 *3, SOUT, SCLK, XTOUT
	$-I_{OL2}$	$V_O = -2.5\text{ V}$	500	—	—		
Output Current 3	$-I_{OH3}$	$V_O = -0.5\text{ V}$	7	—	—	$\mu\text{A}$	BD
	$-I_{OL3}$	$V_O = -2.5\text{ V}$	20	—	—		
Input Current 1	$-I_{IH1}$	$V_I = 0\text{ V}$ I/O input With pull-down resistor	150	300	600	$\mu\text{A}$	PORT0 to PORT4
Input Leakage Current	$ I_{IL2} $	$V_I = 0\text{ V}$ , $-3\text{ V}$ I/O input Without pull-down resistor	—	—	1	$\mu\text{A}$	PORT0 to PORT4, SCLK, SIN, SOUT
Input Current 3	$-I_{IH3}$	$V_I = 0\text{ V}$ With pull-down resistor	—	25	—	$\mu\text{A}$	RESET
Input Voltage	$-V_{IH}$	—	—	—	0.5	V	All input pins
	$-V_{IL}$	—	2.5	—	—		

\*1 This value depends on program.

\*2 When 3 V battery with halver is used (BUF = "0")

\*3 PORT0 = P0.0 to P0.3, PORT1 = P1.0 to P1.3, PORT2 = P2.0 to P2.3, PORT3 = P3.0 to P3.3,  
PORT4 = P4.0 to P4.3

**ABSOLUTE MAXIMUM RATINGS** (MSM6351L (3.0 V Battery), Halver not used (BUF = "1"))  
V<sub>DD</sub> = 0 V (V<sub>SS2</sub> = Battery Voltage)

Parameter	Symbol	Condition	Rating	Unit
Power Supply Voltage	—	Ta = 25°C	-6.0 to +0.3	V
Input Voltage	V <sub>IN</sub>		V <sub>SS2</sub> - 0.3 to +0.3	
Output Voltage *1	V <sub>O1</sub>		V <sub>SS2</sub> - 0.3 to +0.3	
Output Voltage *2	V <sub>O2</sub>		-6.0 to +0.3	
Storage Temperature	T <sub>STG</sub>	—	-55 to +125	°C

\*1 Normal output

\*2 LCD driver output

**RECOMMENDED OPERATING CONDITIONS**

(MSM6351L (3.0 V Battery), Halver not used (BUF = "1"))

V<sub>DD</sub> = 0 V (V<sub>SS2</sub> = Battery Voltage)

Parameter	Symbol	Condition	Range	Unit
Operating Voltage	V <sub>OP</sub>	Halver not used (BUF = "1")	-3.5 to -2.2	V
Operating Temperature	T <sub>OP</sub>	—	-20 to +70	°C
Operating Frequency	f <sub>OSC</sub>	—	32.768	kHz

**ELECTRICAL CHARACTERISTICS** (MSM6351L (3.0 V Battery), Halver not used (BUF="1")) $V_{DD} = 0\text{ V}$ ,  $V_{SS1} = -1.5\text{ V}$ ,  $V_{SS2} = -3.0\text{ V}$  (Battery Voltage),  $V_{SS3} = -4.5\text{ V}$ ,  $f_{OSC} = 32.768\text{ kHz}$ ,  $C_X = 35\text{ pF}$ ,  $T_a = 25^\circ\text{C}$ 

Parameter	Symbol	Condition	Min.	Typ.	Max.	Unit	Applied Pin
Power Supply Current	$I_{DD}$	*1 *2	—	3.0	—	$\mu\text{A}$	—
Voltage for Oscillation Start	$-V_{OSC}$	Within 2 sec.	—	—	2.4	V	—
Output Current 1 Common/Segment Output	$-I_{OH1}$	$V_{OH} = -0.2\text{ V}$	4	—	—	$\mu\text{A}$	SEG0 to SEG61
	$ I_{OMH1} $	$V_{OMH} = V_{SS1} \pm 0.2\text{ V}$	4	—	—		
	$ I_{OML1} $	$V_{OML} = V_{SS2} \pm 0.2\text{ V}$	4	—	—		
	$-I_{OL1}$	$V_{OL} = -4.3\text{ V}$	4	—	—		
Output Current 2	$-I_{OH2}$	$V_O = -0.5\text{ V}$	500	—	—	$\mu\text{A}$	PORT0 to PORT4, *3, SOUT, SCLK, XTOUT
	$-I_{OL2}$	$V_O = -2.5\text{ V}$	500	—	—		
Output Current 3	$-I_{OH3}$	$V_O = -0.5\text{ V}$	7	—	—	$\mu\text{A}$	BD
	$-I_{OL3}$	$V_O = -2.5\text{ V}$	20	—	—		
Input Current 1	$-I_{IH1}$	$V_I = 0\text{ V}$ I/O input With pull-down resistor	150	300	600	$\mu\text{A}$	PORT0 to PORT4
Input Leakage Current	$ I_{IL2} $	$V_I = 0\text{ V}$ , $-3\text{ V}$ I/O input Without pull-down resistor	—	—	1	$\mu\text{A}$	PORT0 to PORT4, SCLK, SIN, SOUT
Input Current 3	$-I_{IH3}$	$V_I = 0\text{ V}$ With pull-down resistor	—	25	—	$\mu\text{A}$	RESET
Input Voltage	$-V_{IH}$	—	—	—	0.5	V	All input pins
	$-V_{IL}$	—	2.5	—	—		

\*1 This value depends on program.

\*2 When halver is not used (BUF = "1")

\*3 PORT0 = P0.0 to P0.3, PORT1 = P1.0 to P1.3, PORT2 = P2.0 to P2.3, PORT3 = P3.0 to P3.3,  
PORT4 = P4.0 to P4.3

INSTRUCTION LIST

	Mnemonic	Instruction code											Description	Machine cycle				
		14	13	12	11	10	9	8	7	6	5	4			3	2	1	0
Arithmetic operation instruction	ADD ACC, REG1	0	0	0	0	0	0	P	0	1	0	0	r <sub>3</sub>	r <sub>2</sub>	r <sub>1</sub>	r <sub>0</sub>	(rP), (ACC), (Z), (C)←(rP) + (ACC)	1
	ADD #i, REG1	0	0	1	1	0	0	P	i <sub>3</sub>	i <sub>2</sub>	i <sub>1</sub>	i <sub>0</sub>	r <sub>3</sub>	r <sub>2</sub>	r <sub>1</sub>	r <sub>0</sub>	(rP), (ACC), (Z), (C)←(rP) + i	1
	ADC REG1	0	0	0	0	0	0	P	0	1	0	1	r <sub>3</sub>	r <sub>2</sub>	r <sub>1</sub>	r <sub>0</sub>	(rP), (ACC), (Z), (C)←decimal adj [(rP) + (ACC) + (C)]	1
	ADCN REG1	0	1	1	0	0	0	P	N <sub>3</sub>	N <sub>2</sub>	N <sub>1</sub>	N <sub>0</sub>	r <sub>3</sub>	r <sub>2</sub>	r <sub>1</sub>	r <sub>0</sub>	(rP), (ACC), (Z), (C)←N adjust [(rP) + (C)]	1
	SUB ACC, REG1	0	0	0	0	0	1	P	0	1	0	0	r <sub>3</sub>	r <sub>2</sub>	r <sub>1</sub>	r <sub>0</sub>	(rP), (ACC), (Z), (C)←(rP) + (ACC)	1
	SUB #i, REG1	0	0	1	1	0	1	P	i <sub>3</sub>	i <sub>2</sub>	i <sub>1</sub>	i <sub>0</sub>	r <sub>3</sub>	r <sub>2</sub>	r <sub>1</sub>	r <sub>0</sub>	(rP), (ACC), (Z), (C)←(rP) - i	1
	SBC REG1	0	0	0	0	0	1	P	0	1	0	1	r <sub>3</sub>	r <sub>2</sub>	r <sub>1</sub>	r <sub>0</sub>	(rP), (ACC), (Z), (C)←decimal adj [(rP) - (ACC) - (C)]	1
	SBCN REG1	0	1	1	0	0	1	P	N <sub>3</sub>	N <sub>2</sub>	N <sub>1</sub>	N <sub>0</sub>	r <sub>3</sub>	r <sub>2</sub>	r <sub>1</sub>	r <sub>0</sub>	(rP), (ACC), (Z), (C)←N adjust [(rP) - (C)]	1
	CMP ACC, REG1	0	0	0	0	0	1	P	1	1	1	0	r <sub>3</sub>	r <sub>2</sub>	r <sub>1</sub>	r <sub>0</sub>	(Z), (C)←(rP) - (ACC)	1
	CMP #i, REG1	0	0	1	0	1	1	P	i <sub>3</sub>	i <sub>2</sub>	i <sub>1</sub>	i <sub>0</sub>	r <sub>3</sub>	r <sub>2</sub>	r <sub>1</sub>	r <sub>0</sub>	(Z), (C)←(rP) - i	1
	INC REG1	0	0	0	0	0	0	P	0	0	0	1	r <sub>3</sub>	r <sub>2</sub>	r <sub>1</sub>	r <sub>0</sub>	(rP), (ACC), (Z), (C)←(rP) + 1	1
	INCD REG2	1	0	0	0	b <sub>1</sub>	b <sub>0</sub>	0	P <sub>3</sub>	P <sub>2</sub>	P <sub>1</sub>	P <sub>0</sub>	r <sub>3</sub>	r <sub>2</sub>	r <sub>1</sub>	r <sub>0</sub>	(rPb), (ACC), (Z), (C)←(rPb) + 1	1
	DEC REG1	0	0	0	0	0	1	P	0	0	0	1	r <sub>3</sub>	r <sub>2</sub>	r <sub>1</sub>	r <sub>0</sub>	(rP), (ACC), (Z), (C)←(rP) - 1	1
DECD REG2	1	0	0	1	b <sub>1</sub>	b <sub>0</sub>	0	P <sub>3</sub>	P <sub>2</sub>	P <sub>1</sub>	P <sub>0</sub>	r <sub>3</sub>	r <sub>2</sub>	r <sub>1</sub>	r <sub>0</sub>	(rPb), (ACC), (Z), (C)←(rPb) - 1	1	
Bit manipulation instruction	BIT ACC, REG1	0	0	0	0	0	0	P	1	1	1	0	r <sub>3</sub>	r <sub>2</sub>	r <sub>1</sub>	r <sub>0</sub>	(Z)←(rP <sub>3</sub> )∧(ACC3)∨(rP <sub>2</sub> )∧(ACC2)∨(rP <sub>1</sub> )∧(ACC1)∨(rP <sub>0</sub> )∧(ACC0)	1
	BIT #i, REG1	0	0	1	0	1	0	P	i <sub>3</sub>	i <sub>2</sub>	i <sub>1</sub>	i <sub>0</sub>	r <sub>3</sub>	r <sub>2</sub>	r <sub>1</sub>	r <sub>0</sub>	(Z)←(rP <sub>3</sub> )∧i <sub>3</sub> ∨(rP <sub>2</sub> )∧i <sub>2</sub> ∨(rP <sub>1</sub> )∧i <sub>1</sub> ∨(rP <sub>0</sub> )∧i <sub>0</sub>	1
	BIS ACC, REG1	0	0	0	0	0	0	P	0	1	1	0	r <sub>3</sub>	r <sub>2</sub>	r <sub>1</sub>	r <sub>0</sub>	(rP), (ACC), (Z)←(rP)∨(ACC)	1
	BIS #i, REG1	0	0	1	0	0	0	P	i <sub>3</sub>	i <sub>2</sub>	i <sub>1</sub>	i <sub>0</sub>	r <sub>3</sub>	r <sub>2</sub>	r <sub>1</sub>	r <sub>0</sub>	(rP), (ACC), (Z)←(rP)∨i	1
	BIC ACC, REG1	0	0	0	0	0	1	P	0	1	1	0	r <sub>3</sub>	r <sub>2</sub>	r <sub>1</sub>	r <sub>0</sub>	(rP), (ACC), (Z)←(rP)∧(ACC)	1
	BIC #i, REG1	0	0	1	0	0	1	P	i <sub>3</sub>	i <sub>2</sub>	i <sub>1</sub>	i <sub>0</sub>	r <sub>3</sub>	r <sub>2</sub>	r <sub>1</sub>	r <sub>0</sub>	(rP), (ACC), (Z)←(rP)∧i	1
	XOR ACC, REG1	0	0	0	0	0	0	P	0	1	1	1	r <sub>3</sub>	r <sub>2</sub>	r <sub>1</sub>	r <sub>0</sub>	(rP), (ACC), (Z)←(rP)⊕(ACC)	1
XOR #i, REG1	0	0	1	1	1	1	P	i <sub>3</sub>	i <sub>2</sub>	i <sub>1</sub>	i <sub>0</sub>	r <sub>3</sub>	r <sub>2</sub>	r <sub>1</sub>	r <sub>0</sub>	(rP), (ACC), (Z)←(rP)⊕i	1	
Rotate instruction	ROR REG1	0	0	0	0	0	0	P	0	0	1	0	r <sub>3</sub>	r <sub>2</sub>	r <sub>1</sub>	r <sub>0</sub>	(Z), (ACC)←[→(C)→(rP)→]	1
	ROL REG1	0	0	0	0	0	1	P	0	0	1	0	r <sub>3</sub>	r <sub>2</sub>	r <sub>1</sub>	r <sub>0</sub>	(Z), (ACC)←[←(C)←(rP)←]	1
	ASR REG1	0	0	0	0	0	0	P	0	0	1	1	r <sub>3</sub>	r <sub>2</sub>	r <sub>1</sub>	r <sub>0</sub>	(Z), (ACC)←[0→(rP)→(C)]	1
	ASL REG1	0	0	0	0	0	1	P	0	0	1	1	r <sub>3</sub>	r <sub>2</sub>	r <sub>1</sub>	r <sub>0</sub>	(Z), (ACC)←[(C)←(rP)←0]	1
Flag operation instruction	CLG	0	0	0	0	0	0	0	1	0	0	0	0	0	0	0	(G)←0	1
	CLC	0	0	0	0	0	0	0	1	0	0	1	0	0	0	0	(C)←0	1
	CLZ	0	0	0	0	0	0	0	1	0	1	0	0	0	0	0	(Z)←0	1
	CLA	0	0	0	0	0	0	0	1	0	1	1	0	0	0	0	(Z), (C), (G)←0	1
	SEG	0	0	0	0	0	1	0	1	0	0	0	0	0	0	0	(G)←1	1
	SEC	0	0	0	0	0	1	0	1	0	0	1	0	0	0	0	(C)←1	1
	SEZ	0	0	0	0	0	1	0	1	0	1	0	0	0	0	0	(Z)←1	1
	SEA	0	0	0	0	0	1	0	1	0	1	1	0	0	0	0	(Z), (C), (G)←1	1

**INSTRUCTION LIST (continued)**

	Mnemonic	Instruction code														Description	Machine cycle		
		14	13	12	11	10	9	8	7	6	5	4	3	2	1			0	
Data transfer instruction	MOV ACC, REG1	0	0	0	0	0	0	P	1	1	1	1	r <sub>3</sub>	r <sub>2</sub>	r <sub>1</sub>	r <sub>0</sub>	(rP)←(ACC)	When P=0 in bit 8, N=n+1; when P=1, N=-n.	1
	MOVD ACC, REG2	1	0	1	0	b <sub>1</sub>	b <sub>0</sub>	0	P <sub>3</sub>	P <sub>2</sub>	P <sub>1</sub>	P <sub>0</sub>	r <sub>3</sub>	r <sub>2</sub>	r <sub>1</sub>	r <sub>0</sub>	(rPb)←(ACC)		1
	MOV #i, REG1	0	0	1	1	1	0	P	i <sub>3</sub>	i <sub>2</sub>	i <sub>1</sub>	i <sub>0</sub>	r <sub>3</sub>	r <sub>2</sub>	r <sub>1</sub>	r <sub>0</sub>	(rP), (ACC), (Z)←i		1
	MOV REG1, ACC	0	0	0	0	0	1	P	1	1	1	1	r <sub>3</sub>	r <sub>2</sub>	r <sub>1</sub>	r <sub>0</sub>	(ACC), (Z)←(rP)		1
	MOVD REG2, ACC	1	0	1	1	b <sub>1</sub>	b <sub>0</sub>	0	P <sub>3</sub>	P <sub>2</sub>	P <sub>1</sub>	P <sub>0</sub>	r <sub>3</sub>	r <sub>2</sub>	r <sub>1</sub>	r <sub>0</sub>	(ACC), (Z)←(rPb)		1
	EXG REG1	0	0	0	0	0	1	P	0	0	0	0	r <sub>3</sub>	r <sub>2</sub>	r <sub>1</sub>	r <sub>0</sub>	(rP)↔(ACC)		1
	EXGD REG2	0	1	1	1	b <sub>1</sub>	b <sub>0</sub>	0	P <sub>3</sub>	P <sub>2</sub>	P <sub>1</sub>	P <sub>0</sub>	r <sub>3</sub>	r <sub>2</sub>	r <sub>1</sub>	r <sub>0</sub>	(rPb)↔(ACC)		1
Subroutine instruction	CALL adrs	1	1	1	a <sub>11</sub>	a <sub>10</sub>	a <sub>9</sub>	a <sub>8</sub>	a <sub>7</sub>	a <sub>6</sub>	a <sub>5</sub>	a <sub>4</sub>	a <sub>3</sub>	a <sub>2</sub>	a <sub>1</sub>	a <sub>0</sub>	(STACK)←(PC), (PC)←a <sub>11</sub> to a <sub>0</sub> , (SP)←(SP)+1	1	
	RET	0	0	0	0	0	0	0	1	1	0	0	0	0	0	0	(PC)←(STACK)+1, (SP)←(SP)-1	1	
	RTI	0	0	0	0	0	1	0	1	1	0	0	0	0	0	0	(PC)←(STACK)+1, (SP)←(SP)-1 (at INT routine)	1	
Jump instruction	JMP adrs	1	1	0	a <sub>11</sub>	a <sub>10</sub>	a <sub>9</sub>	a <sub>8</sub>	a <sub>7</sub>	a <sub>6</sub>	a <sub>5</sub>	a <sub>4</sub>	a <sub>3</sub>	a <sub>2</sub>	a <sub>1</sub>	a <sub>0</sub>	(PC)←a <sub>11</sub> to a <sub>0</sub>	1	
	AMP @ REG1	0	0	0	0	0	0	0	1	1	0	1	r <sub>3</sub>	r <sub>2</sub>	r <sub>1</sub>	r <sub>0</sub>	(PC)←(PC)+(rP)+1	1	
	JMPO @ REG1	0	0	0	0	0	1	0	1	1	0	1	r <sub>3</sub>	r <sub>2</sub>	r <sub>1</sub>	r <sub>0</sub>	(PC)←(PC)+7Λ(rP)+1	1	
	BGT n	0	0	0	0	1	1	P	0	0	1	n <sub>4</sub>	n <sub>3</sub>	n <sub>2</sub>	n <sub>1</sub>	n <sub>0</sub>	if (G)=1 then (PC)←(PC)+N else (PC)←(PC)+1	1	
	BLE n	0	0	0	0	1	1	P	1	0	1	n <sub>4</sub>	n <sub>3</sub>	n <sub>2</sub>	n <sub>1</sub>	n <sub>0</sub>	if (G)=0 then (PC)←(PC)+N else (PC)←(PC)+1	1	
	BCS n	0	0	0	0	1	1	P	0	0	0	n <sub>4</sub>	n <sub>3</sub>	n <sub>2</sub>	n <sub>1</sub>	n <sub>0</sub>	if (C)=1 then (PC)←(PC)+N else (PC)←(PC)+1	1	
	BCC n	0	0	0	0	1	1	P	1	0	0	n <sub>4</sub>	n <sub>3</sub>	n <sub>2</sub>	n <sub>1</sub>	n <sub>0</sub>	if (C)=0 then (PC)←(PC)+N else (PC)←(PC)+1	1	
	BEQ n (BZE n)	0	0	0	0	1	1	P	0	1	0	n <sub>4</sub>	n <sub>3</sub>	n <sub>2</sub>	n <sub>1</sub>	n <sub>0</sub>	if (Z)=1 then (PC)←(PC)+N else (PC)←(PC)+1	1	
	BNE n (BNZ n)	0	0	0	0	1	1	P	1	1	0	n <sub>4</sub>	n <sub>3</sub>	n <sub>2</sub>	n <sub>1</sub>	n <sub>0</sub>	if (Z)=0 then (PC)←(PC)+N else (PC)←(PC)+1	1	
	BGE n	0	0	0	0	1	1	P	0	1	1	n <sub>4</sub>	n <sub>3</sub>	n <sub>2</sub>	n <sub>1</sub>	n <sub>0</sub>	if {(G)=1 or (Z)=1} then (PC)←(PC)+N else (PC)←(PC)+1	1	
	BLT n	0	0	0	0	1	1	P	1	1	1	n <sub>4</sub>	n <sub>3</sub>	n <sub>2</sub>	n <sub>1</sub>	n <sub>0</sub>	if {(G)=0 and (Z)=0} then (PC)←(PC)+N else (PC)←(PC)+1	1	
	Melody start	MSA adrs *	0	0	0	0	1	0	a <sub>8</sub>	a <sub>7</sub>	a <sub>6</sub>	a <sub>5</sub>	a <sub>4</sub>	a <sub>3</sub>	a <sub>2</sub>	a <sub>1</sub>	a <sub>0</sub>	Specifies the first address of note data. (E00 <sub>H</sub> ~FFF <sub>H</sub> )	2
Display instruction	DSP dig, REG1 *	0	0	0	1	0	0	P	dig <sub>3</sub>	dig <sub>2</sub>	dig <sub>1</sub>	dig <sub>0</sub>	r <sub>3</sub>	r <sub>2</sub>	r <sub>1</sub>	r <sub>0</sub>	digit (Low Part)←(rP), (ACC)	1	
	DSPH dig, REG1 *	0	0	0	1	0	1	P	dig <sub>3</sub>	dig <sub>2</sub>	dig <sub>1</sub>	dig <sub>0</sub>	r <sub>3</sub>	r <sub>2</sub>	r <sub>1</sub>	r <sub>0</sub>	digit (High Part)←(rP), (ACC)	1	
	DSPF dig, REG1 *	0	0	0	1	1	0	P	dig <sub>3</sub>	dig <sub>2</sub>	dig <sub>1</sub>	dig <sub>0</sub>	r <sub>3</sub>	r <sub>2</sub>	r <sub>1</sub>	r <sub>0</sub>	digit (Low Part)←(rP) via Table	2	
	DSPF dig, REG1 *	0	0	0	1	1	1	P	dig <sub>3</sub>	dig <sub>2</sub>	dig <sub>1</sub>	dig <sub>0</sub>	r <sub>3</sub>	r <sub>2</sub>	r <sub>1</sub>	r <sub>0</sub>	digit (Low Part)←(rP) via Table	2	
CPU input/output control instruction	OUT REG1, PORT	0	1	0	1	0	y <sub>4</sub>	P	y <sub>3</sub>	y <sub>2</sub>	y <sub>1</sub>	y <sub>0</sub>	r <sub>3</sub>	r <sub>2</sub>	r <sub>1</sub>	r <sub>0</sub>	(PORTy)←(rP)	1	
	OUT #i, PORT	0	1	0	1	1	y <sub>4</sub>	P	y <sub>3</sub>	y <sub>2</sub>	y <sub>1</sub>	y <sub>0</sub>	i <sub>3</sub>	i <sub>2</sub>	i <sub>1</sub>	i <sub>0</sub>	(PORTy)←i	1	
	INP PORT, REG1	0	1	0	0	0	y <sub>4</sub>	P	y <sub>3</sub>	y <sub>2</sub>	y <sub>1</sub>	y <sub>0</sub>	r <sub>3</sub>	r <sub>2</sub>	r <sub>1</sub>	r <sub>0</sub>	(rP), (ACC)←(PORTy)	1	
	NOP	0	0	0	0	0	0	0	0	0	0	0	0	0	0	0	NO Operation	1	
	HALT	0	0	0	0	0	1	0	0	1	1	1	0	0	0	0	HAIT CPU	1	

**PACKAGE DIMENSIONS**

(Unit : mm)

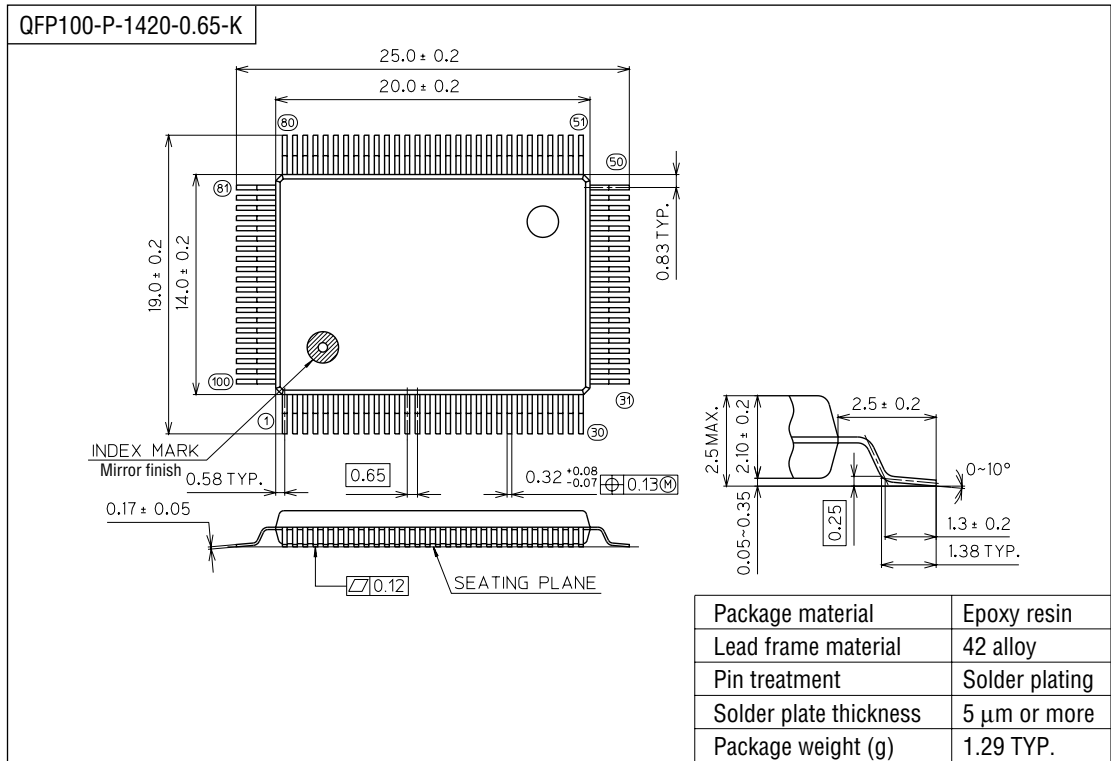

**Notes for Mounting the Surface Mount Type Package**

The SOP, QFP, TSOP, SOJ, QFJ (PLCC), SHP and BGA are surface mount type packages, which are very susceptible to heat in reflow mounting and humidity absorbed in storage. Therefore, before you perform reflow mounting, contact Oki's responsible sales person for the product name, package name, pin number, package code and desired mounting conditions (reflow method, temperature and times).

(Unit : mm)

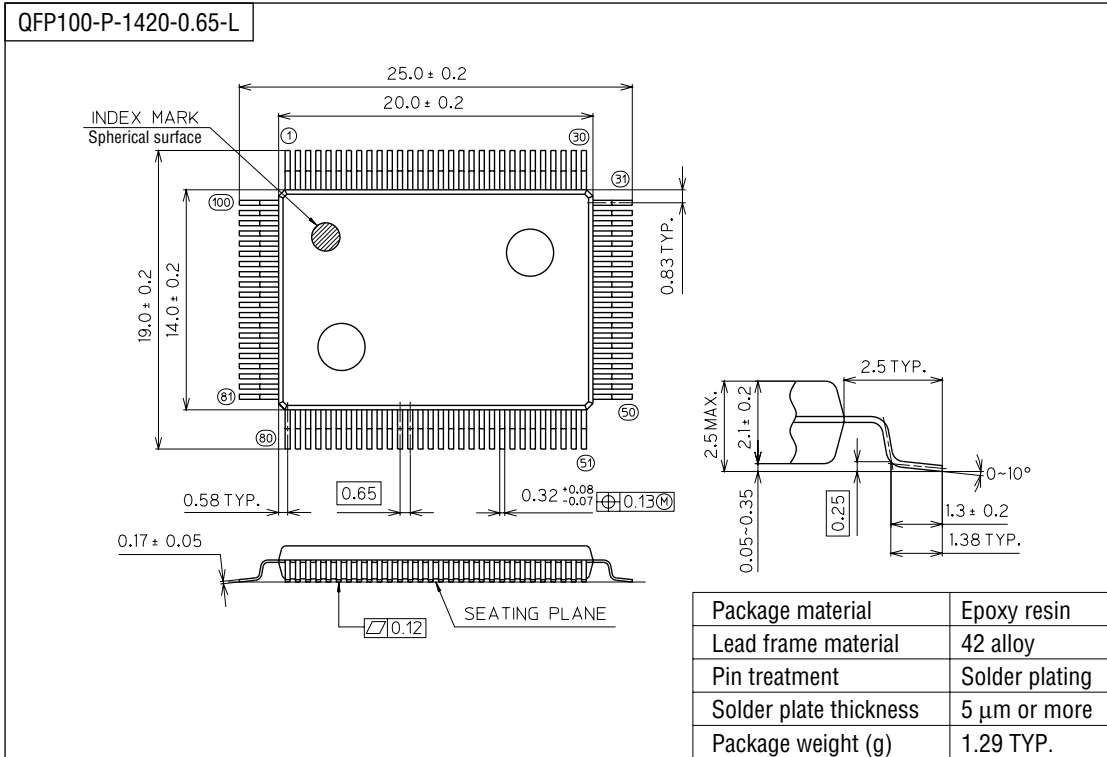

### Notes for Mounting the Surface Mount Type Package

The SOP, QFP, TSOP, SOJ, QFJ (PLCC), SHP and BGA are surface mount type packages, which are very susceptible to heat in reflow mounting and humidity absorbed in storage. Therefore, before you perform reflow mounting, contact Oki's responsible sales person for the product name, package name, pin number, package code and desired mounting conditions (reflow method, temperature and times).



(Unit : mm)

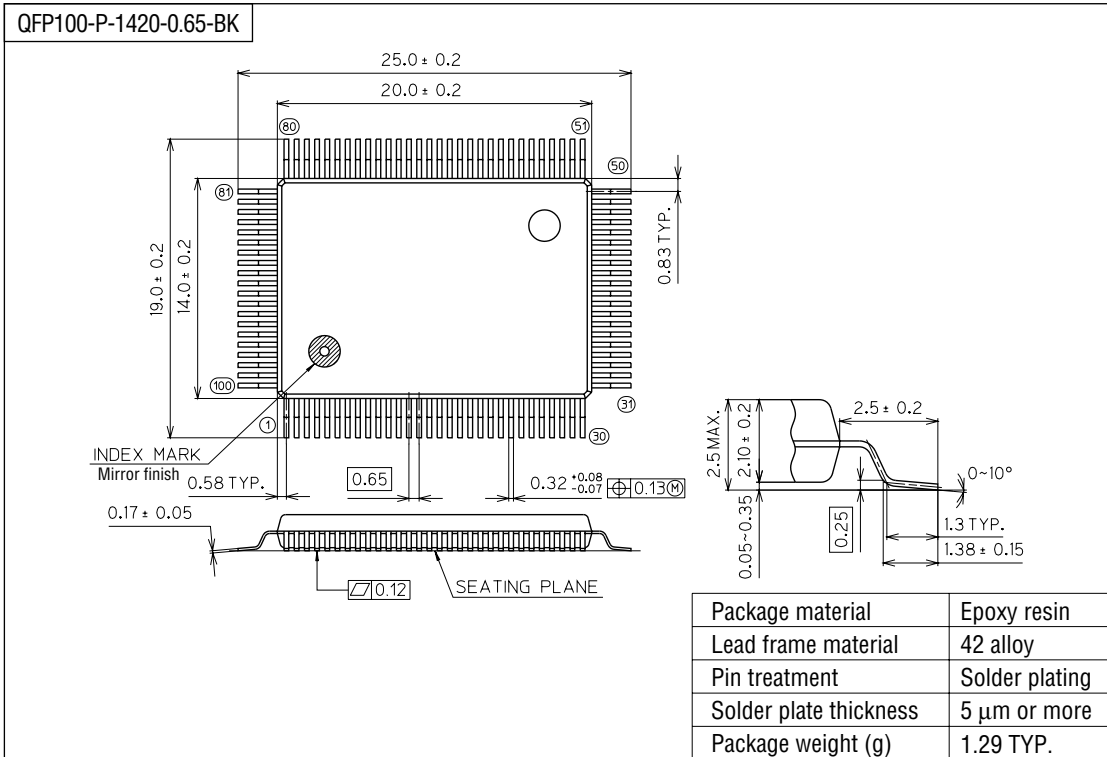

Notes for Mounting the Surface Mount Type Package

The SOP, QFP, TSOP, SOJ, QFJ (PLCC), SHP and BGA are surface mount type packages, which are very susceptible to heat in reflow mounting and humidity absorbed in storage. Therefore, before you perform reflow mounting, contact Oki's responsible sales person for the product name, package name, pin number, package code and desired mounting conditions (reflow method, temperature and times).