

OKI electronic components

KGF1183

Medium-Power Amplifier

GENERAL DESCRIPTION

The KGF1183 is a two-stage medium-power UHF-band amplifier that features high gain and high output power. The internally matched $50\ \Omega$ input eliminates external impedance-matching circuits for the input, but it requires a simple matching circuit for the output. All specifications for this device are guaranteed at 5 V and 850 MHz. Because of the high gain and high output power, the KGF1183 is ideal as a transmitter-intermediate-stage amplifier for personal handy phones.

FEATURES

- Internally matched $50\ \Omega$ input
- High linear gain: 20 dB (min.)
- High output power: 17 dBm (min.)
- Low current operation: 80 mA (max.)
- Self-bias circuit configuration with built-in source capacitor
- Package: 4PSOP

PACKAGE DIMENSIONS

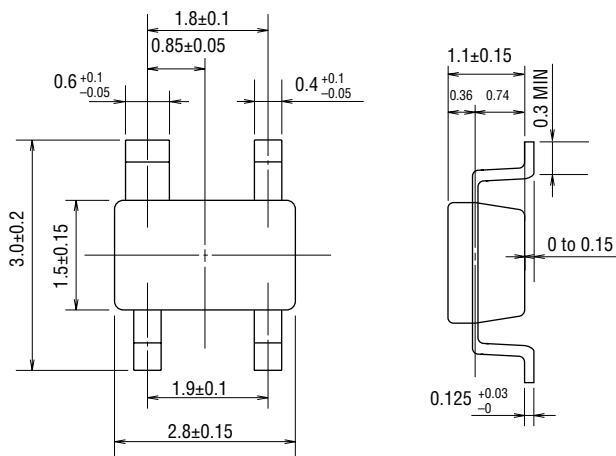

(Unit: mm)

Package material	Epoxy resin
Lead frame material	42 alloy
Pin treatment	Solder plating
Solder plate thickness	5 μm or more

MARKING

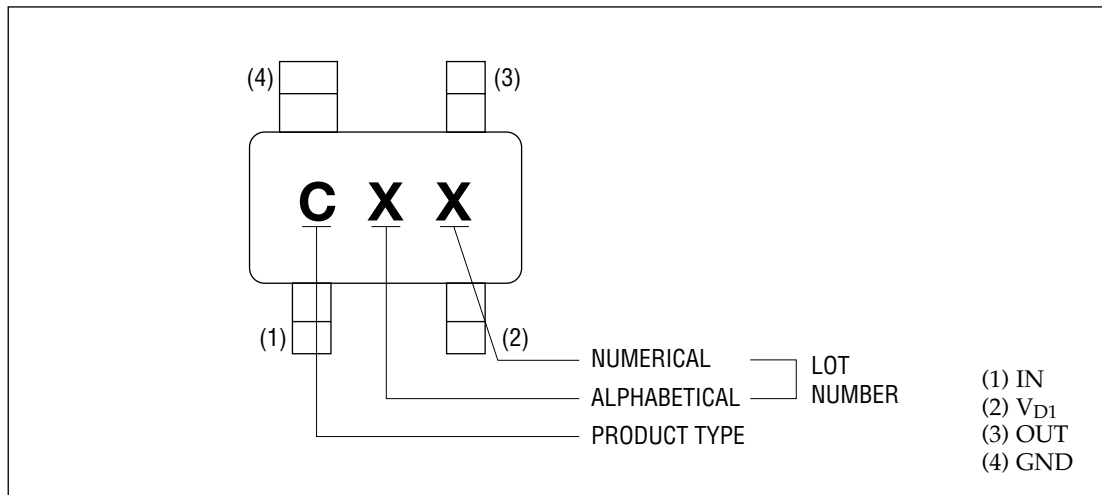

CIRCUIT

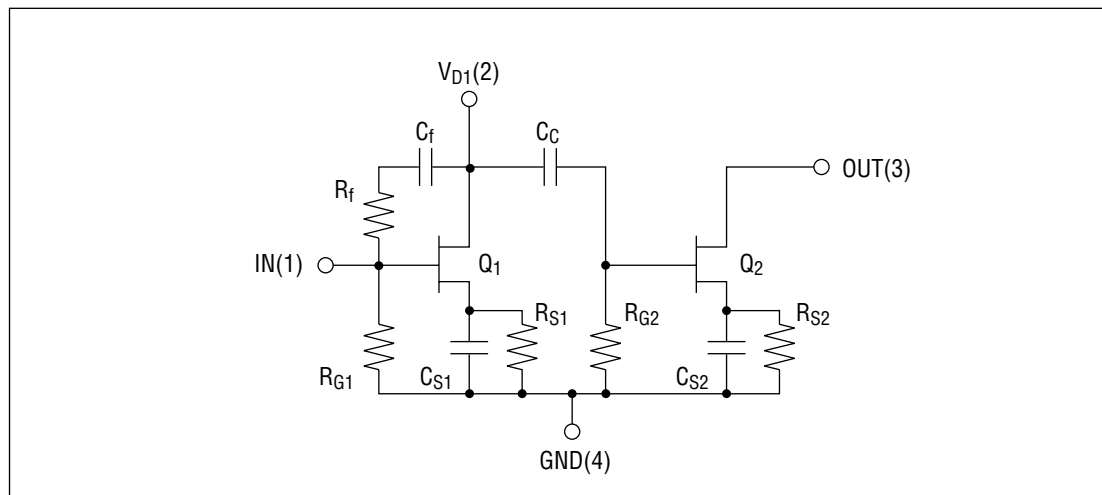

ABSOLUTE MAXIMUM RATINGS

Item	Symbol	Condition	Unit	Min.	Max.
Supply voltage	V_{DD}	$T_a = 25^{\circ}\text{C}$	V	—	10
Input power	P_{IN}	$T_a = 25^{\circ}\text{C}$	dBm	—	6
Total power dissipation	P_{tot}	$T_a = 25^{\circ}\text{C}$	mW	—	300
Channel temperature	T_{ch}	—	$^{\circ}\text{C}$	—	150
Storage temperature	T_{stg}	—	$^{\circ}\text{C}$	-45	125

ELECTRICAL CHARACTERISTICS

(Ta = 25°C)

Item	Symbol	Condition	Unit	Min.	Typ.	Max.
Operating current	I_D	(*1), $P_{IN} = 0$ dBm	mA	—	60.0	80.0
Output power	P_{O1}	(*1), $P_{IN} = 0$ dBm	dBm	17.0	—	—
Linear gain	G_{LIN}	(*1), $P_{IN} = -20$ dBm	dB	20.0	—	—
Input return loss	R_{LIN}	(*1), $P_{IN} = -20$ dBm	dB	—	-9.0	—

*1 Self-bias condition: $V_{DD} = 5.4$ V, $V_G = 0$ V, $f = 850$ MHz

RF CHARACTERISTICS

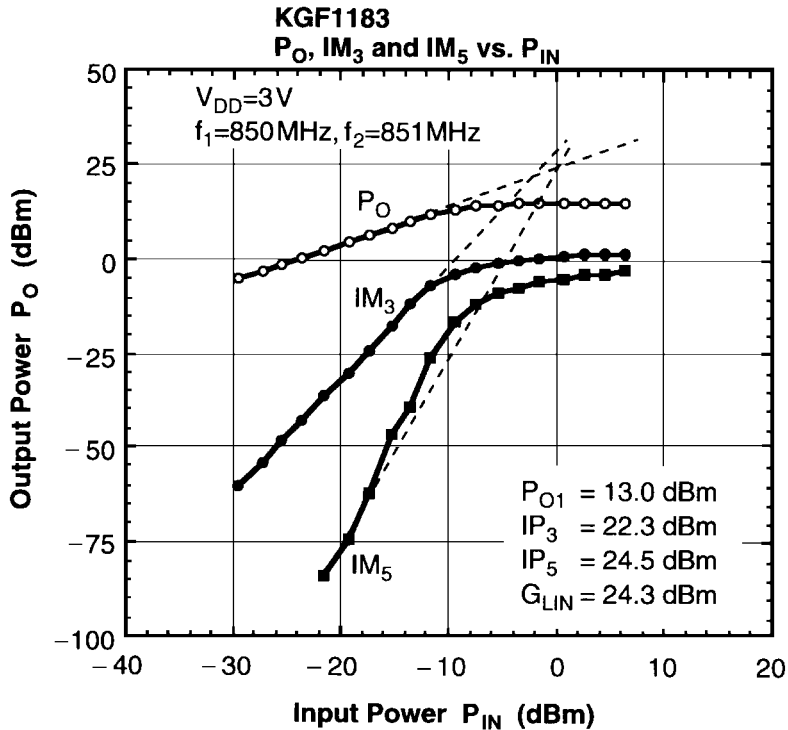
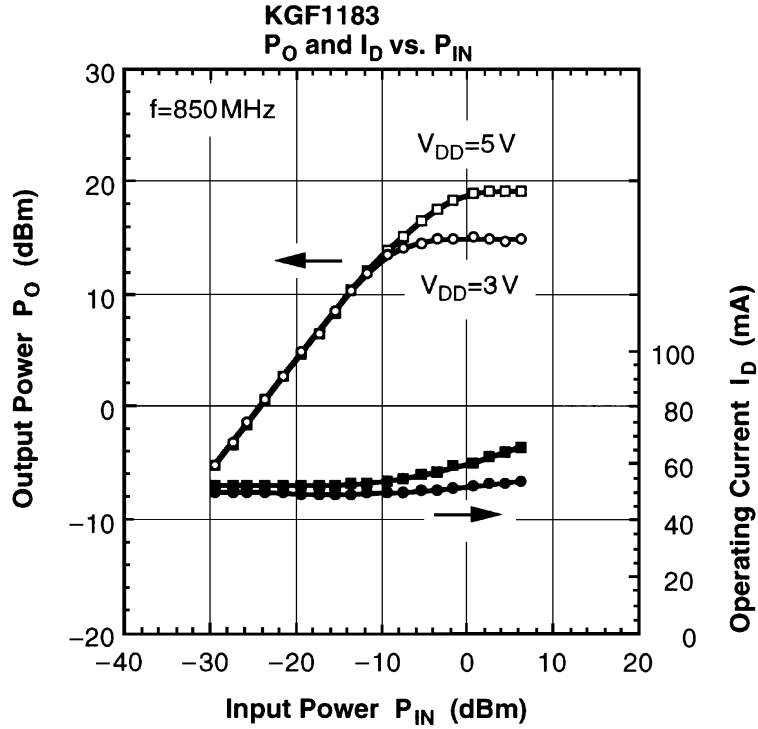

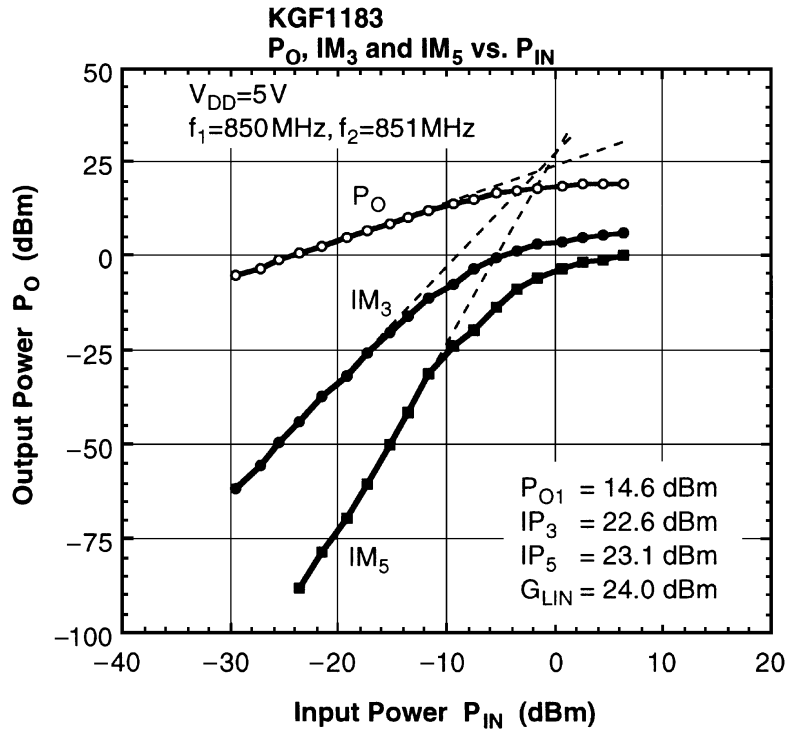

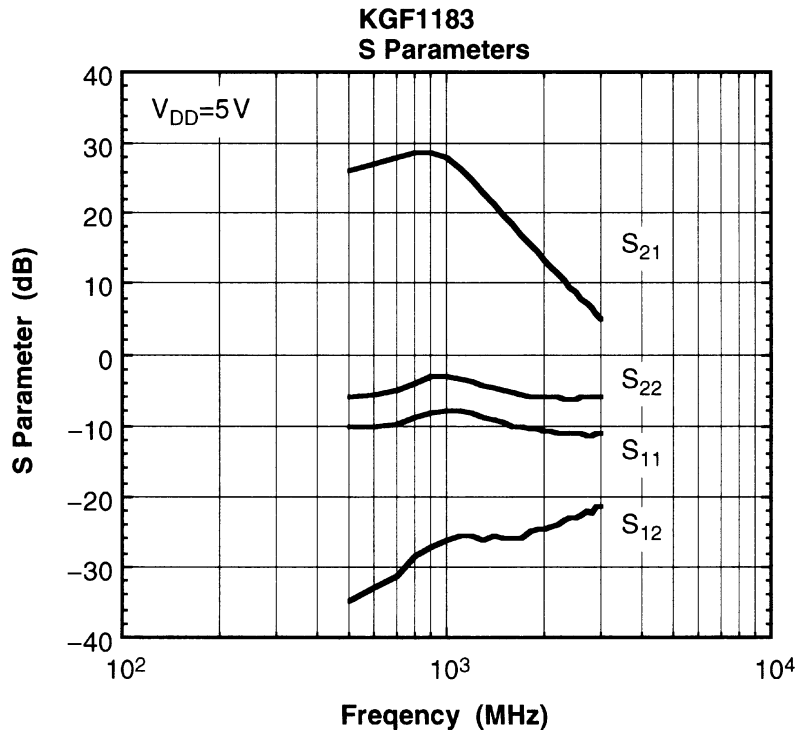
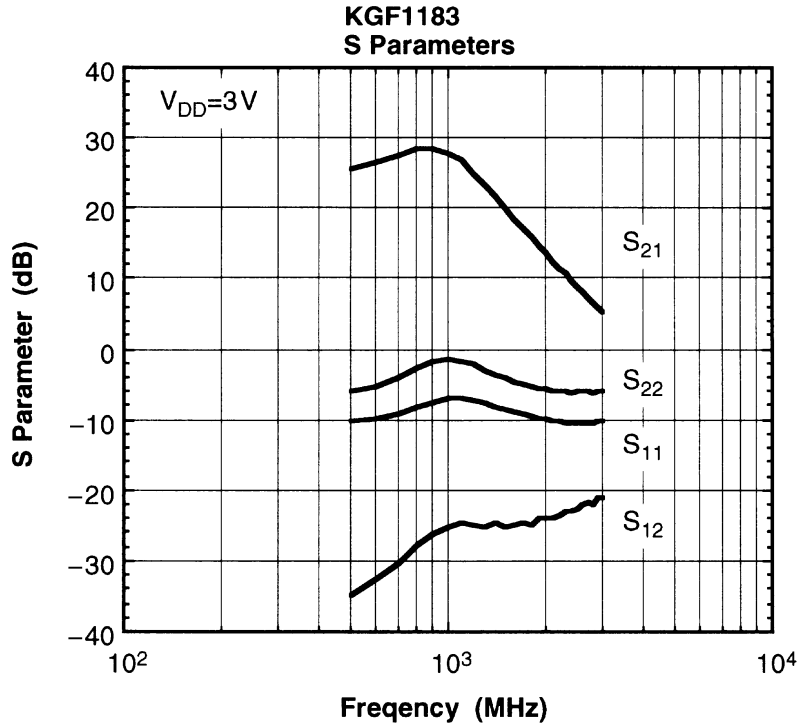

Typical S Parameters

 $V_{DD} = 3\text{ V}$, $I_D = 52.4\text{ mA}$

Freq(MHz)	MAG(S ₁₁)	ANG(S ₁₁)	MAG(S ₂₁)	ANG(S ₂₁)	MAG(S ₁₂)	ANG(S ₁₂)	MAG(S ₂₂)	ANG(S ₂₂)
500.0	0.314	-73.77	19.224	-23.89	0.018	103.91	0.497	-89.19
600.0	0.322	-92.04	21.483	-36.47	0.024	106.42	0.543	-108.09
700.0	0.343	-115.90	23.875	-51.66	0.030	104.25	0.621	-129.90
800.0	0.383	-145.41	25.956	-70.01	0.041	95.92	0.718	-154.16
900.0	0.423	-177.00	26.532	-90.60	0.049	84.93	0.807	178.21
1000.0	0.444	151.92	24.912	-112.53	0.056	71.59	0.853	150.71
1100.0	0.452	125.48	21.642	-132.14	0.059	64.47	0.830	126.58
1200.0	0.434	103.93	17.830	-148.33	0.057	59.02	0.779	108.00
1300.0	0.412	87.26	14.595	-160.93	0.054	56.85	0.706	92.39
1400.0	0.391	74.96	11.968	-170.50	0.058	55.96	0.665	80.35
1500.0	0.378	65.04	9.960	-179.14	0.055	51.34	0.628	70.27
1600.0	0.358	57.02	8.476	173.73	0.056	53.89	0.591	61.79
1700.0	0.345	49.79	7.233	167.79	0.060	50.50	0.570	55.15
1800.0	0.337	43.08	6.197	162.18	0.058	51.85	0.548	49.04
1900.0	0.329	37.48	5.454	157.26	0.063	53.39	0.533	43.45
2000.0	0.326	32.68	4.790	152.77	0.063	52.40	0.523	38.36
2100.0	0.316	26.61	4.228	148.19	0.065	49.90	0.513	33.82
2200.0	0.314	23.59	3.782	143.78	0.065	52.61	0.511	29.48
2300.0	0.306	18.36	3.391	139.98	0.071	52.15	0.500	24.80
2400.0	0.304	14.95	3.073	136.45	0.071	53.77	0.495	21.41
2500.0	0.306	10.96	2.777	133.45	0.072	54.15	0.497	18.15
2600.0	0.306	8.19	2.543	129.56	0.079	54.77	0.499	14.71
2700.0	0.299	5.88	2.337	126.43	0.082	47.98	0.498	11.73
2800.0	0.305	2.32	2.153	123.33	0.080	51.00	0.494	8.88
2900.0	0.306	-0.50	1.969	120.37	0.089	49.99	0.502	5.90
3000.0	0.309	-2.42	1.826	117.03	0.090	52.10	0.503	4.23

Typical S Parameters

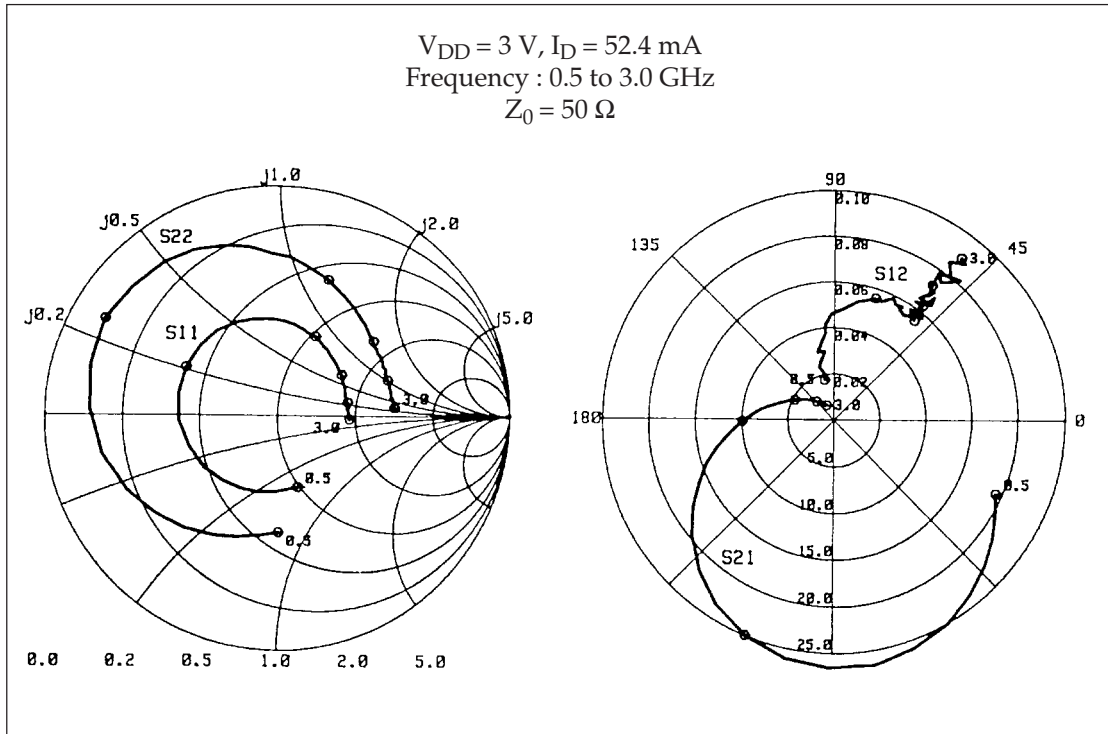

Typical S Parameters

 $V_{DD} = 5\text{ V}$, $I_D = 59.3\text{ mA}$

Freq(MHz)	MAG(S ₁₁)	ANG(S ₁₁)	MAG(S ₂₁)	ANG(S ₂₁)	MAG(S ₁₂)	ANG(S ₁₂)	MAG(S ₂₂)	ANG(S ₂₂)
500.0	0.311	-72.62	20.449	-24.73	0.018	103.61	0.502	-78.78
600.0	0.316	-91.07	22.960	-37.93	0.022	105.35	0.524	-98.88
700.0	0.329	-115.93	25.588	-54.09	0.027	104.30	0.573	-122.75
800.0	0.357	-146.89	27.665	-73.68	0.037	96.33	0.635	-150.85
900.0	0.388	179.78	27.761	-95.44	0.044	86.08	0.691	176.66
1000.0	0.400	147.73	25.369	-117.65	0.049	70.92	0.711	146.53
1100.0	0.400	120.80	21.527	-136.72	0.052	67.86	0.689	120.34
1200.0	0.382	100.26	17.527	-152.22	0.052	61.66	0.652	100.99
1300.0	0.358	85.18	14.264	-163.95	0.050	56.88	0.606	84.56
1400.0	0.344	72.14	11.683	-173.03	0.052	61.57	0.582	72.49
1500.0	0.331	62.96	9.725	178.84	0.051	57.39	0.554	62.52
1600.0	0.316	55.47	8.284	171.93	0.051	58.63	0.537	54.24
1700.0	0.308	48.64	7.102	166.11	0.050	54.46	0.523	47.76
1800.0	0.301	42.07	6.073	160.60	0.056	52.69	0.513	41.90
1900.0	0.296	37.46	5.356	155.85	0.059	58.46	0.503	36.50
2000.0	0.291	32.35	4.699	151.14	0.059	53.42	0.500	31.17
2100.0	0.286	27.68	4.159	147.16	0.061	55.83	0.499	26.72
2200.0	0.283	22.88	3.720	142.47	0.063	57.68	0.500	22.85
2300.0	0.276	18.39	3.346	138.93	0.068	56.74	0.493	19.15
2400.0	0.276	15.62	3.023	135.93	0.072	57.15	0.493	16.08
2500.0	0.277	12.64	2.729	132.24	0.072	56.20	0.491	12.60
2600.0	0.278	9.04	2.511	128.36	0.075	53.27	0.500	9.73
2700.0	0.272	6.80	2.312	125.53	0.080	53.50	0.504	6.98
2800.0	0.274	3.45	2.110	122.37	0.077	56.57	0.499	4.55
2900.0	0.283	0.55	1.925	119.21	0.086	52.11	0.507	1.76
3000.0	0.281	-1.23	1.799	115.84	0.086	53.99	0.512	-0.19

Typical S Parameters

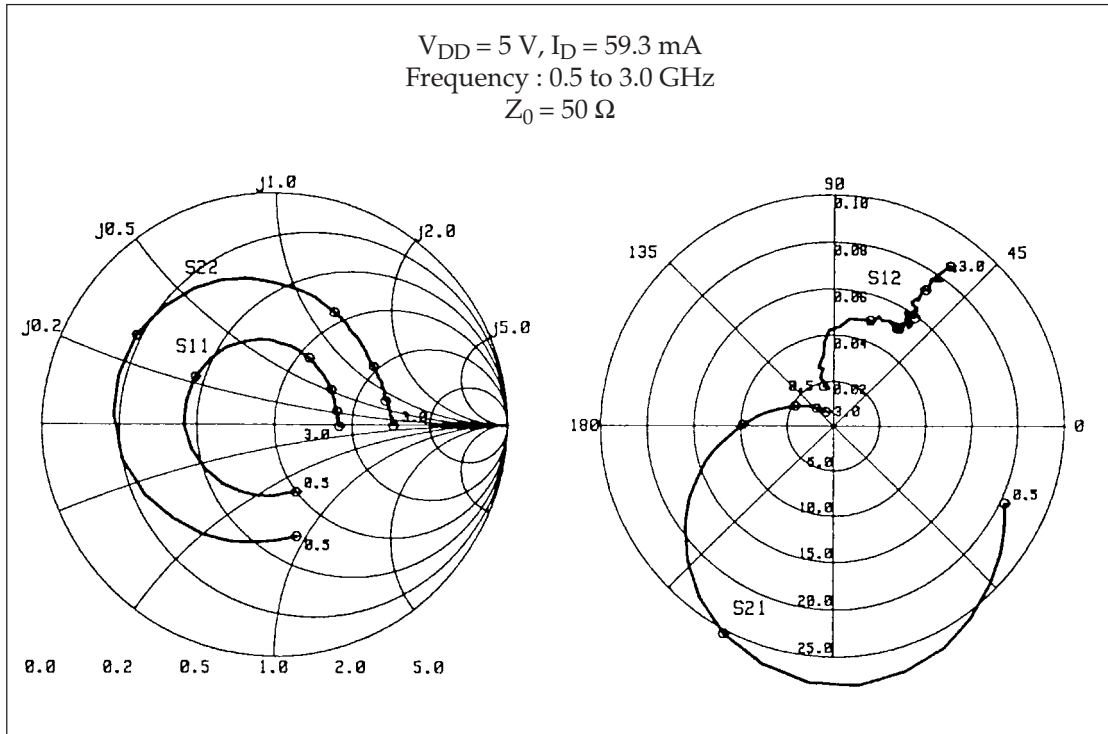

Test Circuit and Bias Configuration for KGF1183

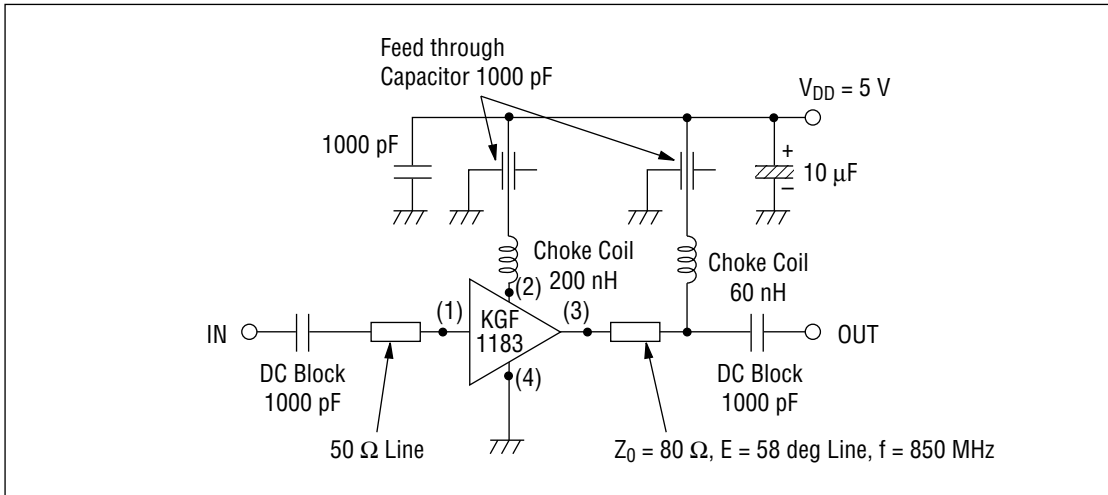

Test Circuit Board for KGF 1183

