

JOB60851 Starter Kit

User's Manual

Version 1.07 (July 27, 2000)

Oki Electric Industry Co., Ltd..

Technocollage Inc

NOTICE

1. The information contained herein can change without notice owing to product and/or technical improvements. Before using the product, please make sure that the information being referred to is up-to-date.
2. The outline of action and examples for application circuits described herein have been chosen as an explanation for the standard action and performance of the product. When planning to use the product, please ensure that the external conditions are reflected in the actual circuit, assembly, and program designs.
3. When designing your product, please use our product below the specified maximum ratings and within the specified operating ranges including, but not limited to, operating voltage, power dissipation, and operating temperature.
4. Oki assumes no responsibility or liability whatsoever for any failure or unusual or unexpected operation resulting from misuse, neglect, improper installation, repair, alteration or accident, improper handling, or unusual physical or electrical stress including, but not limited to, exposure to parameters beyond the specified maximum ratings or operation outside the specified operating range.
5. Neither indemnity against nor license of a third party's industrial and intellectual property right, etc. is granted by us in connection with the use of the product and/or the information and drawings contained herein. No responsibility is assumed by us for any infringement of a third party's right which may result from the use thereof.
6. The products listed in this document are intended for use in general electronics equipment for commercial applications (e.g., office automation, communication equipment, measurement equipment, consumer electronics, etc.). These products are not authorized for use in any system or application that requires special or enhanced quality and reliability characteristics nor in any system or application where the failure of such system or application may result in the loss or damage of property, or death or injury to humans.
Such applications include, but are not limited to, traffic and automotive equipment, safety devices, aerospace equipment, nuclear power control, medical equipment, and life-support systems.
7. Certain products in this document may need government approval before they can be exported to particular countries. The purchaser assumes the responsibility of determining the legality of export of these products and will take appropriate and necessary steps at their own expense for these.
8. No part of the contents contained herein may be reprinted or reproduced without our prior permission.

Copyright 2000 Oki Electric Industry Co., Ltd.

Contents

1. Introduction	1-1
1-1. Cheking Packing List	1-2
1-2. Host Environment	1-3
1-3. Precaution for Safe and Proper Use	1-4
2. Putting Board through its Paces	2-1
2-1. Setup	2-2
2-1-1. Configuring JOB60851 Board.....	2-2
2-1-2. Installing Development Software	2-3
2-1-3. Connecting Board	2-4
2-2. Running Default Program	2-4
2-2-1. Installing USB Driver.....	2-4
2-2-2. Running Flash Memory Program.....	2-4
2-3. Running User Programs	2-6
2-3-1. Connecting Serial Cable	2-7
2-3-2. Loading Terminal Emulator.....	2-7
2-3-3. Synchronizing Link.....	2-8
2-3-4. Downloading and Executing	2-8
2-4. Overwriting Flash Memory Contents	2-9
3. System Specifications.....	3-1
3-1. System Components.....	3-2
3-1-1. System Objective	3-2
3-1-2. System Components.....	3-2
3-2. Hardware Specification	3-3

3-2-1. Connectors and Switches.....	3-3
3-2-2. Circuit Diagram	3-5
3-2-3. Parts List.....	3-7
3-2-4. Memory Maps	3-8
3-3. System Limitations.....	3-12
3-3-1. Resources Uses	3-12
4. Software Development	4-1
4-1. USB Basics	4-2
4-1-1. Bus Topology, Addresses, and Hot Plugging.....	4-2
4-1-2. Specification Documents	4-3
4-1-3. Core Specifications.....	4-3
4-1-4. Data Flow Types.....	4-4
4-1-5. Bus Transactions	4-4
4-1-6. Packets	4-5
4-1-7. Endpoints	4-5
4-1-8. Data Rates	4-6
4-1-9. Device Class Specifications	4-6
4-1-10. Device Requests.....	4-7
4-1-11. Standard Device Requests.....	4-7
4-1-12. Device Descriptors.....	4-8
4-2. Sample USB Firmware	4-10
4-2-1. Setup.....	4-10
4-2-2. Sample Firmware Specifications	4-10
4-2-3. Sample USB Host Software	4-11
4-2-4. Compiling and Execitomg Sample USB Firmware.....	4-11
4-2-5. Confirming USB Compliance with Usbcheck.exe	4-11
4-2-6. Creating USB Mouse Demo	4-13
4-2-7. Modifying Application Layer.....	4-14

4-2-8. Simple Debugging.....	4-16
4-2-9. Evaluating USB Equipment	4-16
4-3. USB Bits and Pieces	4-17
4-3-1. Device Controller Specifications.....	4-17
4-3-2. Overview of ML60851C Operation	4-17
4-3-3. Connecting Microcontroller to USB Controller.....	4-18
4-3-4. Special USB Considerations.....	4-19
4-3-5. Building a Product.....	4-20
4-3-6. Vendor and Product IDs	4-20
4-3-7. Other Tools Necessary	4-20
4-3-8. Note on Porting	4-21
4-3-9. Limitations	4-22
4-4. Port 7 LED2 Control	4-22
4-4-1. Port 7 Registers	4-22
4-4-2. Changing LED2 Color	4-23
4-5. Standard I/O over Serial Link.....	4-26
4-5-1. JOB60851 Board Standard I/O.....	4-26
4-5-2. Serial Port	4-27
4-5-3. read() and write() Functions.....	4-29
4-5-4. Standard I/O Examples.....	4-31
4-5-5. Debugging with Standard I/O.....	4-32

1. Introduction

1-1. Checking Packing List

Thank you for purchasing the JOB60851 Starter Kit.

The JOB60851 Starter Kit drives an Oki Electric Industry ML60851 Universal Serial Bus (USB) device controller with an Oki MSM66Q573 microcontroller to create a starting point for developing products with built-in USB support. The kit also includes sample firmware source code and the C compiler package for the Oki MSM66 microcontroller Series, so the developer can start writing firmware right away.

Before starting development, however, check the kit contents against the packing list in Table 1.1.1. If a component is missing or damaged during shipping, please contact your Oki Electric distributor or Technocollage and include the JOB60851 serial number. Replacement is free within one (1) month of delivery.

Table 1.1.1. Packing List

JOB60851	1
USB cable	1
RS-232c cable	1
AC adapter	1
CD-ROM	1
Two 60-pin user connectors	2
Introduction (this page)	1

The CD-ROM contains the following directories and files.

\Document	Documentation
\CC665S	C compiler User's Manual, etc.
\JOB60851	JOB60851 Starter Kit User's Guide, etc.
\M66573	MSM66573 User's Guide, etc.
\ML60851C	USB controller documentation, etc.
\Package	Compiler package and sample source code
\Cc665s	C compiler package, etc.
\Host	Sample files for evaluating USB operation, etc.
\Sample	Sample programs, etc.
\Usb_firm	Sample source code for MSM60851C control software: Hot plugging (a.k.a. dynamic insertion and removal) capability for USB device, loopback test, etc.

Before using this product, read through to the end of this section ("Introduction"). Detailed descriptions start in Section 2 "Putting Board through Its Paces."

If a component is missing or damaged during shipping, please contact your Oki Electric distributor with the included JOB60851 serial number. Replacement is free within one month of delivery.

Technical support for this product is limited to the product description. We do not offer personalized support in Japanese or English, not by e-mail or fax and especially not over the telephone.

1-2. Host Environment

The JOB60851 Starter Kit assumes the following development environment.



- Microsoft Windows 98
- USB interface fully compatible with Microsoft Windows 98 USB driver
- Terminal emulation software

The compiler package will also run under Microsoft Windows 95 and MS-DOS version 5.0 or later, but the JOB60851 board will not be accessible as a USB device.

1-3. Precaution for Safe and Proper Use

This User's Guide uses various labels and icons that serve as your guides to operating this product safely and properly so as to prevent death, personal injury, and property damage. The following table lists these labels and their definitions.

Labels

 Warning	<p>This label indicates precautions that, if ignored or otherwise not completely followed, could lead to death or serious personal injury.</p>
 Caution	<p>This label indicates precautions that, if ignored or otherwise not completely followed, could lead to personal injury or property damage.</p>

Icons



A triangular icon draws your attention to the presence of a hazard. The illustration inside the triangular frame indicates the nature of the hazard—in this example, an electrical shock hazard.









A circular icon with a solid background illustrates an action to be performed. The illustration inside this circle indicates this action—in this example, unplugging the power cord.











A circular icon with a crossbar indicates a prohibition. The illustration inside this circle indicates the prohibited action—in this example, disassembly.

Please read this page before using the product.

 Warning	
Use only the specified voltage. Using the wrong voltage risks fire and electrical shock.	
At the first signs of smoke, an unusual smell, or other problems, unplug the emulator and disconnect all external power cords. Continued use risks fire and electrical shock.	
Do not use the product in an environment exposing it to moisture or high humidity. Such exposure risks fire and electrical shock.	
Do not pile objects on top of the product. Such pressure risks fire and electrical shock.	
At the first signs of breakdown, immediately stop using the product, unplug the emulator, and disconnect all external power cords. Continued use risks fire and electrical shock.	

Chapter 1 Introduction

Please read this page before using the product.

 Caution	
<p>Do not use this product on an unstable or inclined base as it can fall or overturn, producing injury.</p>	
<p>Do not use this product in an environment exposing it to excessive vibration, strong magnetic fields, or corrosive gases. Such factors can loosen or even disconnect cable connectors, producing a breakdown.</p>	
<p>Do not use this product in an environment exposing it to temperatures outside the specified range, direct sunlight, or excessive dust. Such factors risk fire and breakdown.</p>	
<p>Use only the cables and other accessories provided. Using non-compatible parts risks fire and breakdown.</p>	
<p>Always observe the specified order for turning equipment on and off. Using the incorrect order risks fire and breakdown.</p>	
<p>Do not use the cables and other accessories provided with other systems. Such improper usage risks fire.</p>	
<p>Before connecting or disconnecting the cables and the accessories, the power source for the emulator must be turned OFF. Connections or disconnections performed while the power source is ON risk fire and damage to the system.</p>	

Notation

This manual utilizes the following notational conventions for convenience.

- | | |
|--------------------------------|---|
| ■ Caution ■ | A “caution” indicates a section of the manual that requires special attention. |
| ■ Reference ■ | A “reference” provides information related to the current topic and indicates the page number of a related section of the manual. |
| ■ Application Example ■ | An “application example” indicates an example related to the current topic. |
| (note ×) | “(note ×)” is a reference to a numbered note that provides supplementary information lower on the same page. |
| ■ Note x ■ | “Note x:” provides supplementary information related to the passage marked with “(note ×).” |

The descriptions below indicate keyboard keys with capitalized names inside angle brackets.

Examples

<Enter>	Enter (or Return) key
<Space>	Space key
<Ctrl>	Control key (left or right)
<Shift>	Shift key (left or right)

2. Putting Board through Its Paces

Chapter 2 Putting Board through its Paces

2-1. Setup

2-1-1. Configuring JOB60851 Board

Make sure that the switches and jumpers numbered 4, 7, 8, and 9 in Figure 2.1.1 are all in their factory default positions, B.

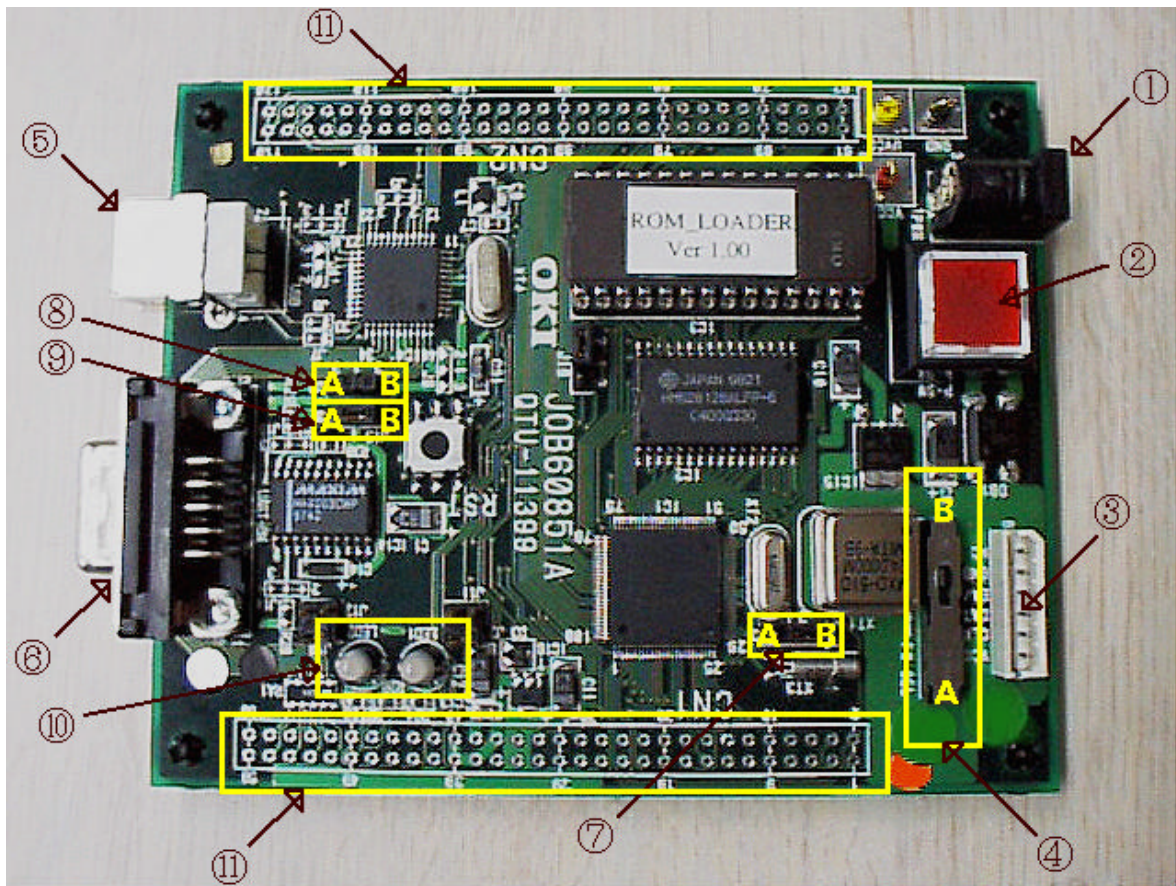

Figure 2.1.1. JOB60851 Board, Top View

- | | |
|--|-------------------------------------|
| (1) AC adapter jack | (6) Serial (RS-232C) connector |
| (2) Power switch | (7) Clock selection jumper |
| (3) Flash writer connector | (8) Power supply jumpers |
| (4) Flash writer selection switch (FW-SEL) | (9) Power supply jumpers |
| (5) USB connector | (10) Indicator LEDs (LED1 and LED2) |
| | (11) User connectors (CN1 and CN2) |

2-1-2. Installing Development Software

(1) Install CC665S compiler package

1. Create a directory for the package--c:\665s, for example.
2. Copy the contents of the CD-ROM directory \package\cc665s to that directory.
readme.txt
c665spak.exe
mac66k.exe
rtl665s.exe
tgt665s.exe
3. In an MS-DOS compatibility box, switch to the above directory and run the .EXE files, self-expanding archives that automatically extract compiler files to the appropriate subdirectories.

```
C:\665s>c665spak.exe      <Enter>
C:\665s>mac66k.exe       <Enter>
C:\665s>rtl665s.exe     <Enter>
C:\665s>tgt665s.exe     <Enter>
```

(2) Configure environment

1. Make a copy of the standard Windows 9x .PIF file for opening an MS-DOS window and rename it 665s--665s.pif if you have Explorer set to display file extensions.
2. Create a work directory--c:\test, for example.
3. Using a text editor, create the following batch file in the work directory--c665.bat, for example. (Modify the c:\665s portions as necessary.)

```
set path=\665s;c:%path%
set INCL66K=c:\665s\INCLUDE
set LIB66K=c:\665s\LIB
```

4. Display the Properties for the .PIF file created above, click the Program tab, and set the Work directory and Batch file fields to the names used above.

```
c:\test
c:\test\c665s.bat
```

5. Press <Enter> to save the changes.

(3) Copy sample executables

Copy the contents of the CD-ROM directory \package\sample to the work directory created above.

The software installation is now complete.

■ Note ■

The above procedures assume that the compiler package is installed in the directory \665s on drive C:. If you wish to locate this directory on another drive or even change both drive and directory, simply change all occurrences of c:\665s above to the name of the new directory.

2-1-3. Connecting Board

This section gives the procedures for preparing the JOB60851 board for connection to the development host.

1. Make sure that the Flash writer selection switch (FW-SEL, #4 in Figure 2.1.1) is in its B position.
2. Plug the AC adapter into the jack (#1 in Figure 2.1.1) on the board. Make sure that the power (#2 in Figure 2.1.1) is OFF.
3. Plug one end of the USB cable into the connector (#5 in Figure 2.1.1) on the board. Connect the other end into the host controller.

2-2. Running Default Program

This section gives the procedures for running the program shipped in the MSM66Q573 Flash memory.

2-2-1. Installing USB Driver

The included CD-ROM includes the necessary USB driver as well as host software, used in the next Section, for testing bulk data flow.

1. Create a directory for the host software--c:\usb, for example.
2. Copy the contents of the CD-ROM directory \package\host to that directory.
Rwbulk.exe
Bulkusb.sys
Bulkusb.inf
3. Connect the JOB60851 board as described in Section 2.1.3 above and apply power to it.
4. When Windows 98 automatically detects the new device, install the driver using the Windows 98 driver wizard. (Have the Windows 98 CD-ROM or CABs handy.)

2-2-2. Running Flash Memory Program

The JOB60851 Starter Kit ships with a program already in the MSM66Q573 Flash memory. The executable Rwbulk.exe installed above is for transferring data to and from this program.

1. Open an MS-DOS window and change to the directory containing Rwbulk.exe--c:\usb in our example.

```
C:\usb>rwbulk.exe <Enter>
```

2. Run Rwbulk.exe to display the built-in help screen.

```
Usage for RwBulk:  
RwBulk type [options]  
type : INFO -- dump USB configuration and pipe info  
        BULK -- Read/Write test  
        DESC -- Get Descriptor test  
        CLASS -- Class Request test
```

VENDOR -- Vendor Request test

Detail Usage for -? option:

```
RwBulk INFO -?
RwBulk BULK -?
RwBulk DESC -?
RwBulk CLASS -?
RwBulk VENDOR -?
```

Examples:

```
RwBulk -u
RwBulk DESC 03 00 00 00FF
RwBulk -o Pipe00 -fo out.dat -vl 2
RwBulk -i 1 -r 8192 -fi in.dat -vl 2
RwBulk VENDOR NONE DEVICE -r 00 -v 0000 -i 0000 -l 0000
```

3. Use the -u command line option to view the USB pipe numbers.

```
C:\usb>rwbulk.exe BULK -? <Enter>
```

Usage for Read/Write test:

```
RwBulk [BULK] [-options]
-i [s] where s is the input pipe
-o [s] where s is the output pipe
-r [n] where n is number of bytes to read
-w [n] where n is number of bytes to write
-fi [fn] where fn is a filename for the input pipe
-fo [fn] where fn is a filename for the output pipe
-vl [n] where n is verbose level(0,2,5, default=2)
-c [n] where n is number of iterations (default=1, 0 is infinity)
```

The options and the meanings are:

-i [s]	To specify the input pipe name the device(JOB60851) to the host direction.
-o [s]	To specify the output pipe name the host to the device(JOB60851) direction.
-r [n]	To activate operation of n-bytes read from the input pipe
-w [n]	To activate operation of n-byte write into the output pipe.
-fi [fn]	To specify a file name for bulk in operation using the input pipe.
-fo [fn]	To specify a file name for data bulkout operation using bulk out pipe.
-vl [n]	To specify verbose level as 0, 2 ro 5
-c [n]	To specify the number of iterations of specified write and read operations

3. Use the -u command line option to view the USB pipe numbers.

```
C:\usb>rwbulk.exe -u <Enter>
```

Chapter 2 Putting Board through its Paces

"USB_ENDPOINT_DESCRIPTOR for Pipe00"

"USB_ENDPOINT_DESCRIPTOR for Pipe01"

"USB_ENDPOINT_DESCRIPTOR for Pipe02"

The software defines three pipes, PIPE00 to PIPE02. The first is for output--that is, from the development host to the JOB60851 board. The other two are for input (in the opposite direction).

PIPE00→OUTPUT:PC→From host to JOB60851

PIPE01→INPUT:JOB60851→To host from JOB60851

PIPE02→INPUT:JOB60851→To host from JOB60851

4. Try one data transfer in each direction.

```
C:\USB>rwbulk.exe -o PIPE00 -w 1024 -i PIPE01 -r 1024
<Enter>
```

This command line writes one kilobyte of test data using output pipe PIPE00 and then reads the same amount of data using input pipe PIPE01.

The following messages appear if both operations are successful.

```
Device Opened successfully.
<pipe00> W (tot:1024 @ 17:04:16) : req 1024 - 1024 written
<pipe01> R (tot:1024 @ 17:04:16) : req 1024 - 1024 read
```

5. Try multiple transfers.

```
C:\USB>rwbulk.exe -o PIPE00 -w 1024 -i PIPE01 -r 1024 -c 10
<Enter>
```

This command line adds a repeat count of ten, so should produce ten such message pairs.

Opened successfully.

```
Device Opened successfully.
<pipe00> W (tot:1024 @ 17:21:07) : req 1024 - 1024 written
<pipe01> R (tot:1024 @ 17:21:07) : req 1024 - 1024 read
:
:
<pipe00> W (tot:9216 @ 17:21:07) : req 1024 - 1024 written
<pipe01> R (tot:9216 @ 17:21:07) : req 1024 - 1024 read
<pipe00> W (tot:10240 @ 17:21:07) : req 1024 - 1024 written
<pipe01> R (tot:10240 @ 17:21:07) : req 1024 - 1024 read
```

6. Additional operation

For more detailed operation please refer to readme.txt file in host driver (Package\Host) directory.

2-3. Running User Programs

This section gives the procedures for downloading a program over a serial link to the JOB60851 board and then running it.

Chapter 2 Putting Board through its Paces

Speed	38,400 b/s
Word size	8 bits
Parity check	None
Stop bits	2
Flow control	None

(3) Activating JOB60851 board

Once the terminal emulator is configured, turn on the power (#2 in Figure 2.1.1).

2-3-3. Synchronizing Link

Before communicating with the JOB60851 board, check that it and the development host are using the same data transfer speed by downloading the file !zero.dat in the work directory--c:\test in our example.

(1) Using HyperTerminal

1. Choose the Transfer menu's Send text file command.
2. In the dialog box that appears, double-click the file !zero.dat.
3. Wait for the response OK indicating synchronization.

(2) Using Tera Term Pro

1. Choose the File menu's Send file command.
2. In the dialog box that appears, make sure that the Binary option in the lower left corner is selected and double-click the file !zero.dat.
3. Wait for the response OK indicating synchronization.

2-3-4. Downloading and Executing

Next repeat the above procedure with the precompiled "Hello world!" program (main.hex) in the work directory--c:\test in our example.

(1) Using HyperTerminal

1. Choose the Transfer menu's Send text file command.
2. In the dialog box that appears, double-click the file main.hex.
3. Wait for the response "Hello World" indicating successful downloading and execution.
4. To terminate communications, close the window and answer "Yes" to the query asking permission to break the link.
5. Answering "Yes" to the query asking whether to save the session saves the current settings under the name first entered or selected above in Section 2.3.2 for reuse next time.

(2) Using Tera Term Pro

1. Choose the File menu's Send file command.
2. In the dialog box that appears, make sure that the Binary option in the lower left corner is selected and double-click the file main.hex.
3. Wait for the response "Hello World" indicating successful downloading and execution.

(3) Compiling, downloading, and executing a program

The above procedures simply download a precompiled program that was ready to run. Now it is time to compile an actual user program. By way of illustration, the following simply modifies

the above program to display a different string.

1. Copy the source code main.c to a new name, test.c, in the work directory--c:\test in our example.

2. Open the copy in a text editor.

```
#include <stdio.h>
#include <stdlib.h>
#include <m66573.h>
```

```
void main(void)
{
    std_init_573();
    S0BUF = 0x0A; /* 1st byte send to get transmit ready status */
    printf_c("Hello World!! \n");
    for(;;);
}
```

3. Modify the string in line 10, replacing "World" with your own name.
4. Save the modified version. Exit or minimize the text editor.
5. Double-click the 665s.pif icon and enter the following command line to compile the new version into test.hex, an executable for downloading to the JOB60851 board.

■ Note ■

Case counts for command line options (/T, /WIN, and /H here), but not for the command name (cl665s) or file names.

6. Repeat the appropriate download procedure above substituting the new program, test.hex, for main.hex.
7. Wait for your name to appear.

2-4. Overwriting Flash Memory Contents

As already mentioned in Section 2.2 above, the board ships with a test program in the MSM66Q573 Flash memory. This may be overwritten, however, with a PW66K Flash programmer.

For further details about flash programmer, contact Oki Electric Device Sales or distributor.

3. System Specifications

3-1. System Components

3-1-1. System Objective

The JOB60851 board's primary objective is lowering the threshold for developing new USB devices.

3-1-2. System Components

The JOB60851 board has the components shown in Figure 3.1.1.

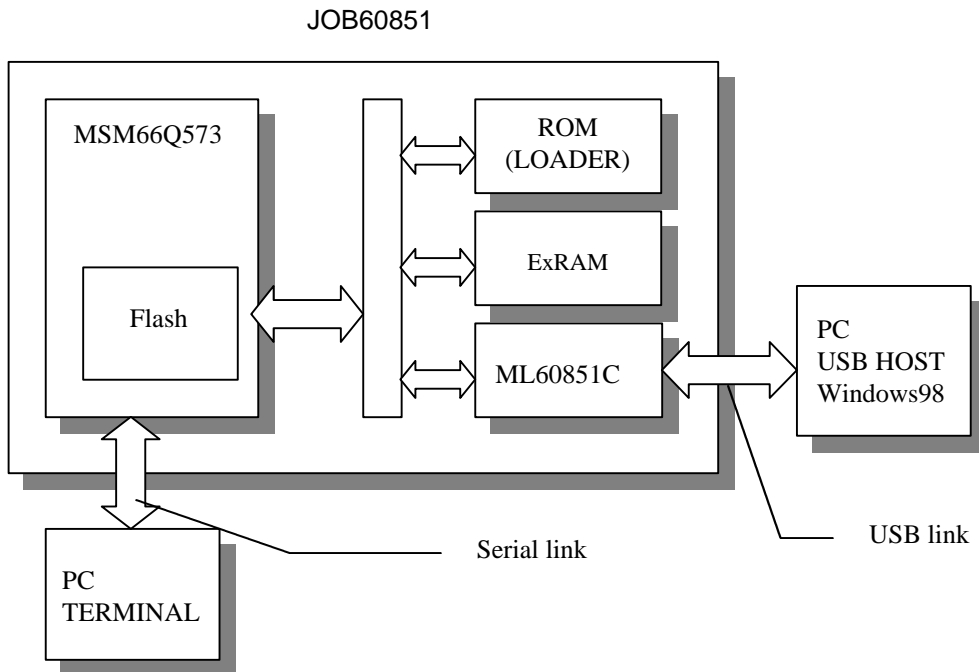

Figure 3.1.1. System Block Diagram

3-2. Hardware Specification

3-2-1. Connectors and Switches

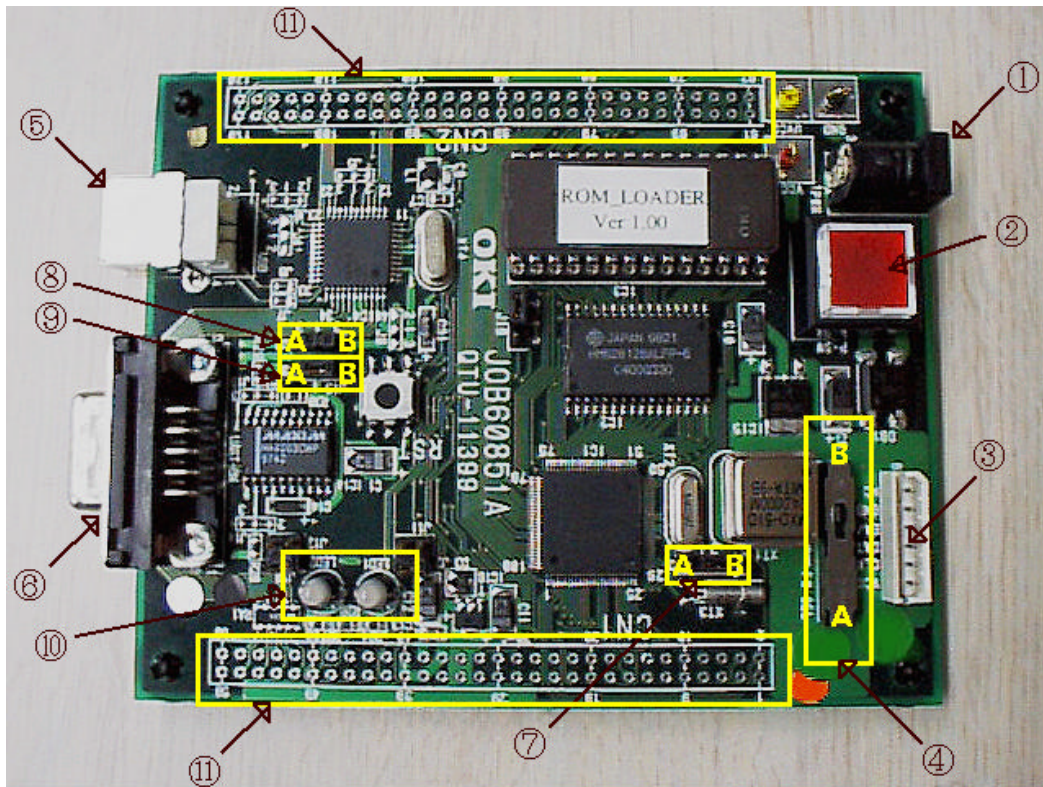

Figure 3.2.1. JOB60851 Board, Top View

(1) AC adapter jack

The included AC adapter has the following specifications.

Input:	100 V AC, 50/60 Hz, 18 VA
Output:	10 V DC, 850 mA

■ Note ■

Use only the AC adapter included with the product.

(2) Power switch

Pressing this switch alternately turns the power to the board on and off. If the indicator fails to light, check the AC adapter connections.

(3) Flash writer connector

This set of pins connects to the PW66K Flash writer for rewriting the program in the MSM66Q573 Flash memory. For further details, contact Oki Electric Device Sales at +81-3-5445-6027.

Chapter 3 System Specifications

(4) Flash writer selection switch (FW-SEL)

The B side of this switch is for executing the program in the MSM66Q573 Flash memory or overwriting it with the PW66K Flash writer (available separately).

(5) USB connector

This Series B connector is for the USB cable.

(6) Serial (RS-232C) connector This 9-pin female DSUB connector is for the RS-232C cable linking the JOB60851 board to a terminal emulator running on the host personal computer.

■ Note ■

Always include the JOB60851 serial number with any queries. It is printed in black ink on the underside of the board, near the serial connector.

(7) Clock selection jumper

This jumper offers a choice of two onboard MSM66Q573 microcontroller system clock frequencies: 16 (A) and 24 (B) MHz.

(8), (9) Power supply jumpers

These jumpers offer a choice of two power supplies: USB (A) and AC adapter (B). Both must be in the same position.

(10) Indicator LEDs (LED1 and LED2)

LED1 monitors the LOAD_SEL signal

LED2 is connected to Port 7, so is under program control. The built-in loader, for example, changes it from the default red that it has when the power is first applied to green when a downloaded program is executing.

(11) User connectors (CN1 and CN2)

These connectors provide access to almost all onboard MSM66Q573 microcontroller pins as well as to the ML60851C USB controller pins. The JOB60851 Starter Kit even includes the matching connectors for easily connecting these to the user application circuit under development.

3-2-2. Circuit Diagram

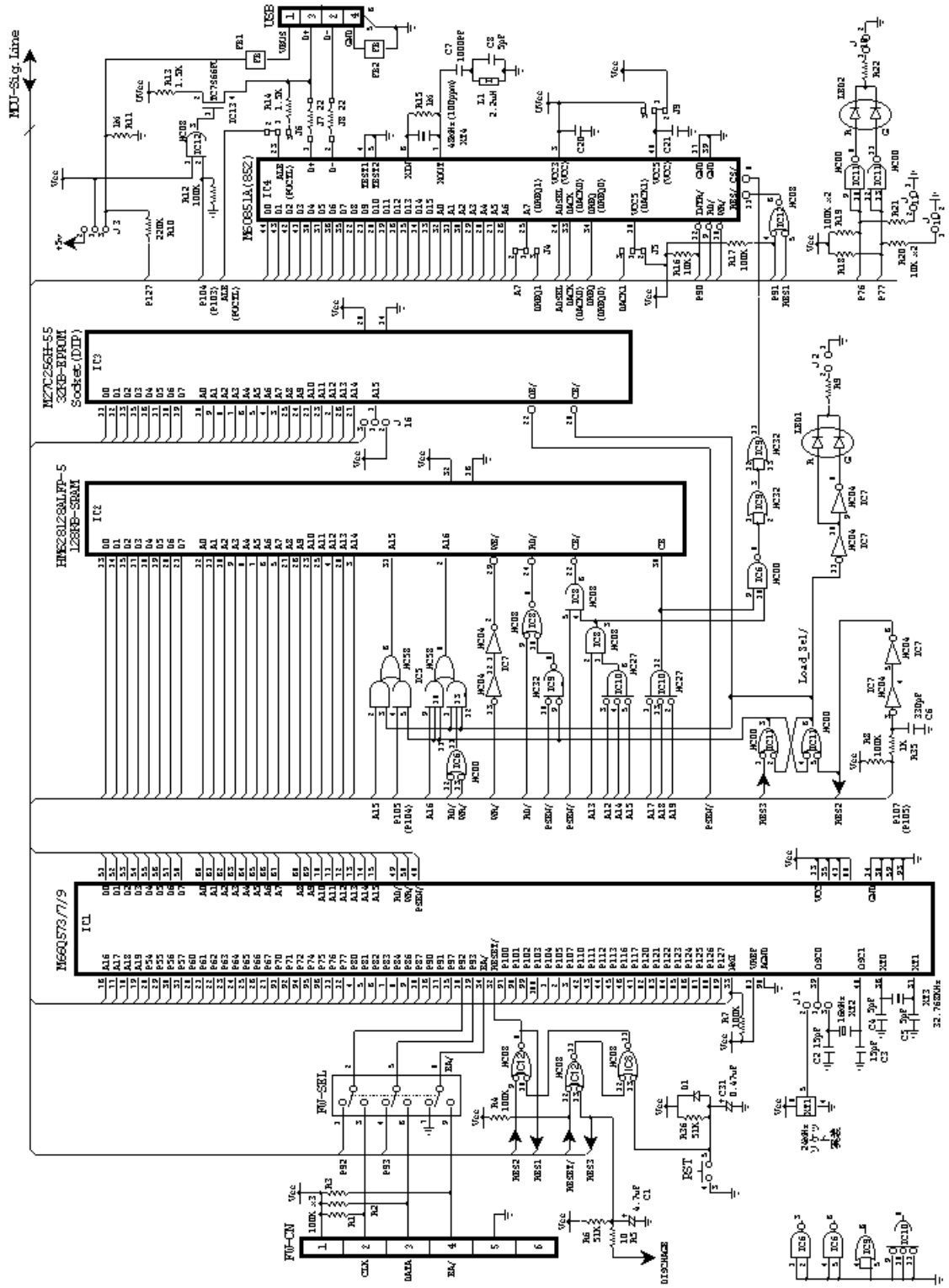

Figure 3.2.2. Circuit Diagram (1/2)

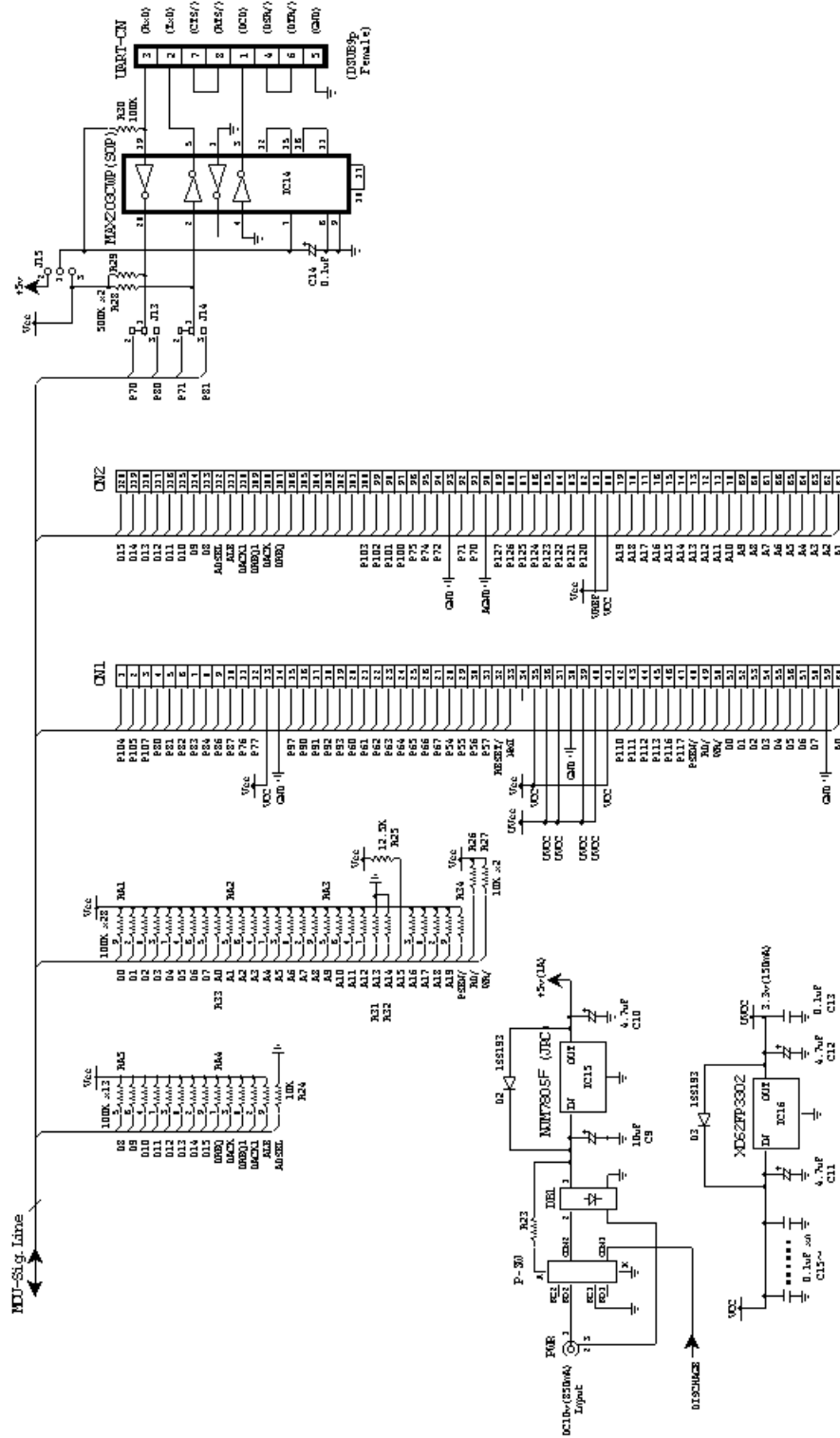

Figure 3.2.3. Circuit Diagram (2/2)

■ Note ■

An electronic version of this circuit diagram is available in the CD-ROM directory \document\job60851 as the MS Power Point document cir_j851.ppt.

3-2-3. Parts List

Tables 3.2.1 and 3.2.2 list the parts on the JOB60851 board.

Table 3.2.1. Parts List (1/2)

Item	Quantity	Reference	Part	DESCRIPTION
1	15	C13, C15, C16, C17, C18, C19, C20, C21, C22, C23, C24, C25, C26, C27, C28	0.1uF	Ceramic Capacitor
2	1	C7	1000pF	Ceramic Capacitor
3	1	C6	330pF	Ceramic Capacitor
4	3	C4, C5, C8	5pF	Ceramic Capacitor
5	2	C2, C3	15pF	Ceramic Capacitor
6	1	C31	0.47uF	Tantalum Capacitor
7	1	C9	10uF	16v Tantalum Capacitor
8	4	C1, C10, C11, C12	4.7uF	25v Tantalum Capacitor
9	1	C14	0.1uF	35v Tantalum Capacitor
10	15	R1, R2, R3, R4, R7, R8, R12, R17, R18, R19, R30, R31, R32, R33, R34	100K	Chip Resistor
11	1	R5	100	Chip Resistor
12	2	R6, R36	51K	Chip Resistor
13	3	R9, R22, R23	220	Chip Resistor
14	3	R10, R11, R15	1M	Chip Resistor
15	2	R13, R14	1.5K	Chip Resistor
16	6	R16, R20, R21, R24, R26, R27	10K	Chip Resistor
17	1	R25	12K	Chip Resistor
18	2	R28, R29	470K	Chip Resistor
19	1	R35	1K	Chip Resistor
20	5	RA1, RA2, RA3, RA4, RA5	100K x8	Chip Network Resistor
21	3	D1, D2, D3	DIODE	80v, 100mA
22	1	DB1	DIODE	200v, 1A Bridge Type
23	2	FB1, FB2	FB	Ferrite Bead Inductor
24	1	L1	2.2uH	2.2uH Inductor
25	1	IC1	M66Q573	Micro Controller
26	1	IC2	HM628128AL	128K x 8b SRAM
27	1	IC3	M27C256H	32K x 8 EPROM
28	1	IC4	M60851A	USB Device Interface
29	1	IC5	74HC58	Logic Gate
30	2	IC6, IC11	74HC00	Logic Gate
31	1	IC7	74HC04	Logic Gate
32	2	IC8, IC12	74HC08	Logic Gate
33	1	IC9	74HC32	Logic Gate
34	1	IC10	74HC27	Logic Gate
35	1	IC13	TC7S66FU	1ch Analog Switch
36	1	IC14	MAX203CWP	RS232 Xlator
37	1	IC15	NJM7805F	3-term 5v(1A) Regulator
38	1	IC16	XC62FP3302	3-term 3.3v(0.5A) Regulator
39	2	LED1, LED2	GL3ED8	LED (bright red/green)
40	1	USB	USB-212-T	USB 'B' type Receptacle
41	2	CN1, CN2	HIF3HB-60DA-2.54DSA	60pin Header Connector
42	1	FW-CN	5267-06A-X	6pin Servo Connector
43	1	UART-CN	17LE-13090-27(D3AB)	9pin RS232C Conn. Female
44	1	FW-SEL	MIS-AC-3--2N	Slide Switch
45	1	P-SW	UB-26SKP1R	Power Switch
46	1	RST	SMT1-01	Reset Switch
47	1	PWR	HEC0470-01-630	Power Input Connector
48	1	XT1	MXO-51C 24MHz	24MHz Crystal Oscillator
49	1	XT2	HC49/U-S 16MHz	48MHz Quartz Crystal
50	1	XT3	DT-38 32.768KHz	32.768KHz Quartz Crystal
51	1	XT4	HC49/U-S 48MHz +/-100ppm	48MHz +/-100ppm Quartz Crystal
52	1	PCB	QTU-11399	Printed Circuit Board

3-2-4. Memory Maps

This Section gives code and data memory maps for the various JOB60851 operation modes.

(1) Download mode

This mode maps the code memory to the EPROM and the data memory to program RAM and Flash memory. It uses the loader, a program stored in the EPROM, to download a user application program over a serial link from the development host to program RAM.

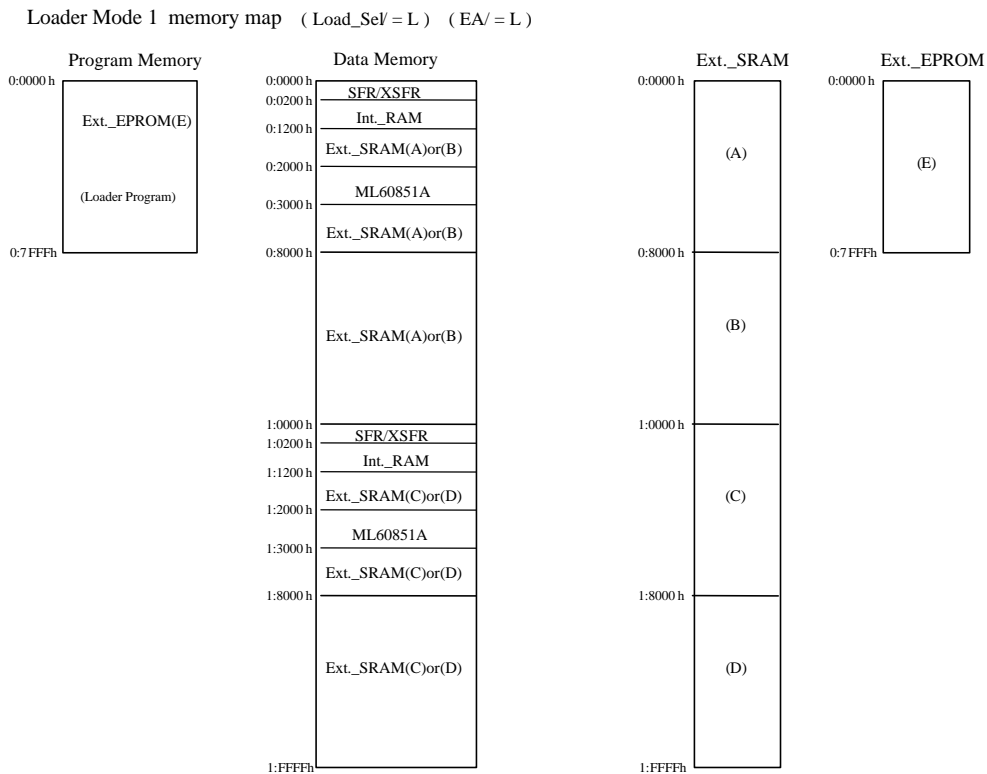

Figure 3.2.4. Memory Map for Download Mode

(2) Flash execution mode

This mode maps the code memory to the Flash memory and the data memory to work RAM. It executes the program in Flash memory. Cutting the power does not erase the program, which starts automatically when the power is next applied.

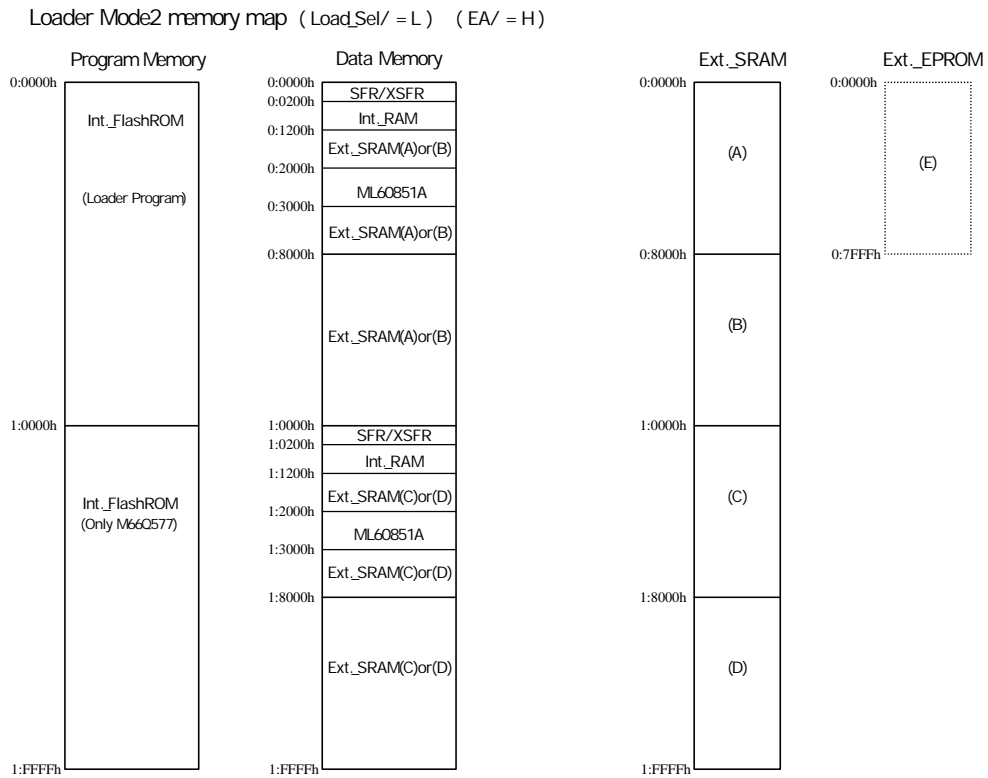

Figure 3.2.5. Memory Map for Flash Execution Mode

(3) Application mode

This mode maps the code memory to program RAM and the data memory to work RAM. It executes the program in program RAM.

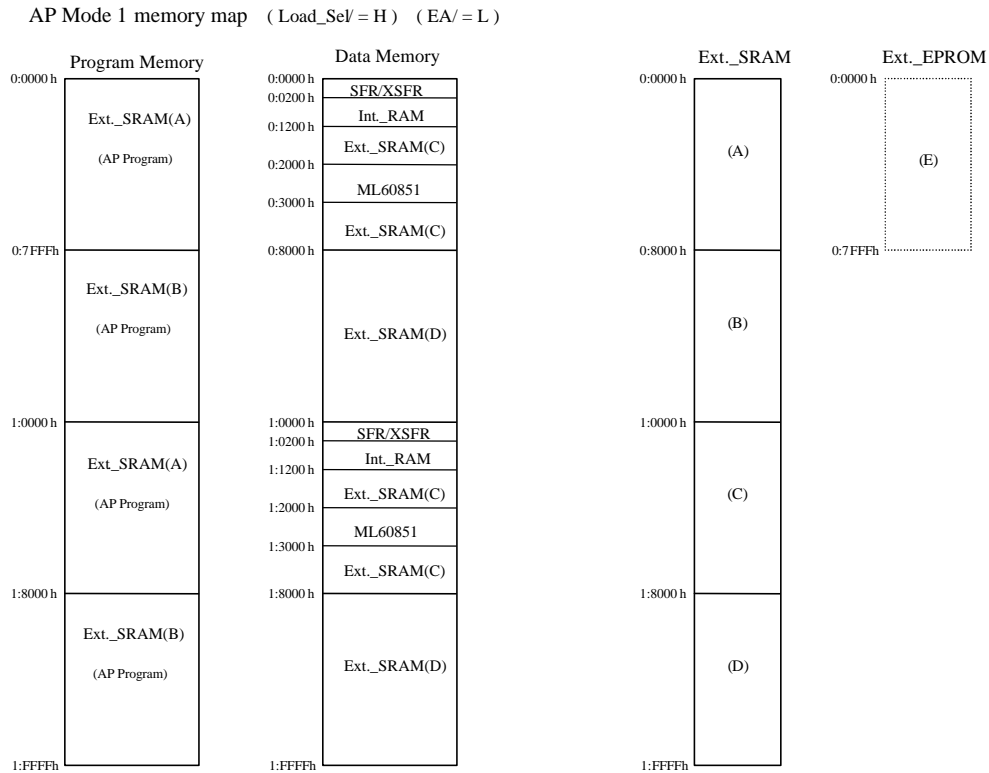

Figure 3.2.6. Memory Map for Application Mode

(4) Flash rewrite mode

This mode maps the code memory to the Flash memory and the data memory to work RAM. It executes the program in Flash memory. Cutting the power does not erase the program, which starts automatically when the power is next applied.

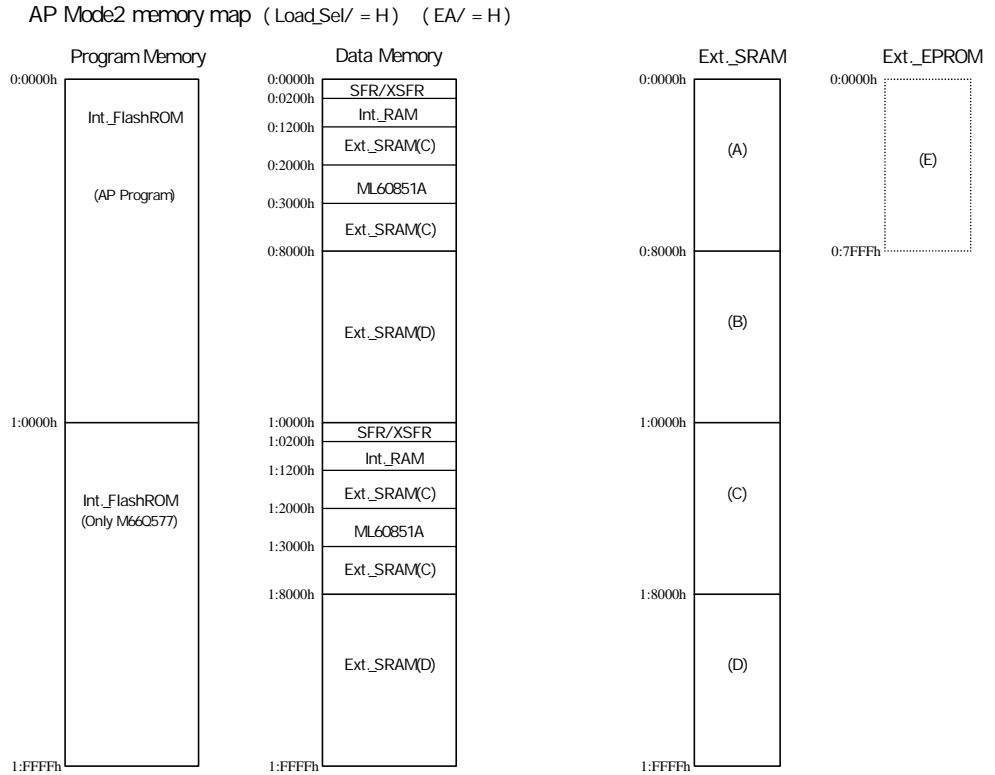

Figure 3.2.7. Memory Map for Flash Rewrite Mode

3-3. System Limitations

3-3-1. Resources Uses

The user connectors (CN1 and CN2) on the JOB60851 board make available to the user application system almost all onboard MSM66Q573 microcontroller pins and thus most microcontroller functionality.

The JOB60851 board, however, monopolizes certain microcontroller resources in running its own system, making them unavailable to the developer.

Tables 3.3.1 through 3.3.3 list the MSM66Q573 pin assignments.

Table 3.3.1. MSM66Q573 Pin Assignments (1/2)

Pin Number and Name		Connections
IC1.1	P10-4	IC12.2(R12)
IC1.2	P10-5	IC5.4
IC1.3	TM5EVT/P10-7	R8,R35
IC1.4	RXD1/P8-0	MAX203.20 (J13.3)
IC1.5	TXD1/P8-1	MAX203.2 (J14.3)
IC1.6	RXC1/P8-2	
IC1.7	TXC1/P8-3	
IC1.8	TM4OUT/P8-4	
IC1.9	PWM2OUT/P8-6	
IC1.10	PWM3OUT/P8-7	
IC1.11	PWM0OUT/P7-6	IC11.9 IC11.10
IC1.12	PWM1OUT/P7-7	IC11.12 IC11.13
IC1.13	VDD	Vcc
IC1.14	GND	Vcc
IC1.15	HLDACK/P9-7	
IC1.16	EXINT4-P9-0	IC4.12(R16)
IC1.17	EXINT5/P9-1	IC12.4(R17)
IC1.18	P9-2	FW-SEL.1,2
IC1.19	P9-3	FW-SEL.3,5
IC1.20	EXINT0/P6-0	
IC1.21	EXINT1/P6-1	
IC1.22	EXINT2/P6-2	
IC1.23	EXINT3/P6-3	
IC1.24	P6-4	
IC1.25	P6-5	
IC1.26	P6-6	
IC1.27	P6-7	
IC1.28	P5-4/CPCM0	
IC1.29	P5-5/CPCM1	
IC1.30	P5-6/TM0OUT	
IC1.31	P5-7/TM0EVT	
IC1.32	RESb	IC12.8 IC12.12
IC1.33	NM1	R7
IC1.34	EAb	FW-SEL.8
IC1.35	VDD	Vcc
IC1.36	XT0	XT3
IC1.37	XT1b	XT3
IC1.38	GND	Vcc
IC1.39	OSC0	J1
IC1.40	OSC1b	XT2

Table 3.3.1. MSM66Q573 Pin Assignments (2/2)

IC1.41	VDD	Vcc			
IC1.42	P11-0/WAIT				
IC1.43	P11-1/HOLD				
IC1.44	P11-2/CLKOUT				
IC1.45	P11-3/XTOUT				
IC1.46	P11-6/TM9OUT				
IC1.47	P11-7/TM9EVT				
IC1.48	P3-1/PSENB	IC3.22	IC8.5	IC9.10	R34
IC1.49	P3-2/RDb	IC6.12	IC8.9		R26
IC1.50	P3-3/WRb	IC6.13	IC7.13		R27
IC1.51	P0-0/D0	IC2.13	IC3.11	IC4.44	RA1.9
IC1.52	P0-1/D1	IC2.14	IC3.12	IC4.43	RA1.2
IC1.53	P0-2/D2	IC2.15	IC3.13	IC4.42	RA1.8
IC1.54	P0-3/D3	IC2.17	IC3.15	IC4.41	RA1.3
IC1.55	P0-4/D4	IC2.18	IC3.16	IC4.38	RA1.7
IC1.56	P0-5/D5	IC2.19	IC3.17	IC4.37	RA1.4
IC1.57	P0-6/D6	IC2.20	IC3.18	IC4.36	RA1.6
IC1.58	P0-7/D7	IC2.21	IC3.19	IC4.35	RA1.5
IC1.59	GND	Vcc			
IC1.60	P4-0/A0	IC2.12	IC3.10	IC4.32	R33
IC1.61	P4-1/A1	IC2.11	IC3.9	IC4.31	RA2.5
IC1.62	P4-2/A2	IC2.10	IC3.8	IC4.30	RA2.6
IC1.63	P4-3/A3	IC2.9	IC3.7	IC4.29	RA2.4
IC1.64	P4-4/A4	IC2.8	IC3.6	IC4.28	RA2.7
IC1.65	P4-5/A5	IC2.7	IC3.5	IC4.27	RA2.3
IC1.66	P4-6/A6	IC2.6	IC3.4	IC4.26	RA2.8
IC1.67	P4-7/A7	IC2.5	IC3.3	IC4.25.(J4.2)	RA2.2
IC1.68	P1-0/A8	IC2.27	IC3.25		RA2.9
IC1.69	P1-1/A9	IC2.26	IC3.24		RA3.5
IC1.70	P1-2/A10	IC2.23	IC3.21		RA3.6
IC1.71	P1-3/A11	IC2.25	IC3.23		RA3.4
IC1.72	P1-4/A12	IC2.4	IC3.2	IC10.3	RA3.7
IC1.73	P1-5/A13	IC2.28	IC3.26	IC8.2	R31
IC1.74	P1-6/A14	IC2.3	IC3.27	IC10.4	R32
IC1.75	P1-7/A15		IC3.1	IC52	R25
IC1.76	A16/P2-0	IC5.9			RA3.3
IC1.77	A17/P2-1	IC10.1			RA3.8
IC1.78	A18/P2-2	IC10.13			RA3.2
IC1.79	A19/P2-3	IC10.2			RA3.9
IC1.80	VDD	Vcc			
IC1.81	VREF	Vcc			
IC1.82	A10/P12-0				
IC1.83	A11/P12-1				
IC1.84	A12/P12-2				
IC1.85	A13/P12-3				
IC1.86	A14/P12-4				
IC1.87	A15/P12-5				
IC1.88	A16/P12-6				
IC1.89	A17/P12-7				R10
IC1.90	AGND	GND			
IC1.91	RXD0/P7-0	MAX203.20 (J13.2)			
IC1.92	TXD0/P7-1	MAX203.2 (J14.2)			
IC1.93	GND	Vcc			
IC1.94	RXC0/P7-2				
IC1.95	TM3OUT/P7-4				
IC1.96	TM3EVT/P7-5				
IC1.97	SIOCK3/P10-0				
IC1.98	SIOI3/P10-1				
IC1.99	SIOO3/P10-2				
IC1.100	P10-3				

4. Software Development

Section 4-1. "USB Basics" provides an overview of the Universal Serial Bus (USB) specifications as well as URLs for obtaining detailed specifications.

Section 4-2. "Sample USB Firmware" provides a functional overview of the sample device firmware shipped with the JOB60851 Starter Kit and procedures for modifying the source code and evaluating the result.

Section 4-3. "USB Bits and Pieces" covers device controller specifications, device controller operational overview, notes to device developers. etc.

Sections 4-4. "Port 7 LED2 Control" and 4.5 "Standard I/O over Serial Link" give procedures for modifying the sample source code for simple debugging with the JOB60851 board. They cover both procedures controlling the onboard LED2 and those using standard I/O library functions (printf(), scanf(), etc.) over the serial link to a terminal emulator.

4-1. USB Basics

4-1-1. Bus Topology, Addresses, and Hot Plugging

The Universal Serial Bus (USB) features a tiered star topology with a single host controller (a.k.a. root or Tier 0 hub) at the top of a device tree consisting of functions branching off hubs(a.k.a. repeaters).

A tree has up to 127 such devices (hubs and functions) with addresses 1 to 127. The address 0 is reserved for use as the default control address that USB devices use when they are first powered on or reset. Requests from the host controller use this default address to determine the structure of this new device and assign it an address. This highly flexible arrangement holds the key to hot plugging (a.k.a. dynamic insertion and removal).

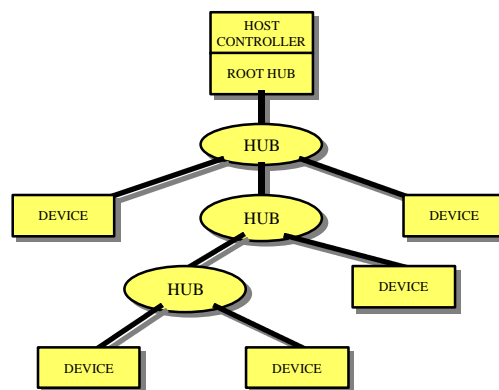

Figure 4.1.1. Bus Topology

The tree can chain hubs to produce up to five tiers. Cables between hubs or between a hub and a device can be up to five meters long. To prevent the formation of illegal loopback connections at hubs, the downstream ports on the root and other hubs use a connector (Series A) mechanically different from those on the upstream ports on devices (Series B).

The JOB60851 board is for developing devices, not hubs, so features a Series B connector for connection to the Series A one on the root or other hub.

4-1-2. Specification Documents

USB specifications have been established by the USB Implementers Forum. These and other materials are available on the World Wide Web at the following URLs.

Forum top page	http://www.usb.org/developers/
Developers section	http://www.usb.org/developers/
Developer documentation	http://www.usb.org/developers/docs.html
Device classes	http://www.usb.org/developers/devclass.html
Compliance testing	http://www.usb.org/developers/complian.html

The USB Implementers Forum augments the core specifications, the document specifying characteristics shared by all USB devices, with separate Universal Serial Bus Device Class Specifications for specific device types.

4-1-3. Core Specifications

This document covers common characteristics of host controllers, hubs, devices, and transmission pathways. Specific areas include an overview of USB communications, functionality, and bus drivers; physical and electrical specifications for connectors, transmission pathways, and other components; and the standard command-response device requests that all USB devices must support. The current version number is 1.1.¹

■ Note ■

Note: Version 1.1 superseded version 1.0 in October 1998. The older version is still available on the World Wide Web. Apart from such additions as InterruptOut transfers, most changes involve removing ambiguities in the older version. The electrical specifications in Chapter 7 now provide more detail. The protocol layer specifications in Chapter 8 add descriptions of STALL operation for the default control pipe and of the Data stage of control transfers. The device framework specifications in Chapter 9 add descriptions of state processing for request errors. The hub specifications in Chapter 11 have been completely rewritten.

Chapter 1	Introduction	Objectives and target audience for USB specifications
Chapter 2	Terms and Abbreviations	Definitions of key terms used
Chapter 3	Background	Design goals and requirements addressed
Chapter 4	Architectural Overview	Overview of USB architecture and key concepts
Chapter 8	Protocol Layer	Packet definitions and detailed descriptions of transaction formats for error detection and recovery, etc.
Chapter 9	USB Device Framework	Detailed descriptions of device states, device requests,

¹ Version 1.1 superseded version 1.0 in October 1998. The older version is still available on the World Wide Web. Apart from such additions as InterruptOut transfers, most changes involve removing ambiguities in the older version. The electrical specifications in Chapter 7 now provide more detail. The protocol layer specifications in Chapter 8 add descriptions of STALL operation for the default control pipe and of the Data stage of control transfers. The device framework specifications in Chapter 9 add descriptions of state processing for request errors. The hub specifications in Chapter 11 have been completely rewritten.

Chapter 4 Software Development

		standard device requests, and standard device descriptors
Chapter 10	USB Host: Hardware and Software	Functions and operation of host hardware and software
Chapter 11	Hub Specification	Hub port operation, requests, and descriptors

Chapter 4 provides a firm grounding in the USB core specifications. All developers of USB equipment must study Chapter 5 very carefully. Hardware developers must read Chapter 7; firmware developers, Chapters 8 and 9. Firmware developers must pay particular attention to the timing specifications in Chapter 7.

What follows are key points from the core specifications. For complete details, refer to the specifications available from the USB Implementers Forum web site.

4-1-4. Data Flow Types

The USB specifications define four data flow types with the following characteristics. Flexibly combining these four data flow types provides solutions to the communications needs of a wide variety of applications.

Table 4.1.2. USB Data Flow Types

Control	Communication of commands and responses for device configuration and pipe control
Bulk	Transfer of relatively large, bursty data volumes with wide dynamic latitude in transmission constraints
Interrupt	Transfer of small data volumes within time limits based on human-perceptible echo or feedback response characteristics
Isochronous	Transfer using prenegotiated USB bandwidth with a prenegotiated delivery latency--audio data, for example--with no procedure for retransmitting data

4-1-5. Bus Transactions

Data transfers consist of bus transactions, exchanges of basic packets between the host and a specific device. The example below shows two such transactions.

The first data request (IN) from the host arrives when the device has no data for delivery, so the latter returns a NAK handshake, completing the transaction. The NAK indicates two things: that the device has no data ready and that the host should resend the request later.

The second data request (IN), in contrast, causes the device to deliver the data (DATA0) that it has ready. The host acknowledges successful receipt of this data with an ACK, completing the transaction.

Transactions require certain bit time order response, so are implemented in hardware.

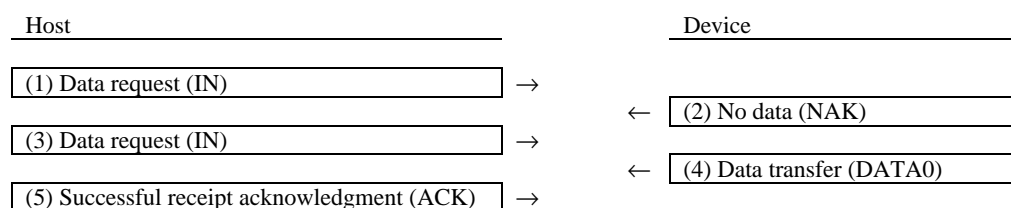

Figure 4.1.2. Two USB Transactions

All bus transactions begin with a token packet from the host. Devices never initiate data transfers on their own.

The host controller is in charge of scheduling all traffic on the bus. It schedules the appropriate transactions for the four data flow types at 1-ms intervals, which the USB documentation calls frames.

Token packet types include data request (IN), data transfer notification (OUT), and command transfer notification (SETUP).

4-1-6. Packets

A packet is a continuous bit stream starting with the synchronization pattern and flowing in one direction.

Table 4.1.3. lists the USB packet types.

PID Type	PID Name	Transmitter	Description
Token	OUT	Host	Data transfer notification
	IN	Host	Data request
	SOF	Host	Start of frame
	SETUP	Host	Data transfer notification for control pipe
Data	DATA0	Host/Device	Data packet PID even
	DATA1	Host/Device	Data packet PID odd
Handshake	ACK	Host/Device	Receiver accepts error-free packet
	NAK	Device	Transmitter cannot send data Receiver cannot accept data
	STALL	Device	Control pipe request not supported Endpoint halted
Special	PRE	Host	Preamble enabling downstream bus traffic to low-speed devices

4-1-7. Endpoints

The USB provides separate logical communication flows, called pipes, between the host and a USB function. The function end of a pipe is called the endpoint. This endpoint must provide buffer space (FIFO) capable of holding at least one data packet (a.k.a. the maximum payload size).

Endpoints and pipes are characterized, at creation, by the direction (from or to host) and by the data flow type (control, bulk, interrupt, or isochronous). There are provisions for up to 16 pipes in each direction, for a total of 32 endpoints per function. The token packet that the host transmits to initiate a transaction specifies the endpoint buffer with the endpoint address made up of the device address and the endpoint number.

USB device controller capacity is expressed by the number of endpoints it has and such endpoint specifications as supported data flow types and endpoint buffer sizes. Examining these endpoint specifications thus reveals whether the USB device controller is suitable for the intended application.

4-1-8. Data Rates

The USB supports two data rates: 12 Mb/s and 1.5 Mb/s. Table 4.1.4 lists the maximum payload sizes for each combination of data flow type and data rate.

Table 4.1.4. Maximum Payload Sizes

Transfer Types	MAX Payload Size	
	12 Mbps	1.5 Mbps
Control	8/16/32/64	8
Isochronous	1023 or less	N/A
Interrupt	64 or less	8 or less
Bulk	8/16/32/64	N/A

A hub determines the data rates supported by an attached function by examining the latter's Non Return to Zero Invert (NRZI) data signal lines (D+ and D-). A device supporting the high speed pulls up the D+ line to the 3.3-volt power supply voltage with a 1.5-k Ω resistor; one supporting the low speed does the same with the D- line.

The ML60851C USB controller operates exclusively at 12 Mb/s, so the JOB60851 board includes only the D+ pull-up resistor.

4-1-9. Device Class Specifications

The Universal Serial Bus Device Class Specifications complement the core specifications by further standardizing USB devices for major interfaces and specific applications devices using those interfaces.

Some interface specifications standardize the communications pathways that the USB hardware provides for a specific purpose--the exchange of isochronous audio or image data, for example. Others standardize USB specifications for devices combining multiple interfaces.

Table 4.1.5 lists some of the USB Device Class Specifications currently available. For further details, refer to the following URL.

Table 4.1.5. USB Device Class Specifications

Device Class	Applicable Equipment
Human interface devices (HIDs)	Mice, keyboards, joysticks, etc.
Printers	Printers
Audio devices	Speakers, microphones, etc.
Communications devices	Modems, ISDN terminal adapters, etc.
Mass storage devices	Fl oppy disk drives, SCSI equipment, ATAPI equipment, etc.
Image devices	Digital cameras, scanners, low-rate video, etc.

There is also a standard for downloading programs to devices.

<http://www.usb.org/developers/devclass.html>

4-1-10. Device Requests

Device requests represent commands from the host to USB functions using control transfers. The USB function parses the request, performs the necessary action, and returns the appropriate response.

There are three types of device requests.

Table 4.1.6. Device Request Types

Standard	Requests that all USB devices must support because they hold the key to hot plugging (a.k.a. dynamic insertion and removal)
Class-specific	Requests required by the USB Device Class Specifications for the general application
Vendor-specific	Requests implemented by the vendor for accessing functionality particular to the USB device

A control transfer starts with a SETUP token packet followed by an 8-byte data packet containing the following fields. Note that the meaning of the wValue and wIndex fields depends on the request type.

Table 4.1.7. Control Transfer Data Packet

<i>bmRequestType</i>	1byte	Transfer direction, request type, and endpoint address
<i>bRequest</i>	1byte	Request number
<i>wValue</i>	2byte	Value (meaning depends on the request type)
<i>wIndex</i>	2byte	Index or offset (which depends on the request type)
<i>wLength</i>	2byte	Number of bytes transferred during the Data stage

A control transfer consists of up to three stages.

1. Setup stage: The data packet following the SETUP token packet is an 8-byte command from the host to the device. The device parses the command and, as necessary, prepares to send or receive data.
2. Data stage: The pipe transfers the specified data in the direction specified by the command. Note that commands that do not involve data transfer skip this stage.
3. Status stage: The host initiates a transaction, in the direction opposite the immediately preceding data transfer, for reporting command success or failure from the device to the host.

4-1-11. Standard Device Requests

The standard device requests are common ones to all USB devices. Most important are those that support hot plugging (a.k.a. dynamic insertion and removal). Detailed descriptions are in Section 9.-4 of the USB version 1.1 specifications.

Table 4.1.8. Standard Device Requests

No.	Request Name	Description
0	GET_STATUS	Return status for specified recipient
1	CLEAR_FEATURE	Clear or disable a specific feature
3	SET_FEATURE	Set or enable a specific feature
5	SET_ADDRESS	Set device address for all future device accesses
6	GET_DESCRIPTOR	Return the specified descriptor, if it exists

7	SET_DESCRIPTOR	Update or add a descriptor
8	GET_CONFIGURATION	Return the current device configuration value
9	SET_CONFIGURATION	Set the device configuration value
10	GET_INTERFACE	Return the selected alternate setting for the specified interface
11	SET_INTERFACE	Set the alternate setting for the specified interface
12	SYNCH_FRAME	Set and report an endpoint's synchronization frame

4-1-12. Device Descriptors

When a USB device first connects to the bus, it reports its attributes to the host with a device descriptor. Figure 4.1.3 illustrates the hierarchical structure of this data structure with the device descriptor for a bidirectional printer.

Endpoint descriptors give the physical capabilities of the endpoints already discussed in Section 4.1.7 above.

Groups of endpoint descriptors form logical communications functions called interfaces. These interfaces support alternate settings for changing the interface and thus device characteristics. Note that these interfaces are mutually exclusive in that only one can be in use at any given time.

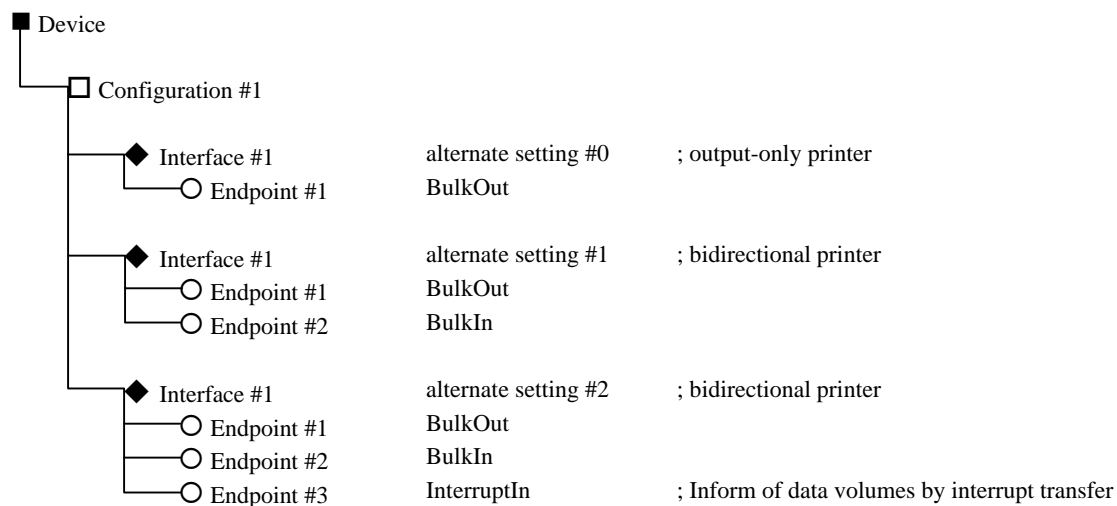

Figure 4.1.3. Device Descriptor for Bidirectional Printer

Higher up the hierarchy are the configuration and device layers. The same device can have multiple configurations--drawing its power from the bus or its own local power supply, for example. It can even start as a power-saving device and later switch to a high-consumption one.

The following are brief listings of descriptor contents. For detailed descriptions, refer to Section 9.4 of the USB version 1.1 specifications.

(1) Device descriptor

- USB Specification release number in binary coded decimal
- Device class code
- Device subclass code
- Protocol code
- Maximum packet size for endpoint 0 (EP0)
- Vendor and product IDs

Device release number in binary coded decimal

Index numbers for string descriptors describing manufacturer, product, and device serial number

Number of possible configurations

(2) Configuration descriptor

Total size of this descriptor in bytes

Number of interfaces supported by this configuration

Unique number for this configuration

Index number for string descriptor describing this configuration

Configuration power supply attributes

Remote wake-up support

Maximum power consumption when using bus power supply

(3) Interface descriptor

Total size of this descriptor in bytes

Number of interface

Number of endpoints used by this interface

Class code

Subclass code

Protocol code

Index number for string descriptor describing this interface

(4) Endpoint descriptor Total size of this descriptor in bytes

Data flow direction (IN or OUT)

Data flow type (control, bulk, interrupt, or isochronous)

Maximum packet size (payload) for this endpoint

Interval for polling this endpoint for interrupt transfers

(5) String descriptor

Total size of this descriptor in bytes

Unicode encoded string

4-2. Sample USB Firmware

The JOB60851 Starter Kit includes the complete source code for use as the starting point for the user USB firmware. To see the effects of user modifications on behavior, edit the source code, compile it, link it into an executable .HEX file, and then download and execute this file with the procedure in Section 2.3 "Running User Programs."

This Section outlines the entire cycle.

4-2-1. Setup

Copy the file M851xxxx.exe from the \Usb_firm directory on the CD-ROM to a work directory--c:\work in our example. This file is a self-expanding archive that automatically extracts the sample source code to the appropriate subdirectories shown in Table 4.2.1.

After executing this file in the work directory, open Readme.txt. This text file lists the contents of the archive. Be sure to read the disclaimer section about rights to the source code.

Table 4.2.1. Sample USB Firmware

\Work		Compiler work directory
	\Include	Include files
	\Src	Source files (shared files)
	\66573	cc665s source code for 16-bit MSM66573 microcontrollers
	\Arm	ARM-SDT source code for 32-bit ARM microcontrollers
	\Err	cc665s assembler error output directory
	\Lst	cc665s assembler listing file output directory
	\Debug	ARM-SDT debugging code output directory
	\Release	ARM-SDT release code output directory
	\traffic	Sample data for use with the Computer Access Technology Corporation (CATC) USB evaluation system.

4-2-2. Sample Firmware Specifications

The source code on the CD-ROM produces the sample USB firmware shipped in the MSM66Q573 Flash memory. This firmware is perfectly general code that provides the standard device request support and standard descriptors required by the USB core specifications. It does not assume any particular application. It supports the three data flow types (control, bulk, and interrupt) offered by ML60851 USB controllers.

For the detailed specifications of this sample USB firmware, refer to the text file M852.txt accompanying it in the work directory. Note that the source code supports both ML60851 and ML60852 USB controllers and that M852.txt covers the 32-bit ARM microcontroller as well as these two devices. Read only the sections applicable to the ML60851C USB controller and the 16-bit MSM66Q573 microcontroller.

■ Note ■

As of August 1999, operation has been confirmed only for the MSM66Q573 plus ML60851C combination. The ARM code is a preliminary version that does not compile.

4-2-3. Sample USB Host Software

The CD-ROM directory \package\host contains the following USB host software for testing such things as bulk data flow. A brief overview of operation appears in Section 2.

Readme.txt	Software description, usage notes, etc.
Rwbulk.exe	Test application
Bulkusb.sys	WDM-USB driver
Bulkusb.inf	WDM-USB driver installer information file

This USB host software adopts the following layered approach. For a detailed description, refer to the accompanying text file Readme.txt.

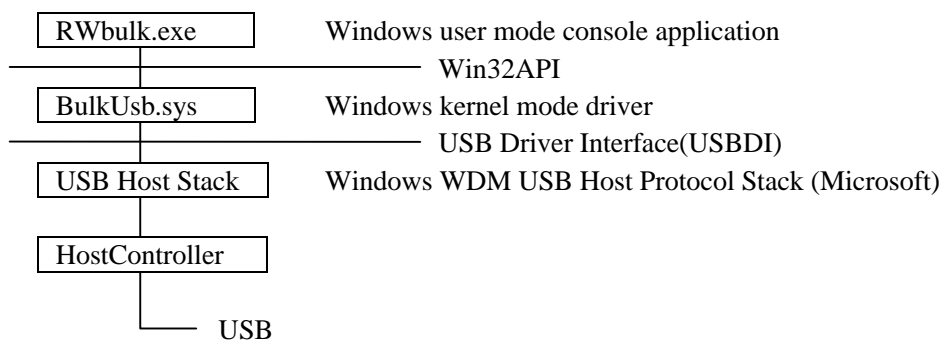

■ Note ■

This sample host software runs only under Windows 98. It is only for provisional use by firmware developers pending the completion of proper host drivers and applications. It is not robust enough for heavy use. In fact, continued use risks operating system instability and even hang-ups. Note that we are unable to respond personally to technical queries with regard to this software.

4-2-4. Compiling and Executing Sample USB Firmware

Compiling the sample USB firmware requires the cc665s compiler installed in Section 2.1.2. Double-check the environment variables from that Section.

The work directory containing the sample USB firmware--c:\work in our example--contains make files for two popular make utilities (not included in the JOB60851 Starter Kit): Makefile.nmk for use with nmake from Microsoft and Makefile.bor for use with maker from Inprise (formerly Borland). Rename or copy the appropriate one to makefile. Also available is the batch file cl665s.bat for users without either of these make implementations. Successful compilation produces the file USB.HEX in the work directory. Check the link map file USB.M66 in the same directory for error messages from the linker.

To test USB.HEX, download it to the JOB60851 board and execute it there with the procedure in Section 2-3. "Running User Programs." Use Rwbulk.exe and the procedure in Section 2-2-2. "Running Flash Memory Program" to test bulk data flow.

4-2-5. Confirming USB Compliance with Usbcheck.exe

The USB Implementers Forum web site provides Usbcomp.exe, a self-extracting archive containing Usbcheck.exe, host software for checking support for USB standard device requests.

<http://www.usb.org/developers/complian.html>

■ **Note** ■

As of August 1999, this software is at version 3.2 and requires Windows 98 Second Edition. Users of older Windows 98 versions should download version 2.9 instead.

Once this software has been successfully installed, use the following test procedure to reconfirm the compliance of the program shipped in the MSM66Q573 Flash memory.

■ **Note** ■

The procedure for running the program itself is in Section 2.2 "Running Default Program."

1. Detach all USB devices connected to the personal computer.
2. Double-click the USB Check icon to start the application.
3. Comply with the message box asking you to connect USB devices by plugging in the cable to the JOB60851 board and applying power to the latter (#2 in Figure 2.1.1).
4. Wait while Windows 98 automatically installs the drivers for the JOB60851 board.
5. When the USB Compliance Tool dialog box appears, click the Full test button at the bottom.
6. When the USB Chapter 9 tests dialog box appears, click the Start automatic testing button at the bottom.
7. If the tests run successfully to completion and the Full test results dialog box with the Run other tests button appears, click the OK button to return to the USB Chapter 9 tests dialog box.
8. Click the Cancel automated testing button to display the following information in the Device info section in the middle of the left side of the dialog box that appears.

If the display matches the information above, the tests are complete.

Usbcheck.exe checks compliance by issuing each USB standard device request. It should, therefore, always be the first test after downloading a modified version of the sample USB firmware to the JOB60851 board.

■ **Note** ■

If Usbcheck.exe aborts in the early stages of dynamic insertion, go back and double-check the most recent source code modifications.

4-2-6. Creating USB Mouse Demo

The next stage involves modifying the sample program slightly so that the JOB60851 board emulates a USB mouse. Use the following steps to modify the source code and then recompile.

(1) Modifying source code

The file Include\Class.h under the work directory specifies as its default the device class BULK_IN_OUT_AND_INT. Comment out that #define and uncomment the HID_MOUSE_ONLY one.

```
/*      1. Specify device class      */
      #define      HID_MOUSE_ONLY      /* ← Enable this one */
/*      #define      BULK_AND_HID_MOUSE      */
/*      #define      HID_MOUSE_AND_BULK      */
/*      #define      BULK_IN_OUT_AND_INT      /* ←Disable this default */
/*      #define      COMPLEX_ALTERNATE      */
/*      #define      PRINTER      */
/*      #define      ISO_TEST      */
```

(2) Compiling

The supplied make files and compiler do not check for dependencies on files in the include directory, so first clean the .HEX and .OBJ files from the work directory and then run the make utility.

```
n make clean <Enter> or maker clean <Enter>
nmake <Enter> or maker <Enter>
```

Successful compilation produces the file USB.HEX in the work directory. Check the link map file USB.M66 in the same directory for error messages from the linker.

(3) Setting up mouse demo

The sample mouse program emulates a USB mouse in response to commands received over a serial link to the JOB60851 board. It therefore requires connecting both the USB cable and, using the procedure in subsections 1-3 in Section 2.3 "Running User Programs," the serial cable.

(4) Downloading program and installing mouse driver

To test USB.HEX, download it to the JOB60851 board and execute it there with the procedure in Section 2.3 "Running User Programs."

When the JOB60851 board connects the emulated USB mouse to the personal computer, Windows 98 automatically launches its driver wizard, so install the HID mouse driver from the CD-ROM.

■ **Note** ■

The Windows 98 CD-ROM is not necessary if the OEM release has copied the installation image from the CD-ROM to the directory c:\Windows\Option. If so, specify that directory instead of the CD-ROM.

(5) Operate mouse with terminal emulator

After reading the messages on the terminal emulator screen, enter HELP at the command prompt to display the commands available. Try RIGHT, LEFT, UP, and DOWN, for example.

Another way to test the emulated USB mouse is with HIDview, the HID class device portion of Usbcheck.exe.

4-2-7. Modifying Application Layer

This section gives a hints for modifying the application layer. Note that, in practice, such modifications require careful study of the USB Specifications, M852.txt, and the source code.

A USB device controller basically uses interrupt-driven communications control. The following API functions provide the application layer with access to such functionality as initialization, specifying callback function, and initiating data flow.

usb_init()	Initialize USB control variables
usb_set_callback()	Specify notification function for bulk transfer compl
usb_tx_start()	Specify transmit data buffer and start
usb_rx_start()	Specify receive data buffer and start
usb_int_enable()	Enable packet ready interrupt
usb_int_disable()	Disable packet ready interrupt
usb_remote_wakeup()	Transmit remote wake-up signal
usb_cfg_status()	Retrieve information from current configuration descriptor
usb_alt_status()	Retrieve current alternate setting

The sample firmware provides everything needed to evaluate hot plugging (a.k.a. dynamic insertion and removal) using control transfers and standard device requests.

The sample application layer provides loopback from endpoint 1 (EP1) to endpoint 2 (EP2). Modifying the source code in the file main.c permits the simple use of bulk transfers from upstream applications.

The source code below gives skeletons for two simple application layers consisting of only BulkOut (receive) or BulkIn (transmit) operations, respectively. Modify the source code, recompile it, download it to the JOB60851 board, and run the program.

For further details on the API functions, refer to the file M852.txt.

Receive Only Skeleton

```
char buf_rx[BUF_SIZE];

void bulk_rx(uchar *buf, uint size)
{
    /* Called after receiving each packet, this function manages buffer overflow for the application
    layer. */
    if(Receive buffer threatens to overflow){
        usb_rx_start(buf_rx, EP_RX); /* Reinitialize pointer to start of buffer */
    }
}

void main(void)
{
    /* Initialize microcontroller and peripherals, etc. */
    :
    usb_init(); /* Initialize USB control variables */
    usb_set_callback(EP_RX, rx_callback); /* Specify receive callback function */
    usb_rx_start(buf_rx, EP_RX); /* Specify receive data buffer and start */
    :
    while(1){
        /* Main loop */;
    }
}
```

Transmit Only Skeleton

```
char buf_tx[BUF_SIZE];

void bulk_tx(uchar *buf, uint size)
{
    /* This function is called after transmitting each packet. */
    usb_tx_start(buf_tx, EP_TX); /* Reinitialize pointer to start of buffer */
}

void main(void)
{
    /* Initialize microcontroller and peripherals, etc. */
    :
    usb_init(); /* Initialize USB control variables */
    usb_set_callback(EP_TX, bulk_tx); /* Specify transmit callback function */
    usb_tx_start(buf_tx, EP_TX); /* Specify transmit data buffer and start */
    :
    while(1){
        /* Main loop */;
    }
}
```

4-2-8. Simple Debugging

The JOB60851 board allows simple debugging over the serial link to a terminal emulator with printf(), scanf(), and other C standard I/O library functions. Also available for use in debugging is LED2, which is connected to Port 7 and thus under program control. For further details, see Sections 4.4 "Port 7 LED2 Control" and 4.5 "Standard I/O over Serial Link."

4-2-9. Evaluating USB Equipment

The USB Implementers Forum has published USB interface compliance guidelines. The following URL provides access to guidelines and peripheral check lists for power consumption, UBS device framework (using Usbcheck.exe described above), and equipment configurations for testing interconnectivity.

<http://www.usb.org/developers/complian.html>

Every three or four months, the USB Implementers Forum conducts a compliance workshop for testing interconnectivity. Passing these tests earns the devices the right to use the USB logo.

4-3. USB Bits and Pieces

4-3-1. Device Controller Specifications

Table 4.3.1 summarizes the ML60851C specifications. For detailed device specifications, see the data sheet (ML60851c.pdf).

Table 4.3.1. ML60851C Specifications

Data transfer speed	Full speed (12 Mb/s) only			
Endpoint specifications	Data flow type	Endpoint	Direction	Buffer size
	Control	EP0	In	8bytes
			Out	8bytes
	Bulk	EP1	In and out	64 bytes × 2
		EP2	In and out	64bytes
	Interrupt	EP3	In	8bytes
Isochronous	-	-	-	
DMA	8/16-bit DMA request function (Endpoint 1: DMA request and acknowledge)			
Power supply	Vcc3=3.0 to 3.6V, Vcc5=3.0 to 5.5V Interface to 5-volt microcontroller with local power supply (Vcc5)			
Package	44-pin QFP or TQFP			

4-3-2. Overview of ML60851C Operation

Figure 4.3.1 is a block diagram for ML60851C internals. The basic structure and operation are both simple. The receiver digitizes the inputs from the USB differential (D+/D-) data bus for the protocol engine. The phase-locked loop (DPLL) synchronizes the protocol engine with the bus clock.

The protocol engine executes the transactions. It analyzes the time-multiplexed packets over the USB bus looking for transactions including its assigned address. If it finds one, it analyzes the request from the host to the corresponding endpoint and then accesses the appropriate buffer for receiving from or transmitting to the USB bus.

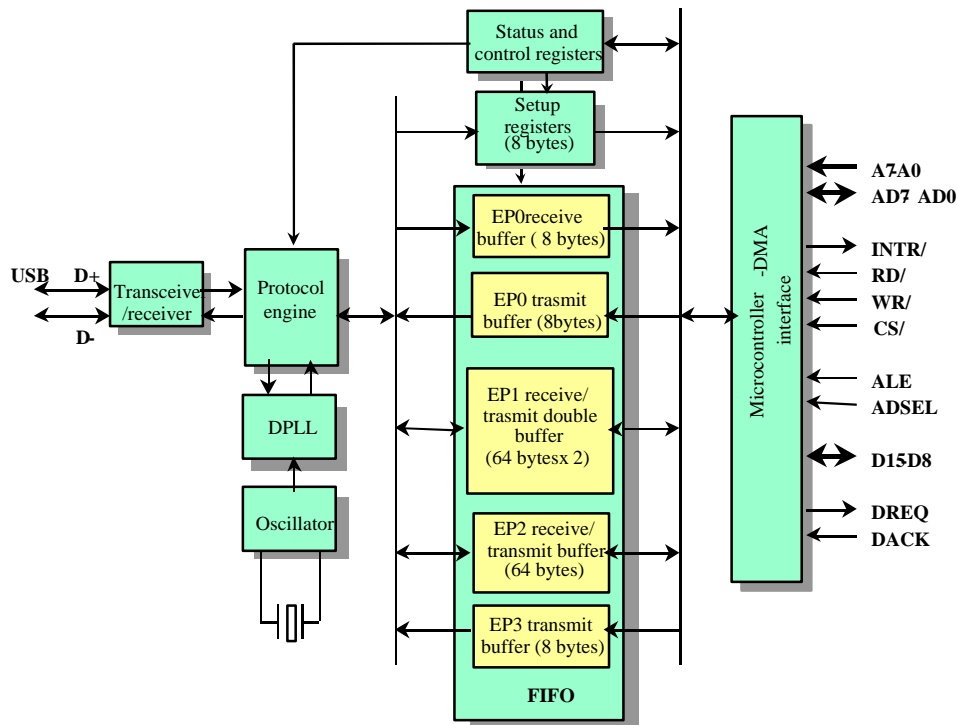

Figure 4.3.1. ML60851C Block Diagram

Protocol engine operation for a control transfer setup transaction differs from that for all other transactions.

Setup transactions always write the eight bytes in the associated data packet to the setup registers. If this data is received successfully, the protocol engine sends an ACK back to the host. It also sends a setup interrupt to the control microcontroller to request register readout.

Data receive transactions write the data from the USB bus to the specified endpoint's receive buffer if there is room. If this data is received successfully, the protocol engine sends an ACK back to the host. It also sends a data received interrupt for the command to the control microcontroller. If there is no room in the receive buffer or there is an error, the protocol engine sends a NAK back to the host.

Data transmit transactions send a data packet from the specified endpoint's transmit buffer to the USB bus if there one ready. If the host then sends an ACK completing the transaction, the Data transmit transactions send a data packet from the specified endpoint's transmit buffer to the USB bus if there one ready. If the host then sends an ACK completing the transaction, the protocol engine empties the buffer. It also sends a transmit buffer empty interrupt to the control microcontroller to request more data.

4-3-3. Connecting Microcontroller to USB Controller

The ML60851C offers the following configuration options for the microcontroller interface.

- (1) Choice, with ADSEL pin, of separate or multiplexed address and data buses
- (2) Choice, with register setting under program control, of 8- or 16-bit DMA

The 16-bit data bus is only available when 16-bit DMA is used.

The JOB60851 board uses separate address and data buses, an 8-bit data bus, and no DMA.

Figure 4.3.2 shows sample connections to a microcontroller with a 16- or 32-bit bus.

Register must be 8 bits wide. Only DMA uses 16-bit bus. Registers must be aligned at word boundaries for 16-bit bus and at double boundaries for 32-bit bus.

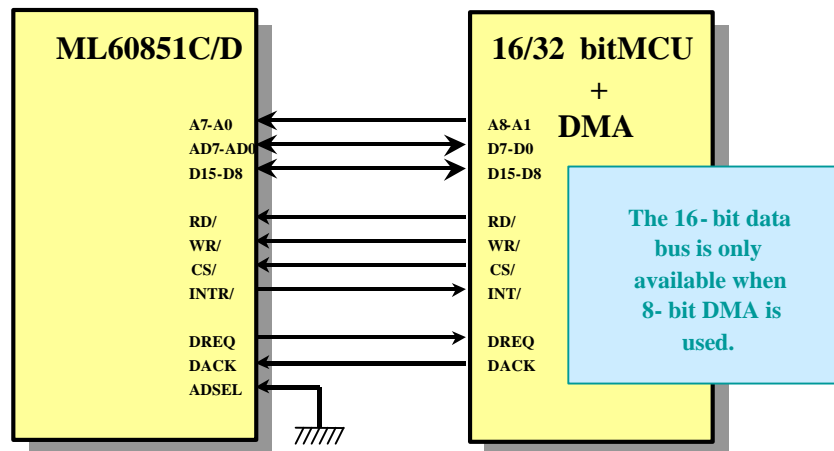

Figure 4.3.2. Microcontroller with 16- or 32-Bit Bus

4-3-4. Special USB Considerations

The following are special points to keep in mind about USB functions.

(1) D+ pull-up resistor

Some systems require software control over the timing with which the USB device connects to the upstream host or hub to provide extra time for initialization and other tasks. The JOB60851 board therefore gives the microcontroller control over the D+ pull-up resistor. For further details, refer to the circuit diagram and the source code for the sample firmware.

(2) Vbus monitor

The JOB60851 board connects the USB power supply (Vbus) line to the microcontroller's analog-to-digital converter. This arrangement makes it possible for the firmware to measure the voltage and thus monitor the connection to an upstream host or hub for disconnected USB cables or removal of power to the host personal computer or intervening hubs. For further details, refer to the circuit diagram.

(3) Bus-powered operation

Moving both the J3 and J15 jumpers from their default 1-2 positions to their 1-3 positions configures the JOB60851 board to take its power from the bus, eliminating the need for the power adapter. We do not recommend using this setting, however, because of the board's development role. The board is able to guarantee neither that power consumption, a function of the program under development, is within the limit reported by the firmware nor that the device under development observes the USB requirement of an average suspend current of 500 μ A for bus-powered devices. In the worst case scenario, a power consumption exceeding the figure reported by the firmware risks damaging the host or intervening hubs.

The ML60851C is, strictly speaking, not a fully compliant bus-powered device. Although it notifies the firmware when it suspends operation in response to a suspend signal from the bus, it also shuts down its clock signal, rendering it unable to detect a subsequent resume signal from the bus. Shutting down the clock signal is, however, the only way to comply

with the above-mentioned requirement for average suspend current.

4-3-5. Building a Product

Generally speaking, building a product with the help of the JOB60851 board requires the following modifications and additions to the software.

(1) Adding and modifying descriptors

At the minimum, the source code has to provide vendor and product IDs. (See Section 4.3.6 below.) Descriptors generally also have to be modified to reflect the final product, application, and device class.

(2) Adding to class specifications

Building a product in a certain class involves adding requests specified by the class specifications and descriptors required by the class. Some classes even require additions and modifications to the standard descriptors.

(3) Adding vendor-specific specifications

Vendor-specific requests implement the control commands and control protocols unique to that vendor. The vendor must also add descriptors that the host can access with GET_DESCRIPTOR requests.

(4) Developing application layer

Here the developer writes an application layer program combining API functions and callback functions.

(5) Tuning data flow

The flexibility of modification that the sample firmware provides through highly generalized programming sometimes comes at the expense of efficiency. Although maximizing system throughput involves looking at more than just firmware, there are places where the source code should be rewritten for speed--to use unidirectional endpoints, for example.

4-3-6. Vendor and Product IDs

Each USB product requires two numbers to uniquely identify it to the host operating system for use in selecting drivers: a VendorID assigned by the USB Implementers Forum and a ProductID chosen by the vendor. The sample firmware uses those for Oki Semiconductor and the JOB60851 Starter Kit, respectively. These may be safely used through the prototype stage. Shipping products, however, must have their own.

The following URL links to the procedure for acquiring a VendorID from the USB Implementers Forum.

<http://www.usb.org/developers/>

4-3-7. Other Tools Necessary

(1) Bus monitor

The sample firmware will not necessarily work perfectly when first ported to a new microcontroller because of the differences in microcontrollers and compilers. An extremely effective way to thoroughly check the operation of such a port is with a bus monitor tracing actual traffic on the bus.

A bus monitor also comes in handy during host driver development when the personal computer hangs, making it impossible to pinpoint the exact circumstances producing the failure.

Bus monitor data is also highly effective in tracing host controller operation and evaluating the final product.

As of August 1999, the following bus monitors are commercially available.

Products:	CATC USB Chief™ Bus & Protocol Analyzers CATC USB Inspector™ Bus & Protocol Analyzer
Developer:	Computer Access Technology Corporation (CATC) http://www.catc.com/
Japanese distributor:	Toyo Technica Co., Ltd. http://www.toyo.co.jp/
Product:	Genoa Technology USB Expert™ Protocol Analyzer
Product:	Genoa Technology, Incorporated. http://www.gentech.com/
Japanese distributor:	Bits Co., Ltd. http://www.bits.co.jp/

(2) Microcontroller emulator

The JOB60851 Starter Kit provides printf(), scanf(), and other C standard I/O library functions for confirmation of operation and simple debugging of programs running on its MSM66Q573 microcontroller. Thorough debugging with program tracing and other facilities for illuminating firmware problems, however, requires an emulator (in-circuit emulator, ROM emulator, etc.) for the target microcontroller. Look for such tools from the microcontroller vendor and third-party sources.

4-3-8. Note on Porting

JOB60851 programming uses a version of the C programming language extended for embedded applications. The following is a list of extension requiring special attention when porting the sample firmware to other microcontrollers and compilers. For further details on these language extension, refer to the compiler manual (Cc665s.pdf) and programming guide (Pg665s.pdf) on the CD-ROM.

(1) #pragma ABSOLUTE variable_name address

This pragma permits specification of the final absolute address for a variable at the C source code level.

(2) #pragma ACAL function_name

This pragma calls the specified function with the more efficient ACAL instruction instead of the normal CAL instruction--provided that the function starts at an address between 1000h and 17ffh. Delete or disable these pragmas when porting the source code to a different microcontroller.

(3) #pragma INTERRUPT function_name vector

This pragma makes the specified function into an interrupt service routine by assigning its entry point to a vector table entry. This microcontroller has separate interrupt vectors for various internal and external interrupts. The sample firmware, however, uses only external interrupts from the USB controller.

(4) #asm and #endasm

These two directives enclose an in-line assembly language block, which the compiler simply passes to the assembler. The sample firmware uses them in read_fifo() and write_fifo(), the functions for reading from and writing to USB controller buffers, and in extint1(), extint4(), and extint5(), the functions for switching register banks in response to an external interrupt from the USB controller.

For further details on this assembly language code, refer to the nX-8/500S Instruction Manual (Nx8_500s.pdf).

(5) __accpass

This modifier changes the function calling sequence to pass one parameter in the accumulator. Note that the compiler's /REG command line option makes this the default for all functions without an overt __noacc modifier.

(6) __noacc

This modifier overrides __accpass and the compiler's /REG command line option to pass all parameters on the stack. This is required for standard library functions, so always include the header files containing the function prototypes. It also applies to the low-level I/O functions read() and write() called by the standard library functions.

Note that incompatible __accpass and __noacc specifications between compile units produces a program that runs out of control.

4-3-9. Limitations

- (1) As of August 1999, sample firmware operation has been confirmed only for the MSM66Q573 plus ML60851C combination. The ARM code is a preliminary version that does not compile.
- (2) The sample firmware has been compiled and tested only with the cc665s compiler only in the small models. Other memory models have not been tested.

4-4. Port 7 LED2 Control

The MSM66Q573 microcontroller on the JOB60851 board has twelve bidirectional ports (P0 to P11) with 75 pins and an input only port (P12).

The Section describes the use of Port 7 (P7), the one connected to LED2.

4-4-1. Port 7 Registers

Each MSM66Q573 microcontroller port on the JOB60851 board has at least three control registers. The following describes those for Port 7.

(1) Port Mode Register (P7IO)

The bits in this register control the I/O directions of the corresponding Port 7 pins: input ("0") or output ("1"). After a reset, this register contains 00H, configuring all pins for input.

Port Mode Register (P7IO)

Bit number	bit7	bit6	bit5	bit4	bit3	bit2	bit1	bit0
P7IO	P7IO7	P7IO6	P7IO5	P7IO4	---	P7IO2	P7IO1	P7IO0
After a reset	0	0	0	0	---	0	0	0

Setting a bit to "0" configures the corresponding Port 7 pin for input; "1" is for output.

(2) Port Secondary Function Control Register (P7SF)

The bits in this register switch between the primary ("0") and secondary ("1") functions of the corresponding Port 7 pins. After a reset, this register contains 00H, configuring all pins for their primary functions.

Port Secondary Function Control Register (P7SF)

Bit number	bit7	bit6	bit5	bit4	bit3	bit2	bit1	bit0	
P7SF	Primary	PWM1 OUT	PWM2 OUT	---	PTM3 OUT	---	---	TXD0	---
	Secondary	P7SF7	P7SF6	P7SF5	P7SF4	---	P7SF2	P7SF1	P7SF0
After a reset	0	0	0	0	---	0	0	0	

Setting a bit to "0" configures the corresponding Port 7 pin for its primary function; "1" is for its secondary function.

Note that bit 0 has no secondary function because the corresponding pin is always a serial port receive data pin. To enable this input pin, simply write "0" to bit 0 in the Port Mode Register (P7IO).

(3) Data Port Register (P7)

The bits in this register hold the port's I/O data. After a reset, this register contains 00H.

Reading this register yields the input states of pins configured for input and the last data written for pins configured for output.

Writing to this register overwrites all bits regardless of pin I/O directions.

This concludes the description of Port 7. To use the port, manipulate the above registers within the program. For further details on registers for other ports and Port 7 operation, refer to Chapter 5 in the MSM6657 Family User's Manual.

4-4-2. Changing LED2 Color

The next page gives sample code (port7exp.c) that changes the color of the LED connected to Port 7.

This sample program calls std_init_573(), a support function for initializing the MSM66Q573 on the JOB60851 board, so be sure to include the corresponding source code file (stdrw573.c) on the compiler command line.

```
CL665S /T m66573 /H /WIN port7exp.c stdrw573.c l66ks50s.lib <Enter>
```

This sample program uses the secondary function, serial port, for Port 7's lowest four bits to send character strings to the terminal emulator running on the host personal computer by setting the lower halves of Port Mode (P7IO) and Port Secondary Function Control (P7SF) Registers to the following values.

```
P7IO = 0xC2;    /* 1100_-010 */ /* Configure Port 7 pin 1 for output */  
P7SF = 0x03;    /* 0000_-011 */ /* Configure Port 7 pins 1 and 0 for secondary function */
```

See Section 4.5 "Standard I/O over Serial Link" below for a different approach.

Sample Port 7 Control Program

```
/* Sample program(Port7) */
/* Filename:port7exp.c */
/* Copyright(C) 1999 TECHNOCOLLAGE,Inc. All rights reserved. */

#include<stdio.h>
#include<stdlib.h>
#include<m66573.h>

void main(void)
{
    int i = 0;
    unsigned int j = 0;

    std_init_573(); /* Initialize MSM66Q573 and the port */

    P7 = 0x00;      /* 0000_-000 */ /* Clear output data. 00B = orange */

    P7IO = 0xC2;    /* 1100_-010 */ /* Configure Port 7 pin 1 for output */
    P7SF = 0x03;    /* 0000_-011 */ /* Configure Port 7 pins 1 and 0 for secondary function
    */

    S0BUF = 0x0A;
    printf_c(" LED should now be orange \n");

    /* Time waster (sleep) */
    for(i=0;i<10;i++)
    {
        for(j=0;j<65535;j++);
    }

    printf_c(" LED should now be green \n");
    P7_7 = 0;      /* 01B = green */
    P7_6 = 1;

    /* Time waster (sleep) */
        for(i=0;i<10;i++)
    {
        for(j=0;j<65535;j++);
    }

    printf_c(" LED should now be red \n");
    P7_7 = 1;
    P7_6 = 0;      /* 10B = red */

}
```

4-5. Standard I/O over Serial Link

Section 2-.3 "Running User Programs" downloaded and executed a simple "Hello world!" program that displays its message on the personal computer screen.

C compilers for personal computers assign a keyboard to the standard input and a monitor to the standard output. The JOB60851 board has neither, but the programmer can provide substitutes as described in this section.

4-5-1. JOB60851 Board Standard I/O

The sample file `stdrw573.c` maps the JOB60851 board's standard input and output to a serial link joining a terminal emulator running on the host personal computer to an MSM66Q573 serial port on the JOB60851 board.

Standard input: Data from terminal emulator to MSM66Q573 RX pin

Standard output: Data to terminal emulator from MSM66Q573 TX pin

The functions required to create these mappings are `read()` and `write()`. Because of their tight links with hardware, these are known as low-level functions (as opposed to high-level functions without such dependencies).

Figure 4.5.1 summarizes the data flows for the resulting I/O.

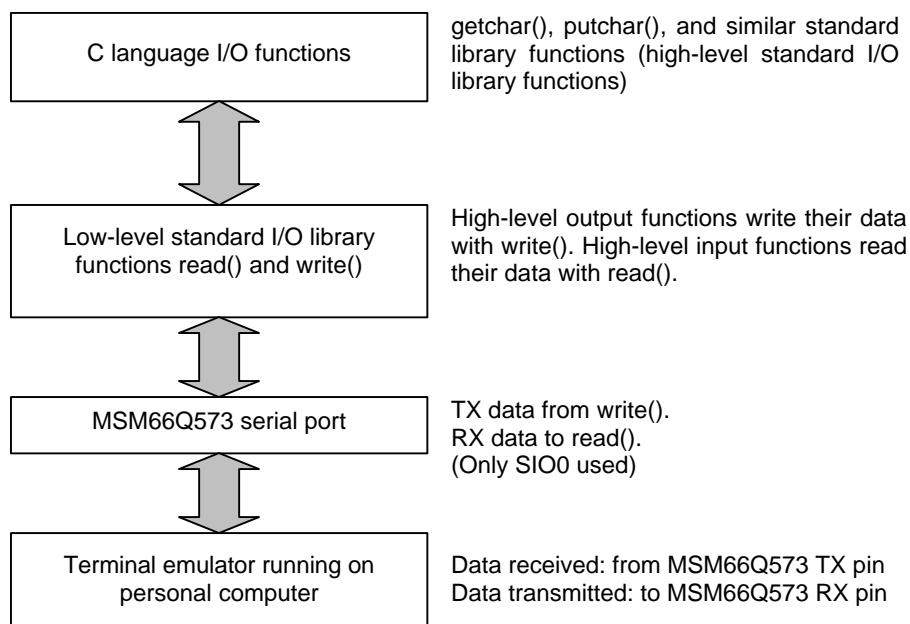

Figure 4.5.1. JOB60851 Board Standard I/O

Table 4.5.1 shows the dependencies on these two low-level functions by the higher-level I/O functions included in the standard libraries for the JOB60851 board C compiler (`cc665s`). Because of these dependencies, be sure to include the corresponding source code file (`stdrw573.c`) on the compiler command line.

Table 4.5.1. Library Functions Calling read() and write()

I/O Library Function	Required Low-Level Function
fgetc,fgets,fscanf,getc,getchar,gets,scanf	read
fflush,fprintf,fputc,fputs,fwrite,printf,putc,putchar,puts,vfprintf,vprintf	write

For further details on these and other library functions, refer to the RTL665S Run-Time Library Reference.

The source code file `stdrw573.c` contains the source code and settings for these two low-level functions. Including it on the compiler command line provides the user program with access to the standard library I/O functions.

Command Line

```
c1665s /T m66573 /H /WIN [user program] stdrw573.c l66ks50s.lib <enter>
```

4.5.2 Serial Port

Including the source code file `stdrw573.c` provides the user program with access to this standard I/O. This Section discusses the MSM66Q573 internal serial port that the JOB60851 board uses for this purpose, with the structure outlined in Figure 4.5.2.

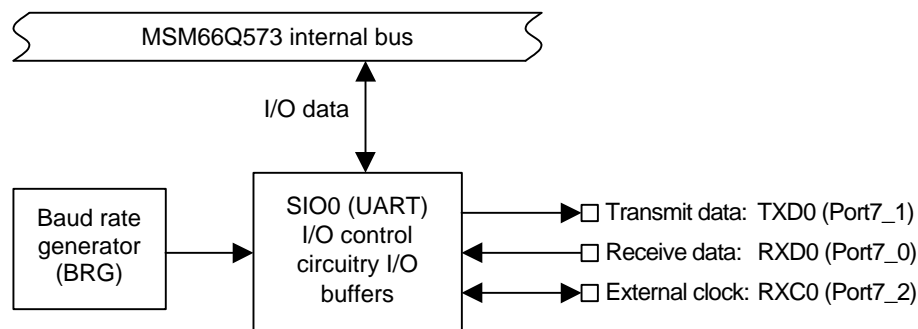

Figure 4.5.2. Serial Port Structure

Port 7_1 on the is the MSM66Q573 TX pin transmitting the standard output data to the terminal emulator running on the host personal computer; Port 7_0, the RX pin receiving the standard input data in the reverse direction. (The JOB60851 board does not use Port 7_2.)

The baud rate generator (BRG) uses the overflow signal from MSM66Q573 internal timer 3.

For further details on these components, refer to the MSM6657 Family User's Manual.

Serial port (SIO0): Chapter 12

Internal timer: Chapter 8, page 9 and following

The source code file `stdrw573.c` sets up the serial port for these functions using the following steps between the start and end comments for port and timer setup.

(1) Configure timer 3 for use as baud rate generator (BRG)

The serial port used for standard I/O derives its baud rate from the MSM66Q573 internal timer 3 overflow signal. The source code file `stdrw573.c` contains the settings for producing a 38,400-b/s baud rate from the JOB60851 board's 24-MHz system clock.

(2) Configure serial port

All serial ports have registers for controlling operation. SIO0 has four such registers.

(a) SIO0 Transmit Control Register

This register specifies the data format for transmitting data and enables or disables the relevant interrupts. The source code file `stdrw573.c` uses the following settings.

Word size	8 bits
Stop bits	2
Parity check	None
Transmit buffer empty interrupt	Enabled
Transmission end interrupt	Enabled

(b) SIO0 Receive Control Register

This register specifies the data format for receiving and enables or disables the relevant interrupts. The source code file `stdrw573.c` uses the following settings.

Word size	8 bits
Baud rate clock	Timer 3
Parity check	None
Receive end interrupt	Enabled
SIO0 receive	Enabled

(c) SIO0 Receive/Transmit Buffer Register

This 8-bit register holds the transfer data. It is actually two separate registers differentiated by access. Writing to it writes to the transmit buffer. Reading from it reads from the receive buffer.

(d) SIO0 Status Register

This status register gives the error status at the end of transmit/receive operations and the running status during such operations. Note that the hardware does not reset this register, so the user application program must do so before using the serial port.

Framing error flag	"0"
Overrun error flag	"0"
Parity error flag	"0"
Transmit buffer empty flag	"0"
Transmit end interrupt flag	"0"

Receive end interrupt flag "0"

(3) Configuring TX and RX pins

These pins represent secondary functions for Port 7 pins 1 and 0, respectively, so write the following values to the corresponding bits in the Port Mode (P7IO) and Port Secondary Function Control (P7SF) Registers.

Port Mode (P7IO): "1" (output) for P7_1 and "0" (input) for P7_0

Port Secondary Function Control (P7SF): "1" (secondary) for both P7_1 and P7_0

This completes the serial port setup procedure.

4-5-3. read() and write() Functions

For full particulars on these two functions, refer to the comments in the source code file `stdrw573.c`. This section gives just broad outlines.

(1) read() function

Figure 4.5.3 gives a flowchart for function operation.

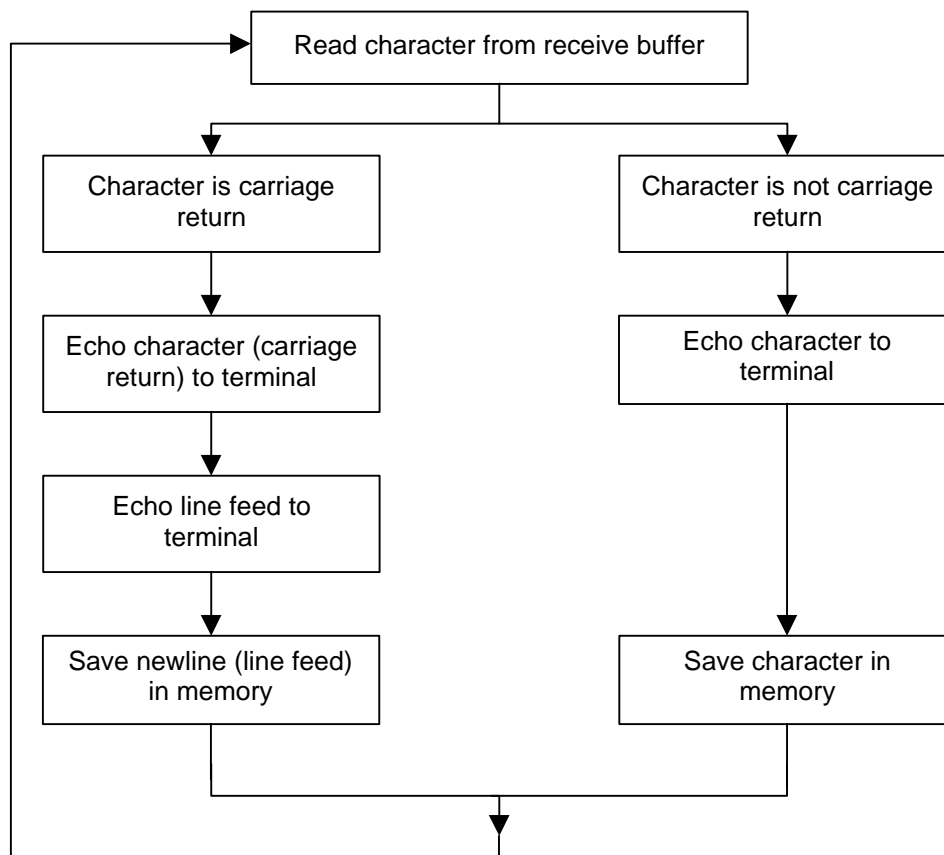

Figure 4.5.3. read() Operation

The function reads the character in the single-byte receive buffer.

If that character is not a carriage return, the function echoes it back to the terminal emulator and stores it as is in memory (as specified by the user application program), incrementing a buffer

pointer as necessary for string input.

If the character is a carriage return, the function echoes both it and a line feed back to the terminal emulator and stores the latter in memory instead.

The function repeats the above cycle the number of times specified by the count argument to the read() function. The compiler automatically determines this count from the standard I/O library function calling read().

The echo portions of the function are there to provide visual feedback when testing the firmware from the personal computer keyboard. If the user application program does not need this feedback, echoing can be dropped.

(2) write() function

Figure 4.5.4 gives a flowchart for function operation.

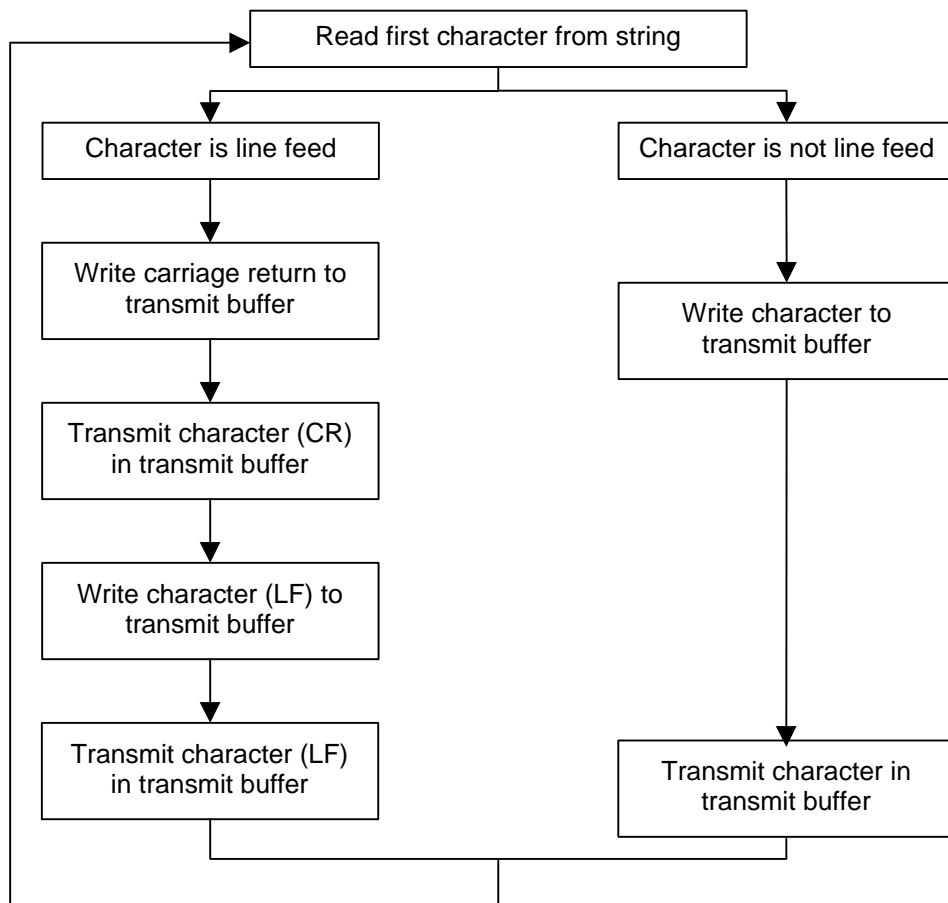

Figure 4.5.4. write() Operation

The control flow is slightly more complicated than that for read(), but the entire operation can be described in a single sentence: The function reads a character from the buffer and transmits it, inserting a carriage return into the output stream before a line feed.

The function repeats the above cycle the number of times specified by the count argument to the write() function. The compiler automatically determines this count from the standard I/O library function calling write().

4-5-4. Standard I/O Examples

This Section presents examples actually using this standard I/O.

For further details on the printf_c(), puts(), and gets() library functions used, refer to the RTL665S Run-Time Library Reference.

(1) Using standard output and write()

Section 2-3. "Running User Programs" gives one example of a program that writes to standard output. The following is another.

For further details on the printf_c() and puts() library functions used, refer to the RTL665S Run-Time Library Reference.

Sample Program Using Standard Output

```
/* Read/Write sample program 1 */
/* Filename:rw_smp11.c          */
/* Copyright(C) 1999 TECHNOCOLLAGE,Inc. All right reserved. */

#include<stdio.h>
#include<stdlib.h>
#include<m66573.h>

void main(void)
{
    int day;
    char *d_name[] = {
        "Sunday    : Sunday",
        "Monday    : Monday",
        "Tuesday   : Tuesday",
        "Wednesday : Wednesday",
        "Thursday  : Thursday",
        "Friday    : Friday",
        "Saturday  : Saturday"};
    /* Initialize MSM66Q573 */
    std_init_573();
    S0BUF = 0x0A;

    /* Main display loop */
    for(day=0;day<7;day++)
    {
        puts(d_name[day]);    /* Send string to standard output */
    }
}
```

(2) Using standard input and read()

The following source codes is an example of a program that reads from standard input.

For further details on the printf_c() and gets() library functions used, refer to the RTL665S Run-Time Library Reference.

Sample Program Using Standard Input

```
/* Read/Write sample program 2 */
/* Filename:rw_smp12.c          */
/* Copyright(C) 1999 Oki Electric Industry Co.,Ltd. all right reserved. */
/* Copyright(C) 1999 TECHNOCOLLAGE,Inc. all right reserved. */

#include<stdio.h>
#include<stdlib.h>
#include<m66573.h>

void main(void){

    char buf[80];

    std_init_573();
    S0BUF = 0x0A;

    /* Send string to standard output */
    printf_c("Please input words!\n");

    /* Send string to standard output */
    gets(buf);

    /* Echo input to standard output */
    printf_c("Your input words = %s\n",buf);

}
```

4-5-5. Debugging with Standard I/O

One way to debug programs for the JOB60851 board is with printf() calls. The sample program in Section 4-4-2. "Changing LED2 Color," for example, used them to document program steps. These calls can also track changes in key variables. These progress messages then become your guide to program flow and beha